

ELEMENTARY MACHINE SHOP PRACTICE

A TEXT BOOK PRESENTING THE
ELEMENTS OF THE MACHINISTS' TRADE

BY

JAMES A. PRATT, MECH. E. 873'

DIRECTOR WILLIAMSON FREE SCHOOL OF MECHANICAL TRADES,
MEMBER AM. SOC. M.E., FORMERLY DISTRICT EDUCATIONAL
DIRECTOR, COM. ON EDUCATION AND SPECIAL
TRAINING U. S. WAR DEPT.

205 ILLUSTRATIONS



NEW YORK
D. VAN NOSTRAND COMPANY
EIGHT WARREN STREET
1921

COPYRIGHT, 1921, BY
D. VAN NOSTRAND COMPANY

PREFACE

ELEMENTARY MACHINE SHOP PRACTICE is offered as a text, presenting the fundamentals of the machinist's trade. The extended detail of the large machine shop is based on a certain number of elementary principles which are applied to the doing of bench work, and to the operation of machine tools.

Not all of these elementary principles are introduced in the present volume, as this work has been devoted to the trade fundamentals. It is better for the beginner in machine work, to gain a thorough mastery of a few first principles, and on this foundation build his knowledge, than to study a multiplicity of detail without considering the relation of this detail to constructive trade principles.

The processes described are related to the bench, lathe drill press, shaper, slotter, grinder, miller and planer.

The author feels that the study of the machines mentioned, gives a satisfactory understanding of the fundamental processes involved in the metal working industries of the present day. It is hoped that this text may prove of value to apprentices, students, workmen and teachers.

J. A. P.

WILLIAMSON SCHOOL.

374023

CONTENTS

CHAPTER	PAGE
I. THE BENCH AND BENCH WORK	1
II. SUPPLIES AND MISCELLANEOUS TOOLS	27
III. HARDENING AND TEMPERING. MACHINE ADJUSTMENTS. EQUIPMENT. GENERAL TOOLS	60
IV. LATHE TOOLS	90
V. THE LATHE BACKREST. FOLLOW REST. COMPOUND REST. ECCENTRIC TURNING	135
VI. THE DRILLER OR DRILL PRESS	147
VII. THE SHAPER	157
VIII. THE SLOTTER	173
IX. THE GRINDER	181
X. GRINDING (Continued)	198
XI. THE MILLING MACHINE OR MILLER	206
XII. GEARING	220
XIII. THE PLANER	234
XIV. MACHINE SHOP CALCULATIONS	252
XV. MACHINE GLOSSARY	273
TABLES	283
BIBLIOGRAPHY	301
COURSE OUTLINE	304
INDEX	313

MACHINE SHOP PRACTICE

CHAPTER I

THE BENCH AND BENCH WORK

THE learner should constantly refer to the glossary, page 273 while studying this text, in order that he may fix in his mind the more common machine shop terms. It is important that a boy or young man, starting to learn a trade, shall have a clearly defined idea of the requirements of that trade. Since in this book, we intend to study the machinist's trade, we may properly ask; What is a machinist?

First, a machinist is a man who can build machinery; in the building of this machinery, he must operate other machinery. He must be able to make and read a mechanical drawing, so that he can carry out and give orders. As he progresses in the work it will be necessary for him to give instructions to other people, relative to methods of doing work. He must be acquainted with the various kinds of material which are used by the machinist in carrying out his work; furthermore, he should know the proper proportions of the various shop accessories, such as benches, tool racks, lathe boards and similar small equipment. He should be capable of making up requisitions for the different classes of small supplies which he needs in the shop in order to carry on his work. Such a list includes machine screws, wood screws, nails, files, drills, emery cloth, sand paper, emery, waste, oil, etc.

2 PRACTICAL MACHINE SHOP PRACTICE

Having now some idea of the requirements of a machinist, so far as his general knowledge is concerned, we will study some of the equipment which he uses in the shop.

First, the bench at which the machinist works. The beginner in the machine shop most commonly starts his

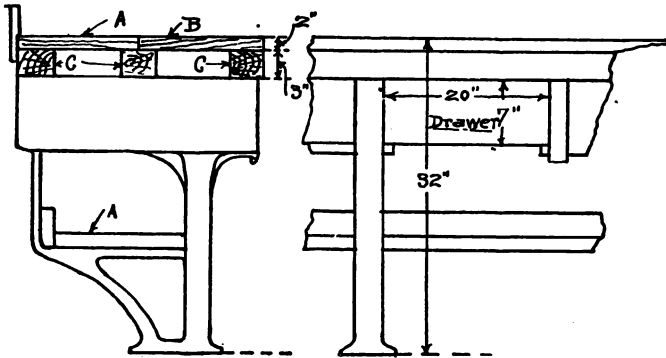

Fig. 1

Parts marked *A* made of hemlock, poplar or white pine.
Parts marked *B* made of oak or other well seasoned hard wood.
Parts marked *C* made of yellow pine or oak.
Other parts are of cast iron.

work at the bench, because when entering the shop, surrounded by a great many complicated machines, he is naturally more or less nervous.

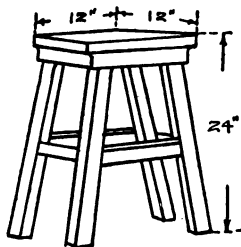

Fig. 2

If he were put directly on a machine, he would make mistakes which would not be made later, after becoming used to shop surroundings. Figure 1 shows a section of a machinist's bench which is very serviceable. It is of such a height that the average workman can stand or sit comfortably for an extended period of time. A serviceable type of stool is shown in Fig. 2.

In the building of the machinist's bench, the heavy front plank is made of hard wood — ash, oak, or maple being satisfactory; it should be about two inches thick. The backing boards may be of hemlock, spruce, or yellow pine, while the base may be of cast iron or wood. The general dimensions presented should not be departed from to any marked degree. The machinist uses his

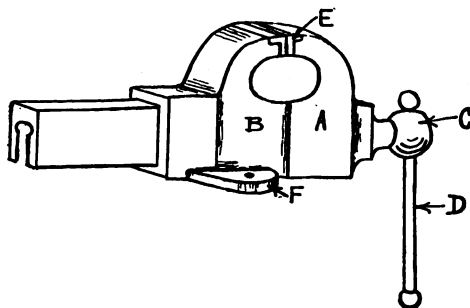

Fig. 3

- | | |
|-----------------------|-----------------|
| A. Sliding jaw. | D. Vise handle. |
| B. Solid or fast jaw. | E. Jaw face. |
| C. Vise screw. | F. Bench lugs. |

bench for finishing small parts, for assembling machinery, and for laying out his work.

In doing much of this work, it is necessary for the workman to use a bench vise. In this device he holds his work when chipping, filing, fitting, or finishing. Figure 3 gives an idea of the appearance of a machinist's vise, while in Fig. 4 are shown some of the accessories used, when holding material in the vise. Note that in the illustration of the vise, the various parts are named.

In Fig. 3 at A is shown a pair of copper jaws. These are placed in the main jaws of the vise, when holding work which might be damaged by clamping directly between the unprotected steel jaws. Copper jaws should always be used when holding any finished work in the

4 PRACTICAL MACHINE SHOP PRACTICE

vise. At *B* is shown a pair of leather faces, which are used for the same purpose as the copper jaws, but on work which is more highly finished. Thus a workman should never hold, by either steel or copper jaws, a highly polished piece, or a piece which has been scraped to a bearing. If it is necessary to place such a piece of work

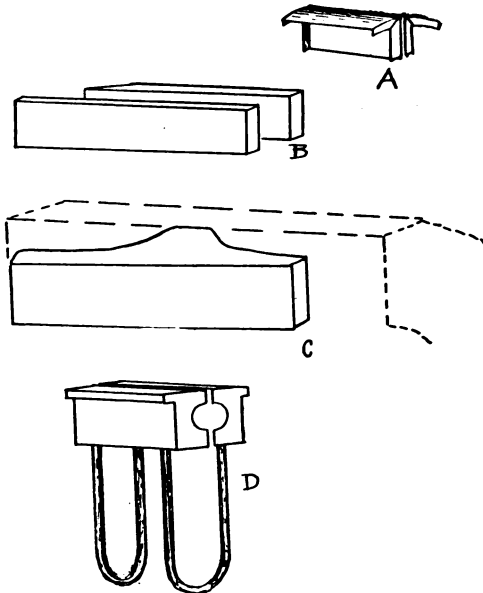

Fig. 4

in the vise, the finished surfaces coming against the vise jaw should be protected by the use of leather faces.

At *C* is shown a taper slip jaw, which is used for holding taper or wedge pieces in the vise. At *D* is shown a pair of pin slip jaws, which are used for holding cylindrical pieces in the vise.

In connection with the first work at the bench, the beginner usually finds it necessary to use a hammer and

a cold chisel, so we will at this time study these two very important though simple tools. A good hammer for general use should weigh about one pound, be of the ball peen type, and be fitted with a 16 inch handle. The cold chisel is made of what is known as tool steel.

Later on we will study tool steel with considerable care, but for the present we may say that it is a kind of steel which permits being made sufficiently hard to cut other metals. The treatment which makes the steel hard, is called hardening, and consists of heating the tool to a red heat, then suddenly dipping it in water. In order to be serviceable, however, the tool must be tempered, which process is effected by placing it in the fire, and carefully heating it, until a desired color is obtained on the face of the tool. The face is slightly polished after hardening, so that the temper color may be seen. The details of this process of hardening and tempering are described in a later chapter.

Now although we have two very simple tools, there is considerable manual ability required to use them properly. First, there is the worker's position at the bench, then the way in which he holds the chisel and the hammer. By adopting the correct position, one is enabled to work for an extended period of time, without undue fatigue. The chisel should be held loosely in the left hand, assuming that the learner is right-handed, using the full hand with which to hold the tool about midway between the head and the shank. As a new chisel is approximately 7 inches long, the space from the head of the chisel to the hand is about $1\frac{1}{2}$ inches.

The hammer should be held well out towards the end of the handle, and the workman should stand so that the front of his body is perpendicular to the center line of the vise, and slightly to the left of it, so that by a free

6 PRACTICAL MACHINE SHOP PRACTICE

swing of the hammer over the shoulder, he strikes the chisel squarely and evenly without undue effort.

Now in the process of chipping down a surface, the workman will meet with much better success if he does not use the broad cold chisel for his first cuts, but uses a narrower chisel, such as is shown in Fig. 5 at *B*, known

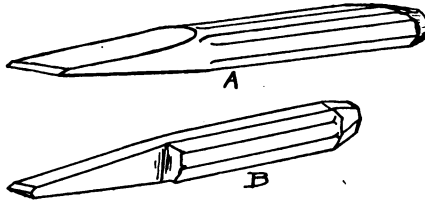

Fig. 5

A. Cold chisel. B. Cape chisel.

in the trade as a cape chisel. This chisel is first used to cut scores in the surface of the piece, the center lines of which are about one inch apart. After these scores are cut through, the piece will have a surface appearance

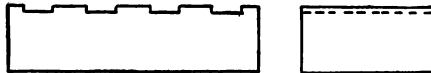

Fig. 6

similar to that shown in Fig. 6, a series of ridges having appeared, due to cutting down with the cape chisel.

The cold chisel may now be used to cut these ridges away and to leave a plane or flat surface. This is now said to be roughed out, and is ready for the finishing process, which consists of bringing the surface to the required condition by means of a file. This will introduce us a number of new tools.

First, there is the file, of which we have a great variety, and then there is a tool which is used for cleaning the

file. We must also have a simple means of quickly testing the surface while we are working on it.

The tool used for cleaning the file is known as a file card, and is shown in Fig. 7, while the tool used for testing the surface is known as a straight edge. Ordinarily the machinist, when working on such pieces as we are discussing, uses as a straight edge one of his scales or steel measuring rules.

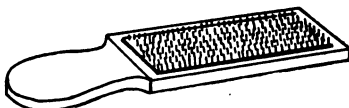

Fig. 7

Let us now return to the file. First look at Fig. 8, which presents an illustration of a file blank. This is the piece of steel which is cut to make the file that is used by the workman in the machine shop. Notice particularly the names of the parts. In ordering a file, one must state the shape, kind of cut, and length which is

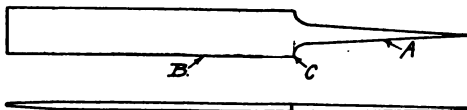

Fig. 8

A is the tang.

B is the body.

C is the shoulder.

The length of the body is the dimension used in specifying the length of the file.

wanted. Now as to shapes, we have what are known as hands, flats, rounds, squares, pillars, triangular, and slotting. While the toolmaker uses a great many other shapes, those mentioned above cover the general requirements of the trade. As to lengths, the hand and flat files may be obtained from 6 to 14 inches, while the square, round, triangular, and most of the others can be obtained in lengths from 4 to 12 inches.

The young worker interested in his trade will do well to write to the Nicholson File Co., Providence, R. I., for

their small catalogue and their booklet entitled, "File Philosophy." Both of these books contain a great deal of practical information bearing on the subject of files.

The following cuts are commonly furnished in the trade — rough, coarse, bastard, second cut, smooth, and dead smooth files. The bastard, second cut, smooth, and dead smooth are the files most commonly used by the machinist. In working with a file, it is necessary to have it properly handled. Handles are commonly supplied of both hard and soft wood in various sizes. The

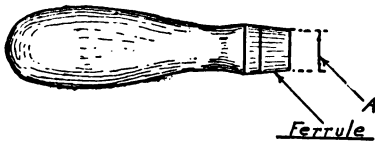

Fig. 9

Available standard sizes measured at A are $\frac{1}{2}$ ", $\frac{3}{4}$ ", 1 ", $1\frac{1}{4}$ ", $1\frac{1}{2}$ ", $1\frac{3}{4}$ ", 2 ", $2\frac{1}{4}$ ". Handles can be obtained in both hard and soft wood. The soft wood handles are the cheaper in price.

length from the end. The file should then be wrapped with waste at the shoulder, dipped in water, and the tang heated red hot. Then force the file into the handle until it is about $\frac{1}{2}$ " or $\frac{3}{4}$ " from the shoulder of the file. The file should now be quickly withdrawn and cooled. It may then be solidly driven into the handle, by striking it on the bench.

We are now ready to start using this tool which we have been studying. For finishing ordinary work we may use a twelve inch flat bastard file. A correct position when filing at the vise is shown in Fig. 10. The end of the handle should butt against the palm of the right hand, with the thumb resting along the top of the file, and the handle grasped firmly but not too tightly. The palm of the left hand should rest on the end of the

table in connection with Fig. 9, gives necessary information for ordering file handles.

When placing a handle on the file, it should first be drilled with a hole about the size of the tang at a point one third the

file, with the elbow thrown rather high in the air, so that considerable pressure may be applied when making the cutting stroke. The stroke should not be straight across the work, but should be in a diagonal direction, so that the file takes a shearing cut.

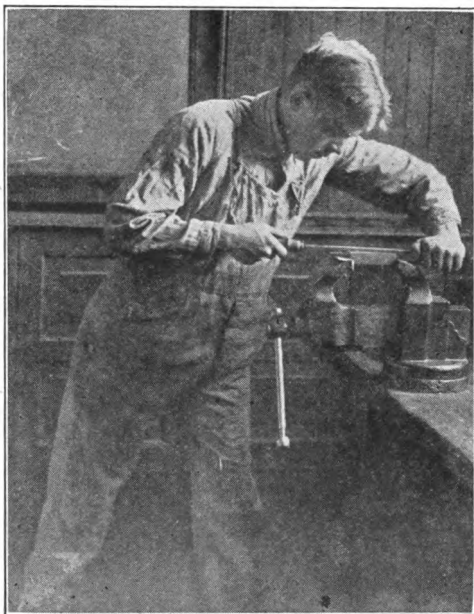

Fig. 10

After the surface has been reduced in a measure, the straight edge should be laid along it, to see whether or not the surface is coming true or flat. Considerable practice will be required to enable the worker to produce a flat surface by means of filing, and practice is the only thing which will give him the mastery of this art.

! **Scraping.** — For very accurate work the fitting of machine parts must be done by scraping. Chipping and

10 PRACTICAL MACHINE SHOP PRACTICE

filing have been taken up and we may properly study scraping at this time. For finishing flat surfaces accu-

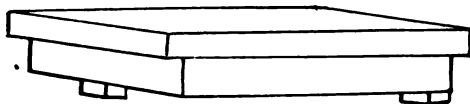

Fig. 11

rately the workman must use a surface plate, such as is illustrated in Fig. 11; these plates are made and sold in the market by machine tool manufacturers.

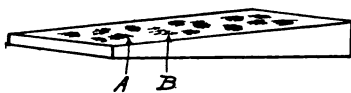

Fig. 12

The job which we will use to illustrate the process of scraping is shown in Fig. 12; it is a cross head shoe for an engine and is accurately planed and chipped or filed before we start

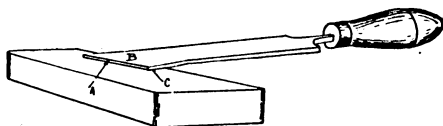

Fig. 13

scraping. The scraper we use is shown in Fig. 13; it can be made from an old flat file, forged at the end; it must be hardened and tempered, ground on end *A* and the two faces *B* and *C*. This grinding is done on the emery wheel or grindstone, after which the scraper must be carefully stoned on the oil stone. When stoning, the stone must be kept wet with kerosene; stone the faces first, as shown in Fig. 13 then stone the end as illustrated in Fig. 14.

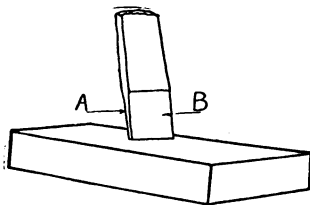

Fig. 14

Do not hold the scraper perfectly straight when stoning, nor at a right angle to the side of the stone, but tip it slightly from the vertical and hold the face at an acute angle to the side of the stone, as illustrated in Fig. 14. Move the scraper somewhat rapidly over the face of the stone, keeping side *A* of the scraper away from you; when the edge at face *A* has been sharpened, turn the scraper around, and stone face *B* in the same manner.

Rock the scraper slightly right and left, as it is moved to and fro, thus producing an end, such as is shown enlarged in Fig. 15. If the stoning is properly done the tool will cut freely, without chatter.



Fig. 15

Having the scraper properly sharpened, we now place the work in the vise, using copper jaws, and avoiding clamping too tightly so that the piece is buckled, or "sprung" as the machinist would say. In working down the surface do not move the scraper constantly in one direction, but scrape a spot as at *A* Fig. 12 in one direction as indicated by the arrows, then a spot as at *B* in a different direction, and so on over the whole surface. This constant change of direction rapidly reduces irregularities and develops a plane surface; the whole surface should be gone over in the manner described in order to remove the heaviest tool marks. This process is known as spotting.

Take a small amount of red lead, and moisten it with machine or lard oil, so it forms a putty; rub the fingers over the putty, and then over the surface plate, applying considerable pressure. You will notice that rubbing the putty on the surface plate in this manner will make it look dull. The whole surface of the plate should be covered with red lead as described. Use only just enough putty to dull the surface of the plate; no putty should

show on the plate after making the application described.

- Remove the work from the vise, wipe all dirt and filings from its surface, using the bare hand. Carefully lay the work on the surface plate, and applying pressure from the top, move the work slowly about. Now remove the work from the surface plate, and upon inspection, a number of dark spots will be seen on the surface of the work, as shown at Fig. 12.

Take the scraper and remove these spots, bearing rather heavily on the scraper, so it will cut freely; then repeat the operation described. The process of rubbing

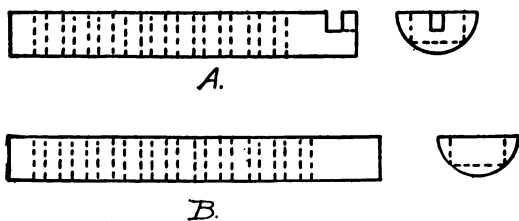

Fig. 16

A is the valve.

B is the seat.

and scraping is continued until the dark spots show all over the work, when it is said to have been scraped to a bearing.

This shoe which has been thus finished is now placed on the engine guide, and the guide is scraped to the shoe, using the shoe as a surface plate. On many jobs it is not necessary to use a surface plate, to scrape the piece, though it is best to do so if possible. As an example we may take the job illustrated in Fig. 16, which shows an exhaust valve and seat for a steam engine. In this case, after both parts have been planed and spotted, some red lead putty is rubbed on the seat face, and valve face is laid against it; the valve is now moved back and forth on the seat for about one minute. When the valve is

lifted off the seat, we will find that the movement has produced dark spots on the valve, and light spots on the seat. The workman scrapes these spots on both members, cleans surfaces with his hand, puts a little more red lead putty on the seat and repeats the operation, until spots show all over the surface of both pieces.

In scraping, always keep the scraper sharp, and have enough red lead on the surface plate, or parts, to show bearing spots clearly, but not enough of it to rub over surface being scraped. The process

just described is called surface scraping. In Fig. 17 we see an illustration of one half of a bearing box which is to be scraped to fit a shaft. This work is known as cylindrical scraping; in a general way the work is not different from surface scraping, though the scraper used

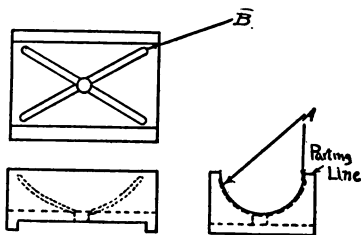

Fig. 17

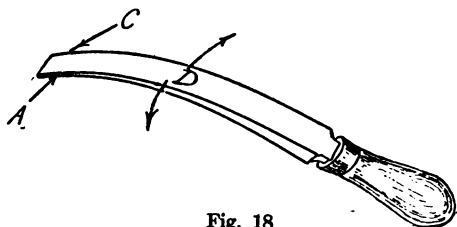

Fig. 18

C and *A* are the cutting edges on this scraper. The tool is moved in the direction of the arrows at *D*, when cutting.

is not of the same form. This scraper is made from a worn half round file, as a rule. Bearing scrapers can also be purchased at hardware stores, in the large industrial centers. In making the scraper from a file, the teeth are ground off, and the file is bent as shown in Fig. 18.

This form enables us to work on the inner surface of a cylindrical form at any desired point. The scraper must be hardened, tempered, ground and stoned on surfaces *A*, *D* and *C*.

In scraping the bearing the process is as follows: the shaft having been smoothly turned or ground, spot the bearing surface down, rub red lead putty on the shaft, put the box in place on the shaft, roll it back and forth a few times, moving it slightly endwise as it is rolled over the shaft. Remove the box, and scrape the spots with the curved scraper, shown in the figure. Scrape the box only; no work is done on the shaft, as this is finished in the machine. After scraping, wipe the surface of the box with the hand, rub red lead on the shaft, and repeat the operation described, until we have a bearing over the whole surface.

A cylindrical box should be slightly relieved at the sides as indicated at *A*, Fig. 17. This relieving is done by scraping the surface away so there is no bearing at the areas indicated for about $\frac{1}{2}$ " or $\frac{3}{4}$ " from the parting line of the box. This treatment of the bearing assures a free running box. The side relief just described is not necessary on boxes fitted to slow running shafts. A bearing must be fitted in such a way that it may be properly lubricated and at *B*, Fig. 17, we see the manner in which the workman finishes the oil hole and bearing surface for a proper distribution of oil. Grooves are cut away from the oil hole to the corners of the box with a small round edge chisel, and filed with a small round file. Grooves should not be cut to the edge of the box, but should stop a half or three quarters of an inch inside the edge, as indicated by the illustration.

Having learned, now, how to produce a plane surface, we may begin to discuss the finished dimensions of our work. Castings come to the machine shop somewhat

larger than they are to be when completed, in order that the machinist may be enabled to finish them properly. Since the machinist must work to dimension, he must have a knowledge of measurement.

The modern measuring system has been a process of gradual evolution from very crude beginnings. The measuring unit in ancient times consisted of some portion of a ruler's body, which was regarded as a basis of measurement for the land over which he ruled. There were two unfortunate conditions connected with such a system, if it was to be used extensively in constructive or manufacturing work. First, every realm, whether large or small, had a different unit of measurement; and secondly, when a ruler died or was deposed, the measuring system of his realm became useless, and complete revision was necessary. As people advanced in education, they began to look about for a more logical unit, and at the present time our measuring system is based on a certain proportion of the earth's circumference, which is called a meter. Two systems of measurement are in use at the present time among manufacturing nations. One is known as the Metric System, and the other is known as the English System.

Since the English speaking people use the English System, we will discuss this first. The unit of measure in this system is known as the yard. It is very nearly equal in length to the meter, and for manufacturing and constructive purposes is divided into smaller units, known as feet, inches, and fractions of inches. Larger units than the yard are also used in this system, in order to express the larger linear measurements. The following table presents the English System:

12 inches = 1 foot	$5\frac{1}{2}$ yards = 1 rod
3 feet = 1 yard	320 rods = 1 mile

We have already stated that the inch is further subdivided in order that the machinist may conveniently handle the minute dimensions demanded in his work; this subdivision is quite extended, reaching the very small unit of $\frac{1}{10,000}$ of an inch. There are several methods of subdividing the inch for use in the machine shop. First, there is the common graduated scale, shown in Fig. 19; second, the improved or binary graduated

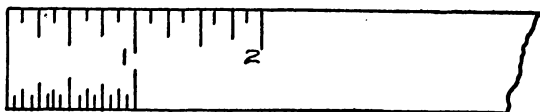

Fig. 19

scale; third, the micrometer caliper; fourth, the vernier caliper; and fifth, the standard gage.

In Fig. 19 is shown an illustration of the ordinary scale or steel rule, which is used by the machinist in his daily work. The one most commonly called for is 6 inches in length, and is graduated or marked along the edges in eighths, sixteenths, thirty-seconds, and sixty-fourths of an inch. Scales of a similar kind are available in 12-inch lengths also, but the 6-inch length usually meets all the requirements of the apprentice machinist. The kind of graduation which is found on a scale is designated by a number; the series of numbers covering the various graduations is found in table 1. With the commonly used scale it is not possible to get a finer division of an inch than $\frac{1}{64}$, hence an improvement on this scale was brought out, such as is shown in Fig. 20.

The improvement consists of placing at the end of the scale a series of small graduations, nine in number. The edge of the scale on which these graduations are placed is graduated in hundredths of an inch; the smaller graduations at the end, to which reference has been made, are

eleven thousandths of an inch apart. Beyond these small graduations is placed a series of dots, eight in number, the one nearest the edge of the rule being placed $\frac{1}{1000}$ of an inch from the nearest graduation; the second dot $\frac{2}{1000}$ and so on; these dots are continued in a line across the scale, each $\frac{1}{1000}$ of an inch farther from the last line of the graduations, than the one formerly placed. The arrangement is shown enlarged in Fig. 20. By the use in combination of the various graduations and the dots, any measurement up to the full length of the rule may

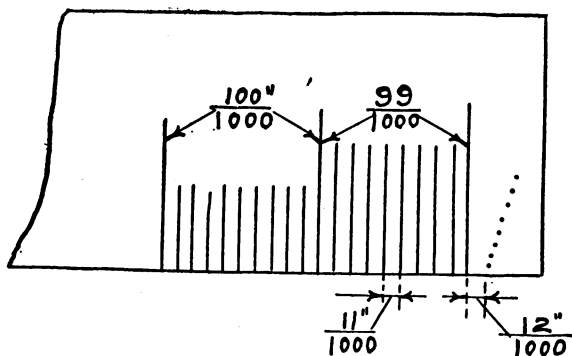

Fig. 20

be obtained by the inch, hundredths, and thousandths of an inch. Let us study this method of linear measure division in some detail; looking at Fig. 20 we see enlarged, the special graduations at the end section of the scale, each eleven thousandths of an inch apart. To the left of this section of graduations we see the body of the scale graduated in inches, tenths and hundredths of an inch. At the right is seen the set of adjustment dots. In obtaining a measurement, any whole number of inches, halves, tenths or hundredths can be measured directly from the scale graduations; thus $2''$, $2\frac{1}{2}''$ (equals $2.500''$),

$2\frac{3}{4}$ " (equals 2.750"), 2.760 or any similar dimension which is an even multiple of hundredths of an inch, can be taken from the scale without any calculation. If we have a measurement not an even multiple of hundredths, we must use the special graduations, adjustment dots, and a brief setting calculation. In taking measurements from this scale, we should keep in mind that dimensions must be in multiples of 0.010", 0.011" and single thousandths. All measurements we desire to obtain, must be divided into these multiples and single units. To illustrate we will pick out a few measurements. Let it be required to find a dimension of 0.018" on this scale. Looking over the graduations, we see that the first dot is 0.012" from the first graduation, and each dot adds 0.001". We therefore take the distance from the first line of graduation to the seventh dot as giving our required dimension, because we have six one thousandth inch spaces between the first and seventh dot. The selection of this dimension requires no calculation if the learner has studied the scale.

Suppose we are to find a dimension of 0.031"; an inspection of this dimension will show the following possible divisions:

$$0.03" + 0.001" \dots 0.02" + 0.011" \dots 0.01" + 0.021"$$

It is evident that we cannot use the scale to obtain a division of $0.03" + 0.001"$ because we have no means of setting for 0.001" as it is not a multiple of 0.011", and we must use this section of graduations for setting any dimension not divisible into an even number of hundredths. Looking at the second division we immediately see that we can obtain the dimension by selecting two one hundredth graduations and one eleven thousandth graduation.

From the above we may deduce a rule as follows: To obtain selection for a dimension divide it into inches

and even hundredths of an inch; divide the remainder left over by 0.011 and the result will give number of 0.011" graduations to be used in connection with the hundredths of an inch, in making up the whole dimension.

Any dimension which cannot be divided as just outlined must be obtained by use of adjustment dots as outlined in discussing the first dimension of 0.018".

To illustrate this application we will take off a few more dimensions. First 0.059"; this dimension may be divided as follows: 0.050" + 0.009" or 0.040" + 0.019" or 0.030" + 0.029" or 0.020" + 0.039" and so on; the remainder is not divisible by 0.011 in any case; we must therefore use adjustment dots and 0.011" graduations to make up the dimension. In the adjustment dots we have available dimensions of 0.012", 0.013", 0.014" and so on up to 0.019". Therefore in setting out this dimension we will select any multiple of 0.011 from our required dimension which leaves a remainder of more than 0.012" and less than 0.019". If we select four 0.011" divisions we have a remainder of 0.015" which can be obtained by using the 0.012" space and three 0.001" spaces. To obtain this whole dimension we select four 0.011" spaces and the fourth dot in the line of adjustment dots.

The dimension 1.743" is handled as follows:

1" + 0.74" + 0.003"	remainder not divisible by	0.011
1 + 0.73 + 0.013"	" " "	0.011
1 + 0.72 + 0.023"	" " "	0.011
1 + 0.71 + 0.033"	" is "	0.011

The selection of graduations in this case is 171 hundredth graduations and three eleven thousandth graduations.

In practice the number of 0.011" graduations to be used in taking off any dimension can be rapidly determined by selecting the number of such divisions in-

indicated by the thousandth figure in the dimension. For example, in the above the thousandth figure is $3 \dots 3 \times 0.011" = 0.033"$ the portion of the dimension which must be taken on the special graduation section of the scale. Subtract this from the whole dimension and we have the portion which must be taken from the hundredth section of graduations. In the use of this scale the adjustment dots are needed only for dimensions of

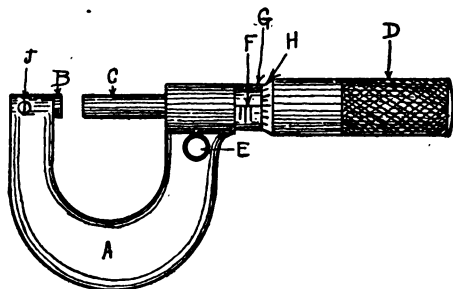

Fig. 21

- | | |
|--------------------|--------------------------------------|
| A. Frame. | F. Index line of barrel graduations. |
| B. Anvil. | G. Barrel. |
| C. Spindle. | H. Thimble graduations. |
| D. Thimble. | J. Anvil adjustment clamp screw. |
| E. Clamping screw. | |

The thimble and spindle assembly is called the head. Clamp screw *E* enables the workman to clamp the spindle in any desired position, and use the instrument as a gage.

less than $0.100"$. The scale we have been studying is quite useful to the expert machinist in laying out very accurate work.

The next method of subdividing the inch is by means of the micrometer caliper. This instrument is used for determining measurements as small as one ten thousandth of an inch, but for general use in the shop the division is to $\frac{1}{1000}$ of an inch. The instrument mentioned is shown in Fig. 21. Note particularly the names of the different parts of the tool as given in this illustration.

In studying the method of reading this caliper, reference is made to Fig. 21. The spindle is formed, inside of the thimble, into a screw, which runs in a nut contained in the barrel of the micrometer. This screw requires 40 complete revolutions to cause it to move a linear distance of one inch; hence, one complete revolution will cause the spindle to move $\frac{1}{40}$ of an inch. Around the lower edge of the thimble is a series of graduations, 25 in number, and along the barrel, parallel with the axis of the same, is placed an index line. Now if we move the thimble over one graduation relative to this index line, we must have moved the spindle a linear distance of $\frac{1}{25}$ of $\frac{1}{40}$ of an inch, or $\frac{1}{1000}$ of an inch.

In order to enable the machinist to read his micrometer quickly, every 5th graduation around the thimble is numbered, and each 4th graduation along the barrel is extended and numbered, so that for every extended graduation on the barrel, we read $\frac{1000}{10000}$ of an inch; and for each one of the smaller graduations on the barrel, we read $\frac{250}{10000}$ of an inch; and for the proportions of the $\frac{250}{10000}$ of an inch graduations, we read the marks on the edge of the thimble. Adding all of these together, we have the total length of the measurement sought.

To illustrate, suppose we wish to set our micrometer to $\frac{457}{10000}$ of an inch. The reading would be four of the extended graduations on the barrel, making $\frac{4000}{10000}$ of an inch; plus two of the smaller graduations, making $\frac{500}{10000}$ of an inch; plus seven of the graduations around the thimble, thus bringing the seventh graduation on the thimble even with the index line on the barrel: giving us a sum of $\frac{457}{10000}$ of an inch.

Set your micrometer caliper to the following dimensions for practise: $\frac{300}{10000}$ of an inch, $\frac{600}{10000}$, $\frac{900}{10000}$, $\frac{450}{10000}$, $\frac{750}{10000}$, $\frac{950}{10000}$, $\frac{263}{10000}$, $\frac{437}{10000}$, $\frac{562}{10000}$, $\frac{625}{10000}$, $\frac{752\frac{1}{2}}{10000}$, $\frac{833\frac{1}{2}}{10000}$, $\frac{998\frac{1}{2}}{10000}$.

The Vernier Caliper. — This instrument is used for the same purpose as the micrometer caliper, but is more convenient for taking off the larger dimensions. As the vernier scale is used on several different tools, it is taken up in another chapter (see chapter on calculations), to which the learner is referred for detailed instructions relative to the use of this instrument. The reason for using a vernier instead of a micrometer caliper for dimensions running from four to six inches, is that the vernier is much more convenient to handle on such work and is lighter, thus permitting a more delicate touch to be effected when using the tool.

The Standard Gage. — In Fig. 22 is shown what is known as a standard snap gage. This device is not adjustable, but is used as a permanent gage for sizing various classes of work. These gages are furnished in both plug and snap form, and in Fig. 22 we see a combination plug and snap gage. In using these gages, they should never be forced

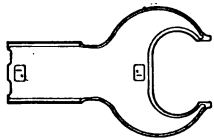

Fig. 22

into or over the work, but should be applied with great care and skill, otherwise they will soon become useless for maintaining an accurate standard size.

In Fig. 23 we have a plug and a ring gage. These are used for the same purpose as the plug and snap gage just mentioned. They are somewhat more serviceable however, though the ring gage is not as convenient for use

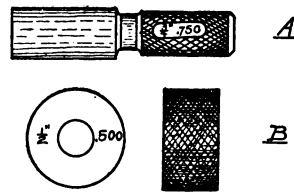

Fig. 23

A is an internal gage.
B is an external gage.

as the snap gage, especially when working on the lathe.

In Fig. 24 may be seen a taper plug and a socket gage.

These are used for measuring various kinds of tapers used in the machine shop. The details of using such gages are taken up in connection with taper turning on the lathe.

A.B.

Fig. 24

A is an internal gage.
B is an external gage.

The machinist is called upon not only to measure linear work, but to measure angular work as well. Angles are measured in portions of the circumference of a circle, known as degrees. These are subdivided into smaller parts, known as minutes, and these minutes are again subdivided into seconds. We have then the following table for use in angular measurement:

60 seconds = 1 minute
60 minutes = 1 degree
360 degrees = 1 circumference

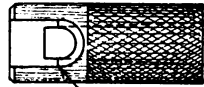
The Try-square. — One of the angular measuring tools is known as a try-square, and is illustrated in Fig. 25.

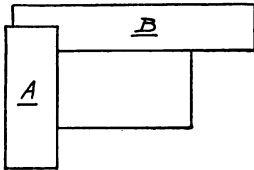

Fig. 25

A is the hilt.
B is the blade.

The most common angle used in machine shop practice is equal to $\frac{1}{4}$ of a circumference, or 90 degrees. Because of this fact, a tool has been developed which accurately measures this angle, without any necessity for adjustment on the part of the machinist. This tool is shown

in Fig. 25, and is known as the try-square.

Whenever we wish to determine whether or not two surfaces are at right angles, we place one part of the square against one surface, and draw the other part

down against the other surface. If we can see between the square and the work at any place, then the two surfaces are not at an angle of 90 degrees with each other, or, as expressed in the shop, the work is out of square. Look at Fig. 25, and note particularly the names of the different parts of the try-square. The use of this tool, as described above, is illustrated in Fig. 25.

Try-squares may be obtained with both hard and soft blades. The hard blade square is rather more serviceable than the soft blade square. The young machinist will very early find a great deal of use for this tool in his work. It should be used carefully, as an inaccurate square often creates a great deal of trouble for its owner.

Testing the Try-square. — As the machinist must have an accurate square, it will be of interest to him if we

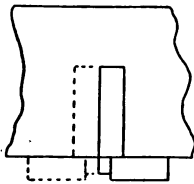

Fig. 26

study a method of testing it. Probably the simplest method is first to obtain a cast iron plate which has been accurately planed on the surface and on the edge. Then place the hilt of the square against the planed edge, as shown in Fig. 26, allowing the blade to lie flat on the surface, and with a sharp instrument, known as a scratchawl, draw a line on the plate along the blade of the try-square. Now reverse the square, as shown in the dotted lines, and see if the edge of the blade can be made to conform to the line previously drawn on the plate. If so, the square is sufficiently accurate for a machinist's work, if we consider the outside edge of the blade alone.

He should now take his micrometer caliper and measure the width of the blade, to see if it is parallel. If so, the square may be regarded as accurate on both the inside and the outside edge of the blade.

Assuming that we do not find the square to be true, it

must be filed, if a soft blade, or ground, if a hard blade, until it meets the requirements of the tests mentioned above.

The Bevel Protractor. — This tool is illustrated in Fig. 27, and is used by the machinists for measuring the various angles commonly met in shop practice. Note the names of the parts shown in the illustration. A careful study of the tool will reveal a series of graduations engraved on the dial base. The dial itself has an index line, and when this line coincides with zero on the base graduations, the angle between the blade and the hilt is zero, that is, the blade is parallel with the hilt. The

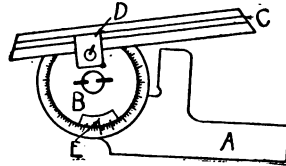

Fig. 27

- A. Hilt.
- B. Dial.
- C. Blade.
- D. Clamp.
- E. Index line.

blade may be set to any angle with the hilt, by placing the index line on the dial in coincidence, or in line with, the particular graduation indicating the number of degrees.

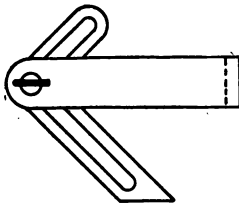

Fig. 28

The Bevel. — This little tool is shown in Fig. 28, and is used for the purpose of transferring angular measurements from the protractor to various pieces of work. There are many jobs on which it is not convenient for the machinist to use the protractor directly, because of insufficient room. The bevel is a

much smaller tool, so the protractor may be set to the required angle, this angle transferred to the bevel, and the bevel used in a confined space.

We have now considered the more elementary features of machine shop practice, and the common measuring systems with which the young workman will come in contact.

26 PRACTICAL MACHINE SHOP PRACTICE

The student should carefully review the material in this chapter, and be sure that he thoroughly understands it before going farther in the work.

QUESTIONS

1. What knowledge, of a technical nature, should a workman possess in order to meet the requirements of the machinist's trade?
2. Describe and illustrate, by means of a sketch, the proportions and parts of the machinist's bench.
3. Describe the proper method of using a hammer and cold chisel.
4. Name the more commonly used files, giving the various cuts available, and the necessary specifications for ordering a file.
5. Describe the proper method of using a file.
6. Describe the process of scraping, and tell why this process is necessary.
7. Give a brief outline of the development of the modern measuring systems for linear and angular measure, and give the tables for these measures.
8. Give a brief description of the steel scale, commonly used by machinists.
9. Describe and illustrate the micrometer caliper, and tell why this instrument is necessary in present day machine shop practice.
10. Name and illustrate the various standard gages used in present day machine shop practice.
11. Describe a good method of testing a try-square.

CHAPTER II

SUPPLIES AND MISCELLANEOUS TOOLS

IN this chapter we will take up a number of different tools, studying them with some degree of care, so that the learner is thoroughly acquainted with the name of each tool and its component parts. He will also gather some information concerning the proper method of using them. We will furthermore study some of the materials other than metals, which are used in the machine shop.

The first tool is a very simple one, known as the center punch, and is shown in Fig. 29. This tool is used by the machinist in two forms:

one, a rather heavy tool about $\frac{1}{2}$ an inch in diameter and 4 inches

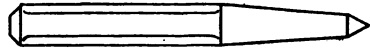

Fig. 29

long, with the end sharpened to an angle of approximately 90 degrees. This is used for stamping in the centers in which drills are to be started when drilling holes, hence the name, center punch. The other type of this tool is often spoken of as a prick punch, and is usually not over $\frac{3}{8}$ of an inch in diameter and 3 inches long, with the point ground to an angle of approximately 60 degrees. This is used for marking off lay-outs on metallic surfaces.

Calipers. — Figure 30 shows an outside caliper, which is used for testing the dimensions of work. It is ordinarily set to dimension from the steel rule, and in doing this setting, the workman should hold the rule and caliper as shown in Fig. 30, in order that he may look across the end of the caliper leg onto the graduation of

the scale. An outside caliper is specified in size according to the dimension indicated by the line *A B* in Fig. 30.

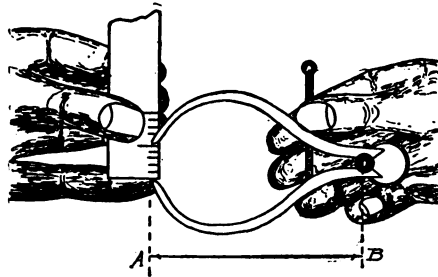

Fig. 30

Thus, a 6 inch outside caliper will measure 6 inches between these points; the same is true of inside calipers, dividers, etc.

Concerning the use of the caliper as a tool, the machinist finds it one of the most convenient devices for measuring diameters and lengths accurately.

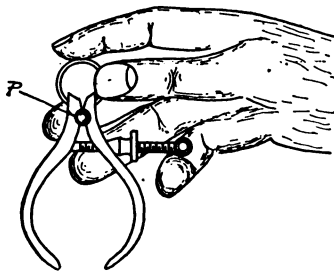

Fig. 31

The proper method of holding it is shown in Fig. 31. Note particularly the way in which the tool rests on the fingers. In order to test accurately by the use of any kind of a caliper, the machinist must develop a very delicate sense of touch,

and from the beginning he should never permit himself to make a careless measurement by roughly pushing the caliper over the work. Each time he does so, he has lost an opportunity to develop his sense of touch.

The inside caliper is used for measuring dimensions in confined spaces. The method of its use is shown in

Fig. 32, and all that has been said relative to the outside caliper holds true in the use of the inside caliper. An operation which the machinist is often called upon to perform, is the transferring of a size from the outside to

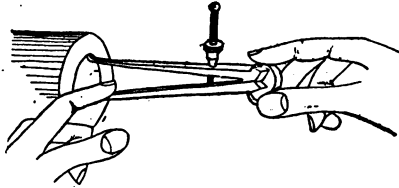

Fig. 32

the inside caliper or vice versa. The method of holding the tools for carrying out this operation is illustrated in Fig. 33. Holding the inside caliper in the right hand, one leg should be set on the outside caliper as shown in the illustration, and swung back and forth as indicated by the arrows. While moving the inside caliper in this

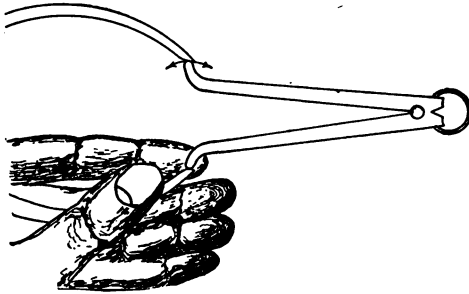

Fig. 33

manner, the adjustment nut is turned with the thumb and forefinger of the right hand until the swinging point of the inside caliper, just touches the corresponding point of the outside caliper. If setting an outside to an inside caliper, the inside caliper is held in the left hand and the outside caliper adjusted as described. The set-

ting requires some skill, but continued practice, carefully taken, will give the desired control.

The Hermaphrodite Caliper. — This tool is illustrated in Fig. 34, and is used in laying out lines on surfaces at required distances from edges and shoulders. It is un-

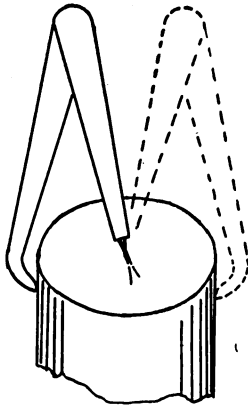

Fig. 34

necessary to present very many illustrations of the application of this tool, because, as the apprentice advances in his trade, he will find many places where it will be of use. One of the most common applications of it, however, is in connection with the locating of the center of a piece, when preparing it for turning in the engine lathe. In doing this work, the bent leg of the caliper is placed at any position on the circumference of the piece, and while being held thus, a short arc is scribed on the

surface, which has previously been marked with chalk or coloring acid. The tool is then transferred to the position indicated by the dotted lines, and a similar arc struck. Then, moving the tool around the circumference of the piece approximately 90 degrees, another arc is struck, and the same operation is repeated at the opposite end of the diameter. After a few trials we are enabled to locate accurately the center of the piece, which we mark with the center punch, preparatory for drilling.

There are a number of other kinds of calipers on the market which are useful, but the ones described are those most commonly used, and may be regarded as fundamental tools of this type. It is suggested that the young worker obtain the catalogue of either The Brown and Sharpe Mfg. Co., Providence, R. I., or The L. S.

Starrett Co., Athol, Mass., and study the tools which are manufactured by these firms.

The Divider. — The next tool for consideration is the divider, which is used for scribing circles on work and setting out dimensions, when laying out preparatory to machining or finishing. It is illustrated in Fig. 35. In using it, the dimension is first taken from the scale, as shown in the figure just mentioned, a center is placed on the piece which we wish to lay out, and by swinging the divider about this, with the point of one leg resting in the center, the required circle is formed. In order that this "layout" may not be rubbed out in the subsequent handling of the piece, it is wise to mark the circle with eight or ten prick punch marks, approximately equally spaced about the circumference.

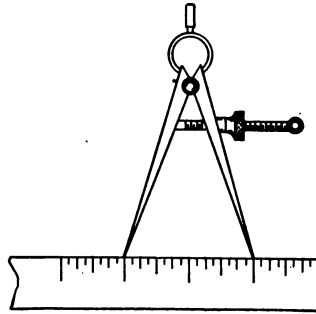

Fig. 35

The Scratch-Awl. — This tool is sometimes spoken of as a scriber, and is illustrated in Fig. 36. Notice that one end of it is bent over, and the reason for such a formation is, that occasionally it is necessary for the machinist to reach into out of the way



Fig. 36

places to mark a line. With the straight end of the scriber it is not possible to do this. The straight end of the scriber is used for striking lines from a straight edge, or the edge of a try-square, when making layouts.

The Straight Edge. — This is a very simple tool, but quite useful to the machinist in his work. It may be applied in the process of testing surfaces when filing, scribing lines between centers when laying out work,

accurately measuring lengths between shoulders on work, and many other operations. As found on the market, the tool is a piece of steel accurately machined and finished, hardened and tempered.

The Center Square. — This tool greatly facilitates the location of the center of a cylindrical piece of work.

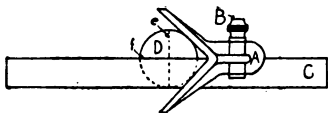

Fig. 37

- A. Head.
- B. Clamp nut.
- C. Blade.
- D. Work.
- E. First line struck.
- F. Second line struck.

One method of locating such a center, has been described in discussing the hermaprodite caliper. Recalling this description we are reminded of the necessity for making several trials before finally locating the center. With the center square this work is greatly facilitated, and an illustration of its application is shown in Fig. 37.

To locate the center of a cylindrical piece, press the head firmly against the body of the cylinder, being certain that the blade is solidly clamped in the head, and with a scratch-awl, strike a line across the end of the piece. Now move the center square approximately 90 degrees around the circumference, and strike another line. The intersection of these two lines gives us the center of the work.

As to the theory of this tool, we have a practical application of a simple geometrical theorem, the discussion of which is not necessary in a book of this sort; but by way of suggestion to those who may be interested in studying the subject, it is stated that the tool is based on the fact that the bisector of any chord of a circle passes through the center of that circle.

The Surface Gage. — This is a tool which is used for many testing operations on both the machine and the

bench. In discussing various classes of work in later portions of this book, this tool will probably be mentioned a great many times, so, if he carefully studies the text, its use will be clear to the learner. A modern type

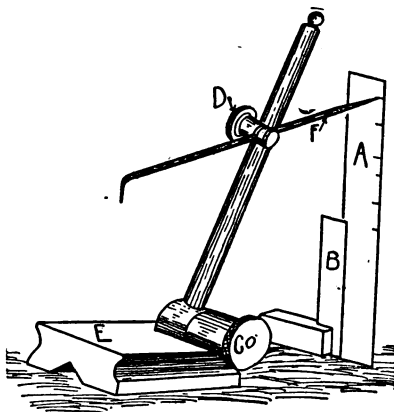

Fig. 38

- | | |
|----------------|-----------------------|
| A. Scale. | D. Needle nut. |
| B. Try square. | E. Surface gage base. |
| C. Staff nut. | F. Needle. |

of this tool is illustrated in Fig. 38, where we see it properly set up for transferring a dimension from a scale to the surface gage.

Notice that the bottom of the surface gage is cut away in a V-form. This permits the use of the tool on cylindrical surfaces, where occasionally the machinist finds it necessary to make layouts requiring the use of this tool.

On certain occasions it is necessary that the machinist locate the center of a cylindrical piece with great accuracy. Neither the hermaphrodite caliper, nor the center square give sufficiently accurate results for the demands of some of the more intricate operations in machine shop practice. When such a job comes to hand, the machinist

uses the surface gage, as illustrated in Fig. 39. The piece, usually, has been turned or otherwise machined, so that the outside surface is accurately true. To locate the exact center of this piece he procures a V-block, as shown in the illustration, and lays the work in it. He

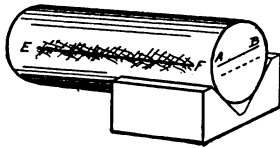

Fig. 39

then sets the scribing or pointed end of the surface gage needle (after having colored such portions of his work as he desires with "coloring acid,") to what he thinks is the center of the work, and strikes a line

across the end of the piece, as indicated by the full line. He then revolves the work in the V-block, so that the end of the line *A* comes to the position of the end of the line at *B*.

He then draws his surface gage needle across the end of the work, as shown by the dotted line. Now if the end of the surface gage needle was located in the plane of the center of this piece, the second line would exactly coincide with the first. If it does not do so, it will be necessary to make adjustments until we get such a result.

Having located accurately the center of the piece, let us study the application of this process to a typical machine shop job. It is oftentimes necessary to accurately bore a hole through a cylindrical piece, perpendicular to the center line, as is shown in Fig. 39 *B* and the center for boring the hole *H* is located by an application of the process just mentioned. Let us proceed from the point in our discussion where we had located the center of our piece of work. Place some coloring acid on the surface of the cylinder, as indicated by the cross shaded portions of the work in Fig. 39, and, being very careful not to change the setting of the surface gage needle, strike a

line *E F* along this surface. This gives us a line on the surface of the cylinder which is in the plane of the center, that is, this line is the same distance from the surface plate face as the line which passes through the center of the piece.

Now we come to the application of the use of the surface gage on cylindrical work. Assuming that the center of the hole which we wish to bore is to be two inches from the end of the piece, we place the clamp *G* Fig. 39 *B* (which comes with the surface gage when we

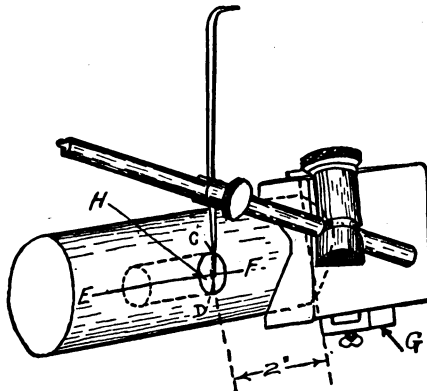

Fig. 39 B

purchase it) on the base as indicated. Now throw the staff of the gage down, so that it lies approximately parallel with the lower surface of the base of the tool, and set the needle on the scale to a dimension of 2", all as illustrated in Fig. 39 *B*. The surface gage is placed on the piece of work as shown in this figure, and a short line scribed as shown at *C, D*, intersecting the first line *E F* Fig. 39 *B*. We have now located the center of the hole which we wish to bore, with sufficient accuracy for the usual run of machine shop jobs. With the center punch

this location is marked, and by the use of the divider the layout is completed, and the work is ready for the drill press or boring mill. Drill press work will be taken up in a later chapter.

The Key Seat Rule or Box Square. — Another very useful tool for the machinist, is the key seat rule or box square which is illustrated in Fig. 40. This tool derives its name from the fact that it is used for laying out key seats, and its application in practice is shown in the figure already mentioned. In studying the use of this tool, we must remember that the edges of a key seat must be parallel with the center of the piece in which they

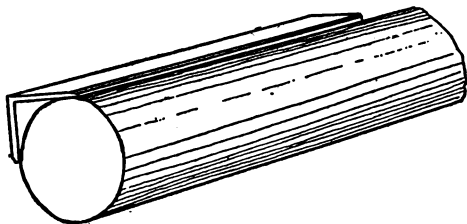

Fig. 40

are made. By laying this rule on the surface of a cylinder, we can easily scribe a line parallel to the axis, and such a line will give the location of a key seat. By locating one such line, setting the divider to the required width of the key seat, scribing a small arc, and striking another line by means of the key seat rule and scribe, tangent to this arc, we have the two faces of the key seat, which we desire to cut, properly located. The work of cutting key seats in the machine will be described later in the text. The construction of the key seat rule is based on the same geometrical theorem as the center square.

The Spirit Level. — This device is used for leveling work, either on the bench or on the floor. Before using his level, the machinist should test it for accuracy. This

test is made by leveling a piece with the tool, set as shown in Fig. 40 *B* and this should be accurately done. The level is then reversed, placing end *A* in the position of end *B*. If the bubble in the glass of the instrument

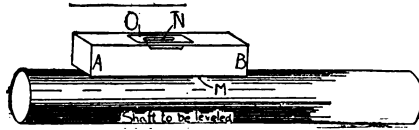

Fig. 40 B

M. Body. *N.* Bubble glass. *O.* Bubble glass plate.

does not change in position, due to this reversal, it may be regarded as reasonably accurate. By a careful study of the illustration, the learner will become acquainted with the parts of this tool, which are spoken of in the following description of its method of use. In determining whether or not work is level, the machinist simply sets the tool on the piece to be tested, and when the work is level, the bubble in the bubble glass should stand midway between the ends of the opening in the bubble plate. If this is not the case, such adjustments must be made as

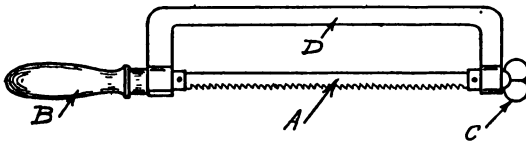

Fig. 41

A is the blade. *C* is the tension screw and nut.
B is the handle. *D* is the frame.

are necessary to bring about that condition. The level is used in setting up machinery, aligning shafting, and other mill-wrighting work.

The Hack Saw. — Figure 41 shows the tool known as a hack saw. The illustration shows both the hack saw

and the frame. The saw which is shown at *A*, is removable, and in the shop this is more often spoken of as a hack saw blade. When this blade is worn out, it is removed from the frame, and a new one substituted in its place. When ordering hack saw blades, the particular trade name applying should be given, also the length and the "point." Montgomery & Co., of New York, issue a catalogue which presents various kinds of hack saw blades, and the number of points commonly furnished on stock saws. The term "point," as used above, refers to the number of teeth per inch of length of the blade. For example, a specification as follows: one dozen 10-inch, 14 point Star hack saw blades, would imply that you wanted twelve hack saw blades of the Star make, having 14 teeth per inch of length, each 10" long. The machinist uses this tool for cutting any kind of metal which has not been hardened. Do not apply great pressure, nor move the saw at more than 40 strokes a minute. Such use will insure rapid cutting and a long life.

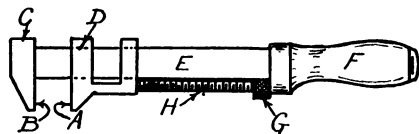

Fig. 42

C is the solid jaw.
D is the sliding jaw.
E is the bar.

F is the handle.
G is adjusting screw head.
H is adjusting screw.

The Monkey Wrench. — This tool is used for tightening and slacking bolts and nuts, whenever such work may be necessary. It is shown in Fig. 42, and the apprentice should carefully study the names of the various parts. Whenever it is possible to do so, a monkey wrench should be used so that the stress is applied as indicated in Fig. 42, by arrow *A*, and *not* as indicated by arrow *B*. Do not use the monkey wrench as a hammer.

All of the tools thus far mentioned are usually owned by the machinist himself, being of a general nature which each individual man prefers to have as his personal property. A great many of the tools used in the machine shop are of a special nature, and are supplied by the company operating the plant. Among these we find such tools as mandrels, dogs, taps, reamers, solid wrenches, drills, etc. Some of the more important of these will be briefly described in order that the beginner may have an understanding of their proper use.

Lead Hammer. — Figure 43 illustrates a lead, or soft metal hammer, which is used when driving finished pieces

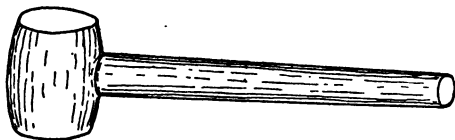

Fig. 43

of machinery together. No finished piece of machinery or any finished tool should ever be struck with a steel hammer. Invariably a lead or copper hammer, preferably lead should be used.

The Mandrel. — This tool is illustrated in Fig. 44, where it is shown supporting a piece of work. In using this, the piece which is to be finished is first drilled and reamed (see p. 40 for description of a reamer) then the mandrel is driven into the hole thus made, and placed in the lathe. The mandrel always drives firmly into the work; never drive it into place without first putting a little oil on it. The firm drive gives sufficient holding power to take the necessary cuts when operating on a piece in the lathe. Mandrels are kept in the machine shop in all sizes from $\frac{1}{4}$ " to 2" diameter, usually varying by sixteenths of an inch; mandrels are made very slightly tapering in the body.

The Dog. — In the illustration at *A* is shown a “dog” or “carrier.” This tool is placed on the end of the mandrel, which has been turned down and slightly flattened, so that the set screw in the dog readily finds a seat. Dogs are sized by the diameter of the hole in the body; thus a

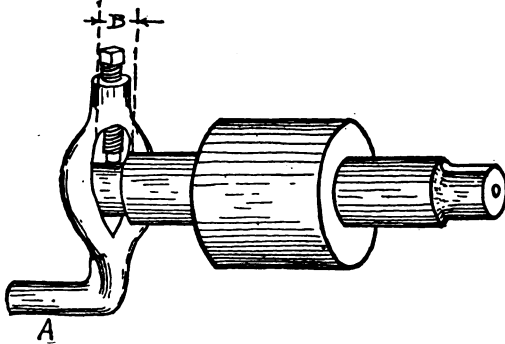

Fig. 44

dog which had a dimension as indicated at *B*, Fig. 44, of one inch, would be known as a one inch dog. The equipment of this tool usually ranges from $\frac{1}{2}$ an inch to 6 inches, varying by $\frac{1}{4}$ of an inch from $\frac{1}{2}$ an inch to 2 inches, and by $\frac{1}{2}$ an inch above this size.

Reamers. — Figure 45 illustrates a tool which is used for finishing holes to an exact diameter. When a hole is drilled in a piece of stock, the size of the drill used is

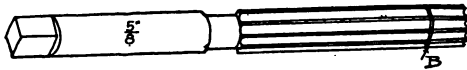

Fig. 45

usually from 0.010 to 0.015 of an inch smaller than the required finished size. This stock is left, so that the reamer may be used in accurately finishing the hole. The reamer is made about 0.015 of an inch under size at the end of the teeth, coming to its full size at a point

distant from the end about equal to the diameter of the reamer, as indicated at *B* of this figure. In using a reamer, regardless of whether it is passing into or out of the work, it should invariably be turned in a clock-wise direction. Usually, in reaming a hole, it is simply pushed through the hole, constantly turning it as the pressure is applied.

The drill which is used for drilling the hole before reaming, is spoken of in the shop as a "reamer drill." One should not understand from this statement that the drill is in any way different from other drills, so far as its design is concerned. A reamer drill is simply 0.010" or 0.015" smaller in diameter than the finished size of the hole which is to be made.

Taps. — A tap is shown in Fig. 46. This is a tool used for cutting threads on the inside of holes of small and moderate diameters. Taps are made in all the standard sizes of threads. The thread most commonly used in this country is the United States

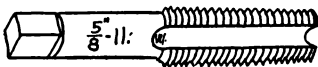

Fig. 46

standard thread. The table of U. S. standard threads is given on page 284 (table 2) and the young worker should memorize this table. A hole which is to have a thread tapped in it, must be drilled smaller than the outside diameter of the tap which is to be used in cutting the thread. The reason that this is necessary is because there must be some stock from which to form the thread.

Drills used for making holes which permit tapping, are known as tap drills. Like the reamer drill, this drill is in no way different in design from standard size drills, but it is enough smaller than the nominal diameter of the hole, to permit the formation of the thread, by the tap. Table 2 gives diameters of the commonly used tap drills.

Wrenches. — Besides the monkey wrench a number of other wrenches are used in the machine shop. Figures 47 to 52 are illustrations of these wrenches. Figure 47



Fig. 47

shows an alligator wrench, used for operating on cylindrical work, where great stress is not necessary.

Figure 48 is a Stillson wrench, used in pipe fitting and on cylindrical work, where considerable stress must be applied in working. Figure 49 shows a straight open end engineer's wrench, used for

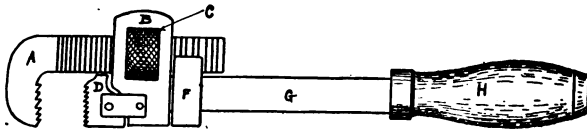

Fig. 48

A. Movable jaw. B. Head. C. Adjusting nut. D. Fixed jaw. E. Bar. F. Thrust yoke. G. Bar. H. Handle.

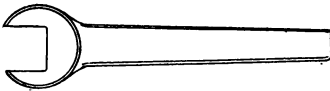

Fig. 49

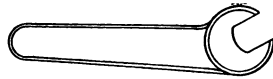

Fig. 51

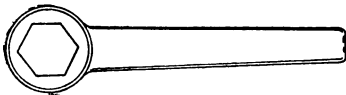

Fig. 50

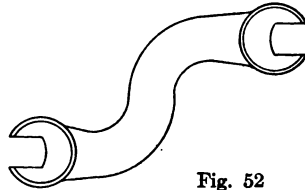

Fig. 52

setting up bolts and nuts. Figure 50 shows a straight hexagon box wrench, used for same work as open end wrench, but on work where heavy stresses must be applied. Figure 51 shows a 15° offset open end engineer's wrench, used for setting up bolts and nuts located in inaccessible places which cannot be reached by a straight

wrench. Figure 52 is an open end S-wrench used for inaccessible places.

The Center Gage. — Figure 54 is a small tool known as a center gage. The angle at *A* is the same as that to which the center on the engine lathe must conform, and the small notch at *B* is the same angle as the sides of the U. S. standard thread. This tool is used for grinding the cutting tool with which the machinist cuts a thread, on the lathe. It is also used to test the correctness of the angles on the centers of his lathe.

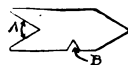

Fig. 54

We now come to the consideration of supplies which the machinist uses in doing his work, and since we will have occasion to use it in ordering some of the supplies, the table of paper measure is given below:

24 sheets	= 1 quire
20 quires	= 1 ream
2 reams	= 1 bundle
5 bundles	= 1 bale

In ordering emery cloth, it is always purchased by the quire or ream. In order that the machinist may be able to select an emery cloth which shall meet the requirements of the many jobs which he has to finish, it is graded according to the coarseness of the emery which is used in making it. The system of grading is according to numbers as follows:

00	is flour emery cloth
0	is 120
$\frac{1}{2}$	is 90
1	is 80
$1\frac{1}{2}$	is 70
2	is 60
$2\frac{1}{2}$	is 54
3	is 46

The second set of figures in this table gives the size of the emery which is placed on the emery cloth.

Emery, itself, is not numbered in the same way as the cloth, but is graded according to the number of openings measured in one inch of length of a sieve through which the emery will pass. For example #120 emery will pass through a sieve having 120 openings in one inch of length, #90 will pass through a sieve having 90 openings per inch of length, and so on.

Emery cloth is made by sifting emery over the surface of a cloth which acts as a backing to carry the emery. It is used for polishing work at the bench and in the lathe. The mechanic commonly wraps it around a file for finishing a small surface. In polishing a surface, the coarser grades of cloth are used for finishing directly after the file has been applied, the final polish being produced by means of a piece of worn out cloth wrapped around a file, and a little oil dropped on the surface of the work, in order to remove the harshness of the finish.

Cotton Waste. — This is another article of supply much used in the metal working trades. It may be obtained in either white or colored stock, and is commonly sorted into various grades by manufacturers. These grades are sometimes numbered and sometimes named. Waste is sold in bales of fifty and one hundred twenty-five pounds, or for small quantities it is sold by the pound. A typical classification as cataloged by one large supply firm is as follows:

- First grade white as XXX. Spoken of as "triple X."
- Second grade white as XX. Spoken of as "double X."
- Third grade white as X.

Colored waste is supplied in grade #0.

For machine shop work, white waste, grade X is very satisfactory.

Oakum is often used by the machinist when on erecting or jobbing work, for packing certain kinds of pipe joints, and calking wood tanks or vats used in some plants. The specification used when ordering this material may call for "plumber's spun oakum." It may be purchased by the pound in small lots, or in bales of fifty pounds each.

Wire and Drill Gages. — One of the confusing things to the young mechanic when he first enters the shop is the system of gages used to designate the sizes of wire, small drills, machine screws and the thickness of steel plate. A number of such systems are in use, and each of them differs from the other for corresponding numbers by relatively small dimensions, yet this difference is sufficient to cause troublesome errors if one gage number is mistaken for the other. In table III we have given the systems most commonly met in machine shop practice of the present day. These include the American or Brown and Sharpe gage, the Birmingham or Stubbs wire gage, the Imperial wire gage, and the Stubbs steel wire gage, together with the U. S. standard plate and steel music wire gage.

It will be noted that the first column in the table gives the number by which the gage is designated in the trade. A study of these numbers shows us that #1 is 0.289 + on the American or Brown and Sharpe Gage, while it is 0.281 + on the U. S. Standard Plate Gage. Looking along the line which gives the diameters for the various other gages corresponding to #1, we see that each gage differs from the others as already mentioned.

By way of explanation of the method of using these gages, the learner should remember that the decimal corresponding to the number given, indicates the diameter in decimal fractions of an inch, which corresponds to the gage number. The numbering of these gages

is purely arbitrary, and each one has been introduced for the purpose of meeting some demand at the time of its development.

The American or Brown and Sharpe Gage appears to have a logical scheme of number arrangement, for in this gage the diameters for the designating numbers increase by a regular geometrical progression. The largest dimension in this gage is #0000, the corresponding diameter for this number is $0.46 +$

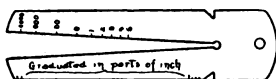

Fig. 55

of an inch: the next smaller number is #000, and it is obtained by multiplying 0.46 by the constant 0.890522 ;

this product is multiplied by the same constant in order to get the next smaller diameter, and this operation is repeated until all of the numbers of the gage have been calculated.

The Imperial Wire Gage does not differ a great deal from the English. It was introduced in 1884 by the English Board of Trade as a substitute for the Birmingham Gage.

The Stubbs Steel Wire Gage differs considerably from the Imperial, English, and American. Its numbers range from #1 to #80, the variations in diameter being indicated by the nearest 0.001 ", while the whole range of eighty numbers makes a total difference in diameter of only 0.214 ".

The gages used for indicating sizes of wire and plate are of two forms, the angular, shown in Fig. 55 and the notch shown in Fig. 56. The angular gage is used by sliding the screw wire or plate into the angular opening until

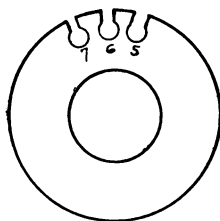

Fig. 56

Notch gage. Numbers around circumference give sizes of wire; notches are continued around whole circumference.

it touches both sides, and the reading opposite the point of contact will give the gage of the material. On one side of this gage, as supplied to the trade, we find the graduation for English and American standards, and on the other side a graduation for the machine screw gage and parts of an inch.

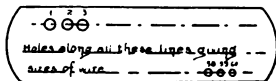

Fig. 57

The notch gage, as shown in Fig. 56, is used by passing the piece to be measured through one of the notches, making a close contact, the size being determined by the notch through which the piece will pass. This gage is on the market in both the circular and rectangular form.

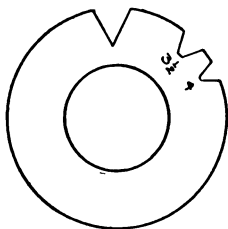

Fig. 58

Notches are carried around the entire circumference of the gage. Figure under each notch indicates number of threads per inch of U. S. Std. form, of same size as notch. The large V is used for grinding tools for cutting V threads.

The rectangular form is spoken of as a rolling mill gage, and is used for gaging sheet metals. They are not highly accurate, but are sufficiently so for the work that must be done with them. For the better classes of work, one should apply the micrometer caliper, using the table of decimal equivalents, corresponding to the various numbers of the different gages when measuring sizes. These wire gages are commonly made of tool steel carefully hardened and tempered.

In Fig. 57 is shown a gage for drill rod sizes, ranging from #1 to #60. A smaller one is on the market, having a series of holes ranging in size from #61 to #80. Drill gages, known as "jobber's gages" are on the market with holes ranging in size from $\frac{1}{16}$ " to $\frac{1}{2}$ " by sixty fourths of an inch. These are very useful when determining the sizes of the smaller

drills used in the machine shop, as it is not possible to stamp the sizes on these small tools.

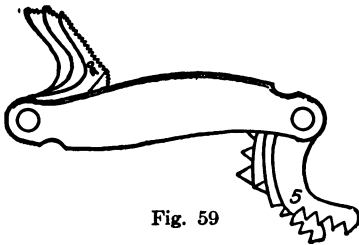

Fig. 59

threads. The other notches shown are flattened at the root, for the correct grinding of a U. S. standard thread, of the pitch shown opposite the particular notch on the gage. This gage may be obtained for the Whitworth and Acme standard, in addition to the standard already mentioned.

In Fig. 58 is shown a standard screw thread gage, which is used for grinding tools when cutting threads. The one large V. is all that is necessary for grinding tools when cutting V.

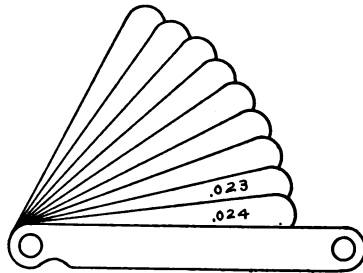

Fig. 60

Figures on leaves are thickness in thousandths of an inch.

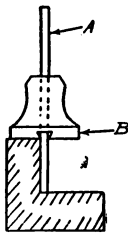

Fig. 61

A is the blade or scale.
B is the head.

In Fig. 59 is shown a screw pitch gage, which is a very convenient tool when one wishes to determine the number of threads per inch of length of a piece of work. Each one of the blades in this gage is cut to correspond to a given number of threads to the inch, and by laying these on a screw thread one may easily determine the pitch of the thread. On the blade is stamped the pitch number in each case.

The Thickness Gage.—In Fig. 60 is shown what is known in the shop as a thickness gage. This is made up of a number of thin steel leaves, varying by thousandths of an inch. These leaves may be used singly or together, thus enabling one to make up any desired dimension within the limits of the tool. This is a very valuable tool for the mechanic when making fine fits in machine work.

The Depth Gage.—The depth gage which is used for measuring the depth of holes is shown in Fig. 61, where an application of the tool is illustrated. The particular tool shown is equipped with a blade six inches long, graduated in sixty-fourths of an inch. Note the names of the different parts as given in the figure. A

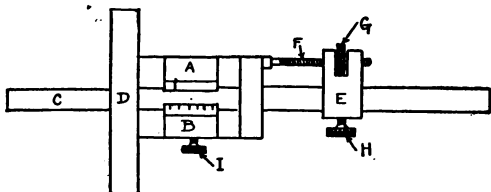

Fig. 62

- | | |
|--|---------------------|
| A. Scale for measuring in 64th of inch. | |
| B. Vernier scale for measuring in thousandths of inch. | |
| C. Blade. | |
| D. Head. | G. Adjusting nut. |
| E. Clamp. | H. Clamp set screw. |
| F. Adjusting screw. | I. Head set screw. |

more accurate type of this tool is known as a vernier depth gage, illustrated in Fig. 62. This consists of a vernier scale applied to a depth gage. The vernier is useful on the finer classes of work in the machine shop, where the first mentioned type of gage is not sufficiently accurate.

The Scratch Gage.—Figure 63 shows the scratch gage, which is used for laying off lines parallel to the

edge of a piece of work. The bar on this gage is graduated, starting from the point at which the marker is

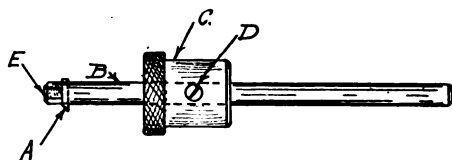

Fig. 63

- A* is the scriber.
B is the bar.
C is the head.
D is the head set screw.
E is the scriber adjusting screw.

located. Any required dimension may be easily laid off by simply sliding the head to the required position on the bar.

Trammel Points. — Figure 64 illustrates a pair of trammel points. These are really large dividers used for lay-

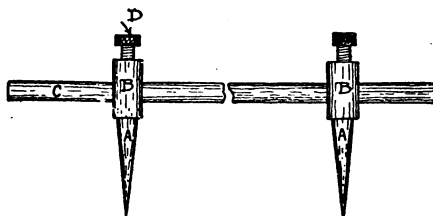

Fig. 64

- A.* Scribing points. *C.* Bar.
B. Trammel heads. *D.* Head set screws.

ing out large circular arcs. The points are commonly mounted on a wooden or steel beam, and are set from a scale. The scribing points may be removed from the heads *B*, and in their places there may be inserted either outside or inside caliper legs.

The Test Indicator. — This tool, illustrated in Fig. 65, is used in the lathe to determine small variations from

the true rotation of a cylindrical piece. It is also used quite largely in determining small inaccuracies of a plane surface, something after the manner of a surface gage. The graduations shown on the end of the bar indicate

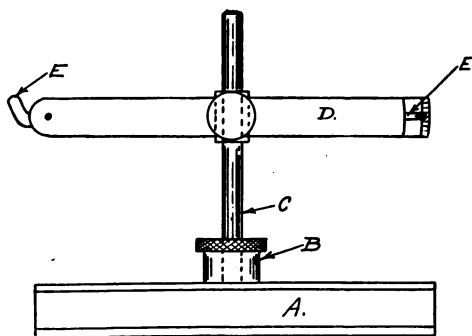

Fig. 65

A is the base. *C* is the staff.
B is the clamp nut. *D* is the indicator.
E is the indicator needle.

the number of thousandths of an inch variation from truth in the surface being tested. If the needle does not move at all when making a test, the piece of work is accurate.

The Center Indicator.— This tool is illustrated in Fig. 66, where its method of use is also shown. The

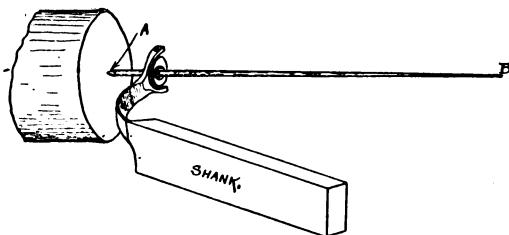

Fig. 66

piece of work has been placed in a chuck or on a face plate in a lathe, and the workman desires to set the piece

true to an established center. To do this he sets the piece approximately true by pushing the footstock center in the center punch mark which has been laid out on the piece, and lightly clamps the work in this position. He then places the end of the spindle *A* in the center punch

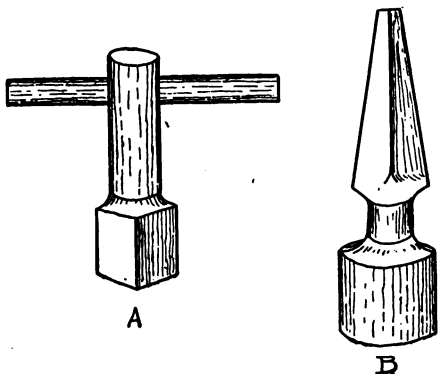

Fig. 67

mark, and revolves the lathe spindle by hand, noting movement of end of needle *B*. Adjustments are made, until the end of needle *B* remains stationary while the work is revolved. The shank of the indicator is held in

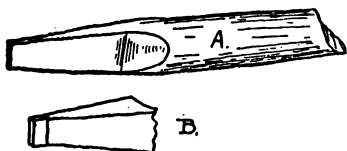

Fig. 68

the tool post, and the instrument is positioned by moving the carriage of the lathe.

Miscellaneous Tools.—

Under the heading of wrenches were discussed and illustrated a number of tools which may be regarded as of standard varieties. The machinist sometimes finds it necessary to use wrenches more or less special in their construction and two of these wrenches are shown in Fig. 67. The first one illustrated is a hand socket wrench,

while the second one is the brace socket wrench. These tools are used for removing nuts in inaccessible places. The second tool may be used in a brace and is therefore available for more rapid work than is possible with the hand wrench.

Figure 68 illustrates a little point in the making of a screw driver, which is often overlooked. The first one is ground on the end in such a way, that when we attempt to use it, it tends to damage the slot in the screw head, and to cause inconvenience by slipping out of place when the

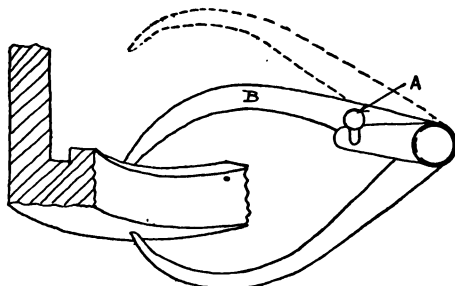

Fig. 69

pressure is applied. In the second illustration the faces of the screw driver are ground parallel, making a much more serviceable tool.

Transfer Calipers. — The illustration in Fig. 69 shows a transfer caliper which is used for taking off inaccessible dimensions. The method of operating is shown in this figure, where the caliper is set for a dimension back of a shoulder. In taking this dimension on the scale, the machinist will slack off the nut at *A*, which will release the leg *B*, after which the leg may be swung into a position indicated by the dotted lines. After removing the caliper from the piece by this means, the free leg is slipped back to its original position and the nut *A* tightened. The dimension may now be read from the scale in the usual manner.

Calipers are classified according to the type of joint which is used in fixing the parts of the caliper at the pivot point *P*, Fig. 31. The illustration shows a spring caliper, but in looking over a catalog one will find listed "firm joint calipers"; no spring is used in the construction of the firm joint tool. Some workmen prefer the firm joint to the spring caliper because it feels somewhat more solid in the hand, though the inconvenience of setting is an unfavorable feature. The lock joint caliper gives the solidity of the firm joint caliper, while it has a measure of the convenience of the spring caliper in adjustment. ¶

If the young mechanic will look over his small tool catalogue he will become acquainted with a great many different kinds of tools, which are of service to the machinist.

The Steel Marking Stamp.—The workman in the machine shop must have some means of marking the articles which he makes, and for this work the steel stamp shown in Fig. 70 is used. These stamps are figures and letters cut in the end of a piece of steel



Fig. 70

which is hardened after the letter is cut. A separate stamp is used for each letter or number. In using these stamps the work can be more accurately aligned if the stamping is begun at the end of the title to be lettered, and finished at the beginning. By this means the workman can tell the relation of the stamp he is using to the work he has previously done; for example in stamping the following: 20 × 42—R. H.—S., begin the stamping with the letter "S", and work back towards the beginning. A center punch is used for marking periods, and a chisel for dashes.

Soldering. Use of Gasoline Torch.—The gasoline torch shown in Fig. 71 is often used by the machinist

when he has soldering jobs to do about the shop. The method of using this torch consists of filling through an opening in the bottom. Air pressure is applied to the interior of the tank by means of the hand pump *A*. The valve *B* is opened and the pump operated until resistance

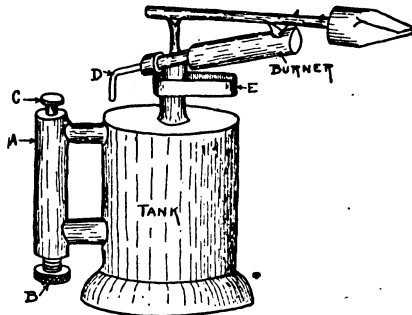

Fig. 71

to the movement of the piston *C* is quite noticeable as the pump is operated. The valve *B* is closed. Valve *D* is now opened slightly and the cup *E* allowed to fill with gasoline; valve *D* is closed, and the gasoline in the cup ignited with a match. This burning gasoline will heat the burner after a few minutes, and when the valve *D* is opened the gasoline coming from the tank will ignite and a flame will issue from the burner, which may be adjusted by manipulating the valve *D*.



Fig. 72

For soldering one needs a soldering copper, Fig. 72, some solder, and some flux. Solder may be either string or bar, but for general machine shop work, bar solder is

more convenient. The flux may be either acid or powdered rosin, acid being more commonly used. The acid must be prepared by saturating it with metallic zinc; this process is often spoken of as "cutting" the acid. Muriatic acid is the base of the solution; into about a pint of this acid, put as much zinc as the acid will dissolve, and the solution is ready for use.

All work to be soldered must be thoroughly cleaned as a preparatory step. The copper must be hot enough to melt the solder freely, and should be kept clean; Fig. 73 shows a device known as a jig; it is a soft red brick with a cup cut in it. This cup is filled with flux, either acid

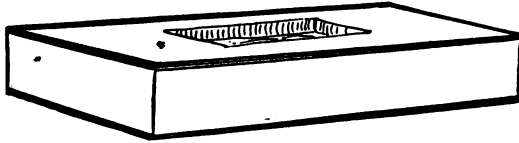

Fig. 73

or rosin, and the copper covered with flux as it is taken from the torch. A cold chisel is used for cutting the cup in the brick. Figure 71 shows the copper mounted on the torch during the heating process; the worker must be sure that the end of the soldering copper has a coat of solder on all faces. The process of applying the solder to the copper is called tinning, and is carried out as follows: heat the copper, dip it into the flux which has been placed in the jig, and rub the bar of solder over the faces *A* and *B*, Fig. 72. Be sure the copper is clean on all faces before starting to tin. As the solder is rubbed on the copper, a certain amount will adhere to the surfaces. If the copper is not tinned, the solder will tend to adhere to the tool instead of the work. Each time the copper is removed from the torch, it may be dipped in the flux, as this tends to produce a free flow of solder when work-

ing. It is not a bad practice to have the cavity in the jig filled with solder and flux, and when the copper is removed from the torch, it is rubbed in this mixture, applying considerable pressure. This treatment keeps the copper, or "bit" as it is sometimes called, well covered with solder.

Suppose the seam at *A*, Fig. 74, is to be soldered, and the copper is properly tinned and heated. We apply

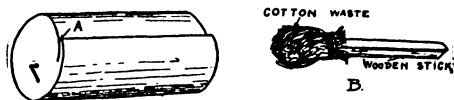

Fig. 74

some flux to the seam by means of a brush, or a swab, made as shown at *B*, Fig. 74. The copper and solder are moved slowly along the seam, holding the solder against the bit, so it is melted. The bit will also heat the piece to be soldered, and the melted solder will run down into the seam. When the solder does not flow freely, the bit should be returned to the torch and heated again.

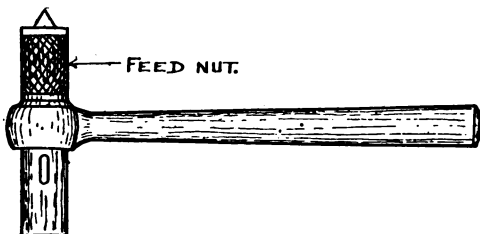

Fig. 75

If powdered rosin is used as a flux instead of acid, it is sprinkled over the surface to be soldered, before applying the solder.

The Ratchet. — In Fig. 75 is illustrated a tool much used at the bench and on the floor in the machine shop;

it is known in the trade as a ratchet; it is used for repair work on jobs requiring drilling, and on new work for drilling in certain places not conveniently reached by a machine. The ratchet being small adapts itself to out of the way locations, and is easily set up for operation.

When working with the ratchet, a ratchet brace must be used in order to support the tool properly; the ratchet brace is sometimes called an "old man." Figure 76

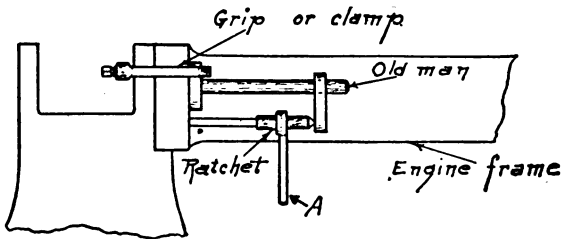

Fig. 76

shows a ratchet set up ready for work on an engine frame. The handle *A* is moved back and forth, this movement turning the drill in only one direction, due to the construction of the ratchet. The feeding of the drill to the work is accomplished by turning the feed nut slightly from time to time, as may be necessary in order to keep the drill cutting. When drilling in steel or wrought iron use a lubricant, but it is not necessary to lubricate the drill when working in brass or cast iron.

QUESTIONS

1. For what purpose are outside, inside and transfer calipers used?
2. Describe the center square and tell its purpose.
3. Describe and illustrate the use of the key seat rule in laying out a keyway.

SUPPLIES AND MISCELLANEOUS TOOLS 59

4. Give and explain the specifications for ordering hack saw blades.
5. Describe the proper method of using a monkey wrench.
6. Give the essential details to be observed in using a mandrel.
7. Why are reamers necessary, in the various machine shop processes?
8. Describe a tap; tell why it is used in the machine shop.
9. Give and explain the specifications to be used when ordering emery cloth.
10. Describe the method of using the wire gages, as applied in machine shop practice.
11. Describe the depth gage and tell the purpose for which it is used.
12. How are calipers classified?
13. Give a brief description of the process of soldering.
14. For what purpose is a ratchet used? Illustrate your explanation.

CHAPTER III

HARDENING AND TEMPERING. MACHINE ADJUSTMENTS. EQUIPMENT. GENERAL TOOLS.

Hardening and Tempering.—Practically all tools which the machinist uses for cutting purposes must be hardened and tempered. These processes consist of changing the structure of the cutting parts of the tools by a very simple treatment which, however, demands considerable skill. In hardening a tool, very severe stresses are set up within the material, and, unless the work is properly handled, it will be spoiled in the hardening process.

The work discussed in this book will deal only with elementary practice in the line of hardening, commonly known as open fire work. Such work is done in the open forge fire, or the gas furnace. The first step when working with the forge is to prepare a clean coal fire. Figure 77 illustrates a modern forge, and the purpose of the various parts is clearly explained by the text in connection with the illustration.

To prepare the fire in a forge, clean out all ash and clinker, place some old oily waste in the fire pot, on this place some chips or shavings, and over all place a shovel full of coal. Ignite the waste with a match, turn on a light blast, and let the fire burn up slowly, putting on coal as it burns, till you have a good fire about ten inches in diameter; build coal up around the outside of this fire, keeping it wet by pouring water on it. The wetting of the coal prevents the fire from spreading and becoming

unnecessarily large, and at the same time produces a supply of coke which is used for feeding the fire. When the smoke has entirely disappeared from the fire it is ready for use.

Let us suppose we are to harden and temper a cold chisel, shown in Fig. 5 A. Tempering is a separate process from hardening, and consists of imparting to the

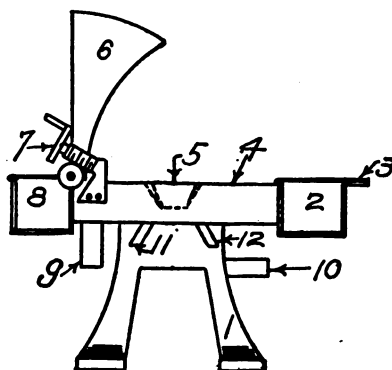

Fig. 77

- | | |
|--|-----------------------|
| 1. Base. | 7. Hood adjustment. |
| 2. Water pan. | 8. Coal pan. |
| 3. Tool rack. | 9. Exhaust connection |
| 4. Hearth. | 10. Blast connection. |
| 5. Fire-pot containing grate and tuyere. | 11. Grate control. |
| 6. Hood. | 12. Draft control. |

tool sufficient toughness to make it serviceable. If we were to take a tool directly after it had been hardened, and attempt to use it for cutting metals it would break almost as soon as it was placed in use. The same temper is not used for all tools, some being made much softer than others; the workman judges the temper of the piece by the colors which appear on the polished surface of the work, after it has been hardened.

We must be certain that the work is hardened before we proceed with tempering, otherwise the time spent in tempering is wasted. Certain temperatures within a piece of steel will produce certain colors on the polished surface of the work, and it is the temperature within the piece that produces the temper. Hence it is evident, we have a definite relation between color of the work, and its temper; the following table is a very useful guide to the beginner when starting practice in hardening:

430° F.	Very light yellow.
460° F.	Straw yellow.
500° F.	Brown yellow.
530° F.	Light purple.
550° F.	Dark purple.
570° F.	Dark blue.

The letter "F" given in connection with each entry in this table, indicates that the Fahrenheit scale is used in measuring the various temperatures. This scale is the most commonly used temperature measuring scale in American and English machine shop practice.

To harden, take the chisel in the tongs, thrust it well into the fire, turn on a medium blast so there is a good free burning fire, and keep turning the tongs so the fire has access to all parts of the chisel while heating. When the chisel is heated to a good bright red, remove it and dip about 2" of the cutting end into a tub of cold water.

Keep the chisel moving up and down about $\frac{1}{4}$ " while the end becomes thoroughly cold. Now quickly remove from the water and with a piece of emery cloth wrapped over a file, rapidly polish one of the faces; after this polishing let the heat which is in the body of the chisel, travel towards the point, judging the temper from the color shown. The color at the cutting point of the chisel should be a brown yellow, ranging through purple and

black on the shank; as soon as the proper color at the point is reached, dip the chisel in the water and cool it completely.

Sometimes one finds that the body of the chisel does not have sufficient heat in it, after the hardening process, to do the tempering; under such circumstances, do not replace the chisel in the fire but hold it *over* the fire, keeping a light blast on, and watching carefully for the color changes. Dip the chisel as soon as the proper color is reached.

As to the temper colors for various tools used by the machinist, the following statements are helpful as a guide. Cutting tools such as diamond points, side tools, milling cutters etc. are drawn to a straw yellow: chisels and any tools which are driven to the work by the use of a hammer may be drawn to a brown yellow; scrapers are drawn to a light yellow, and screw drivers to a light purple.

After tempering take a second cut file and test the work; if the hardening has been properly done, you should be unable to file the article on the cutting surface.

Hardening High Speed Steel. — In modern shop practice "high speed steel" is used extensively. There are a number of brands of this steel on the market; the term "high speed" is applied to them because they can be used at much higher cutting speeds than the ordinary carbon steel tool. The process of hardening this material differs somewhat from the one just described, in connection with the cold chisel. This steel must be heated to a much higher temperature in the forge, and it is not tempered.

Suppose we wish to harden the piece of stock illustrated at *A* Fig. 78; this is a cutting bit and is used in the holder *B*. In the use of high speed steel it is cus-

tomary, if possible, to place a small cutting point in a holder, made of cheap steel, as high speed steel is quite expensive.

To harden this bit, we raise a hot fire in the forge, hollow out a small place with the poker, and lay the bit in it; let it heat till blisters show on the bit which will require a bright yellow heat. Remove from the fire and dip in a bath of cold lard or fish oil, keeping the work in the bath till it is perfectly cold. Remove it from the bath and hold the bit over the fire, heating it till it will

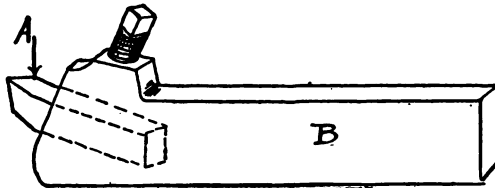

Fig. 78

cause a sharp crack when it is touched with the moistened finger. Lay it aside and let it cool, when it may be ground and put into service.

Annealing. — This process consists of returning the hardened piece to its original state, so it can be worked upon by means of files and cutting tools. Briefly, it is softening the stock again after it has been hardened. To anneal a piece, it is heated to a bright red heat, and buried in a box of hot ashes allowing it to remain thus buried till it is cold. When the piece is removed it will be soft; this treatment is known as ash annealing. Repeated hardening and annealing of a piece of stock changes the structure so it is useless for service as a cutting tool.

Water Anneal. — This treatment is not a very thorough process, but it serves a purpose when one is in a hurry, on many kinds of stock. The method

consists of heating the piece that is to be annealed, to a bright red color, putting it in a dark place, so the color will show plainly, and letting it cool off till no color is noticeable. The article is then cooled in water, and in many cases it will be soft enough to work with cutting tools.

The Gas Furnace. — Figure 79 is an illustration of a gas furnace, such as is used in a great many machine

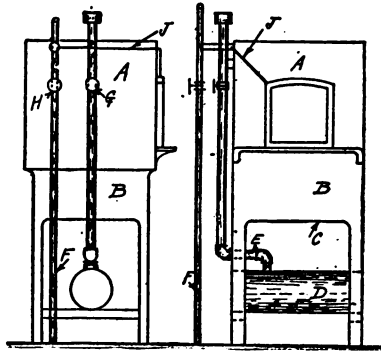

Fig. 79

- | | |
|--|----------------------|
| A. Furnace. | E. Air supply pipe. |
| B. Furnace base. | F. Gas supply pipe. |
| C. Furnace stand. | G. Air supply valve. |
| D. Air reservoir, usually connected
to a blower which must be started be-
fore furnace is placed in service. | H. Gas supply valve. |
| | J. Pilot light line. |

shops. The names of the various parts appear in the notation below the illustration. The use of the gas furnace introduces nothing new in hardening, but a few suggestions on handling the furnace will be helpful to the beginner. To start the furnace, see that the door at the front is open, turn on the air, and let it blow through the furnace. This operation removes any gas which might cause a somewhat violent explosion when one attempts to light the gas. Turn off the air valve, and

light the pilot light, or put a piece of burning paper in the furnace; turn the gas and air on slowly, keeping the face away from the front of the furnace. As the gas ignites there may be a slight report, but this will do no harm. Adjust the air and gas valves, increasing or diminishing the amount entering the furnace, till you have a bright red flame, when the heating of tools may be started. The gas furnace is much more convenient and accurate than the forge, and work can be treated in it with much less danger of loss.

Adjustment of Machinery. — One of the things which the young mechanic should learn very early in his career is the adjustment of machinery. A machine which is not properly adjusted cannot produce work as rapidly nor as accurately as one in proper adjustment. These adjustments will require the workman to handle a great many small parts, and the learner should be acquainted with the proper terms used in describing these parts; most of these terms are technical, and sound quite unlike the language of everyday life with which the beginner is acquainted.

In all machines having any revolving parts there are introduced spindles and shafts; a shaft is a mechanical element used to carry some revolving machine part, such as a pulley or a gear; a spindle is a revolving mechanical element which carries a cutting tool, or a piece of work while being operated upon. A small shaft, supporting a light revolving element is also spoken of as a spindle. Spindles and shafts are carried in boxes as shown in Fig. 80.

As a box or spindle wears, there must be some means of adjustment to compensate for the wear, and in Fig. 80 we have the simplest type of design in use for such adjustment. The box shown is known as a split box, and at *A* is shown a "shim"; as wear develops the cap is

removed, and a small amount filed from the shim, thus allowing the box to close more tightly on the shaft, but not tight enough to prevent the shaft from turning. The binding bolts are always set up solidly after filing a shim; this is a job that should be done very carefully, as the removal of too much stock from the shim will cause the box to grip the shaft too tightly; the shaft will expand due to the heat generated by friction, and the box will soon be damaged. That part of a shaft or

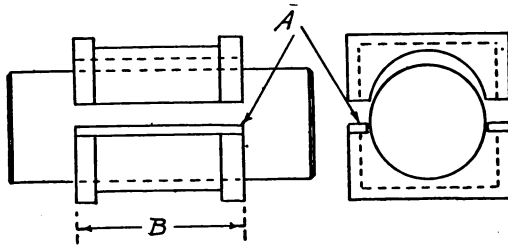

Fig. 80

Portion of shaft *B* resting in box is known as the "journal." This portion is sometimes terminated with a shoulder at each end of the journal.

spindle, which rests in a box is known as a **journal**. Very often the journal is somewhat larger than other parts of a shaft, though in many cases there is no change of diameter at this point. The part of a box which bears against the journal, is known as a bearing; bearings are made of cast iron, bronze, hardened steel and "babbitt metal."

In many designs the shim, used between the upper and lower halves of a box, is made up of a series of very thin pieces of metal; mica, and paper are also used for this purpose. These shims are known as leaf shims, and adjustment of the box is obtained by removing one of the thin sheets, and replacing the cap, then setting up the binding bolts.

The Check Nut. — This is a binding element, with which the machinist often comes in contact. Figure 81

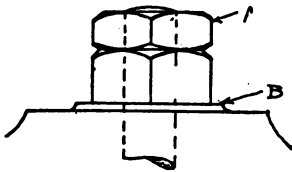

Fig. 81

shows the device, the purpose of which is to maintain the jamb nut in the proper position. Any part of a machine which is held in place by means of bolts and nuts is apt to become loose especially if the parts are subject

to some vibration. To prevent this the jamb nut is used with a check nut as shown; to adjust a jamb and

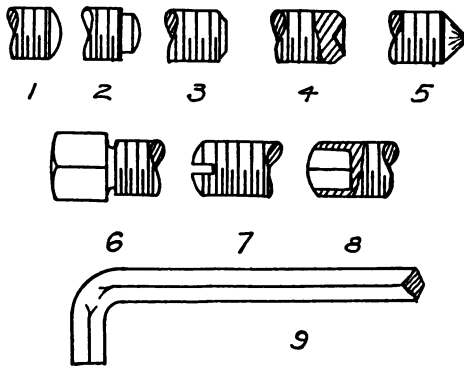

Fig. 82

1. Round point set screw.
2. Pivot point set screw.
3. Flat point set screw.
4. Cup point set screw.
5. Cone point set screw.
6. Neck style of head.
7. Slotted headless set screw.
8. Hollow headless set screw.
9. Wrench for hollow headless screw.

All types of points may be obtained with any style head.

check nut properly, first screw the jamb nut down solidly, hold it with a wrench, and then screw the check

nut down solidly, thus making a secure fastening. In design practice it is customary to make the check nut thinner than the jamb nut, and champher it slightly on both faces as shown at A, Fig. 81. A check nut is commonly used on all bolts that hold bearing caps in place, if the shaft is much over three or four inches in diameter.

Set screws are used a great deal to hold light pulleys to the shaft; they are also used a great deal for holding pulleys that are keyed to a shaft, to prevent the pulley

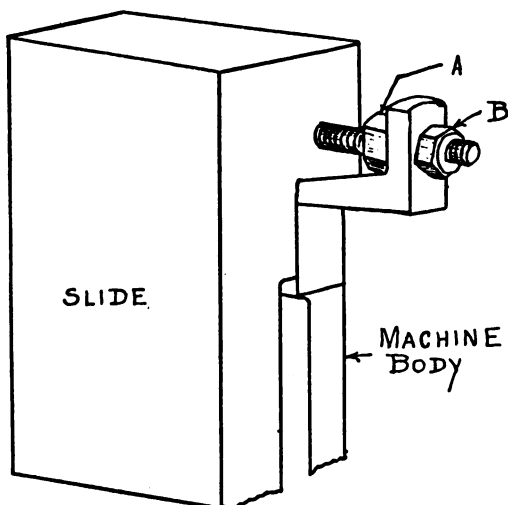

Fig. 83

from moving endwise on the shaft. In all cases where the set screw is exposed, the headless variety as shown at #8, Fig. 82, should be used; this eliminates the danger of an operator being caught by the protruding head of the screw, and injured. The various kinds of set screws are shown in Fig. 82.

The gib, see Fig. 83, is used a great deal to take up wear between flat or plane surfaces; the application of

this adjustment is shown in Fig. 83 where the method of operation is clearly indicated; the check nut *A* is slacked off and the jamb nut *B* is set up in order to take up any wear, while the reverse of this operation slacks the gib off, giving more play. The particular design illustrated

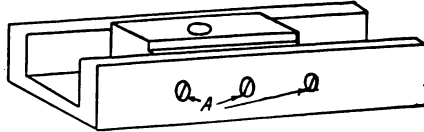

Fig. 84

Cone or pivot point headless set screws used in setting up for adjustment as indicated at *A*.

in Fig. 83 is known as a taper gib; another type shown in Fig. 84 is known as a flat gib, and the adjustment is effected by simply tightening or slacking off the headless set screws shown at *A*.

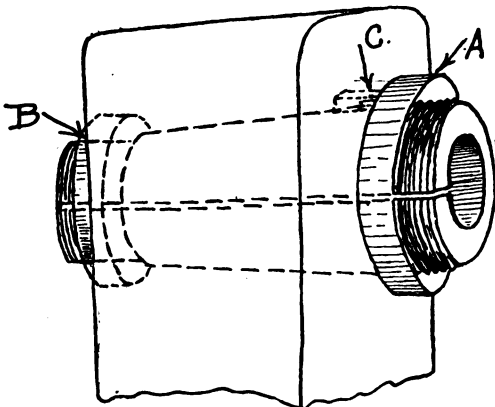

Fig. 85

A type of box adjustment much used by machine tool builders is the tapered shell, illustrated in Fig. 85 where the method of adjustment is illustrated; the part of the

machine in which the box rests, known as the seat, is taper bored, and the shell is turned or ground on the outside surface to fit this seat; a slot is cut in the shell (or box) so that by moving this box in the seat, by means of the nuts *A* and *B* we may open or close it. Forcing the box in will close the box; moving it out of the hole will open it. In construction the seat is usually fitted with a small keyway into which a "pin" key fits, this key being fast in the box. Such a feature of design prevents the box from turning when stress is placed on the adjusting nuts.

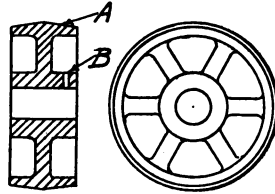

Fig. 86

Crown shown at *A*.
Oil hole shown at *B*.

Minor Machine Parts. — In connection with a shaft in machine design, we must in many cases use a pulley; the practical form of this device is shown in Fig. 86. A pulley will not carry a belt satisfactorily unless it is "crowned," that is, larger in diameter at the center than on the edges. In turning this pulley a taper of $\frac{3}{4}$ " per foot is quite satisfactory for general work. The application of the pulley in practice often demands using it with another one arranged beside it; one pulley is fastened to the shaft by means of a key, while the other runs loose on the shaft; such an arrangement as described must be used when a belt is used to drive a machine which must be frequently started and stopped. All machine tools must meet this requirement, so we find the tight and loose pulley arrangement much used in the machine shop. The loose pulley must always be fitted with an oil hole as indicated in the illustration.

Bolts and nuts are used a great deal about the machine shop for fastening various parts of the equipment together, and for clamping work on the machines; the

machinist must be acquainted with the proportions of the standard bolt, and in Fig. 87 these are shown. Note that both rough and finished sizes are given for the various dimensions. The rough sizes indicate the dimensions for a forged or roughly machined bolt and nut, while the finished sizes give dimensions for accurately finished bolts. For clamping purposes the machinist commonly uses bolts having specially sized heads which fit the slots in the various machine parts to which work is clamped when operating on it; a standard nut is used on these clamp bolts. Whenever a bolt is used for clamping work, a washer should be used between the face of the nut and the work or clamp as shown in Fig. 87. This washer enables us to draw the bolt up solidly without causing a clamp to twist, and also gives a good bearing

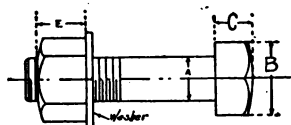

Fig. 87

- $B = 1\frac{1}{2}A + \frac{1}{8}"$ for rough bolt heads in square and hexagonal form.
 $B = 1\frac{1}{2}A + \frac{1}{16}"$ for finished bolt heads in square and hexagonal form.
 $C = \frac{1}{2}B$ for rough bolt heads in square and hexagonal forms.
 $C = A - \frac{1}{8}"$ for finished bolt heads in square and hexagonal forms.
 $E = A$ for rough nuts in square and hexagonal forms.
 $E = A - \frac{1}{16}"$ for finished nuts in square and hexagonal forms.
 Other dimensions of nuts same as for bolt heads.

for the nut; the diameter of a washer is usually one and one eighth times the distance across corners of the nut with which it is used.

Keys are used to fasten gears and pulleys to shafting in situations where considerable stress is to be transmitted; the most common type is the square key, illustrated in Fig. 88. When this device is fitted so that it is free to slide in the slot in the shaft, as well as in the pulley or gear it is spoken of as a key; if it is driven

solidly in the shaft, but the portion extending outside of the shaft filed slightly so it slides freely in the keyway of a pulley or gear, it is known as a "feather key." As a

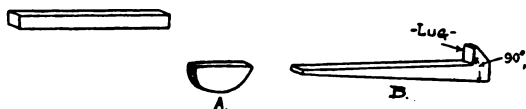

Fig. 88

general rule a square key is made up so its width is equal to one fourth the diameter of the shaft; the thickness is made the same as the width. In design practice these sizes are departed from somewhat, but as a guide the above mentioned proportions are serviceable.

A type of key which is very serviceable, because it will carry a heavy stress without damage, is shown in Fig. 88 A. This key is known as the Woodruff key; it is semi-circular in form and the seat, as the part of the shaft cut away to fit the key is called, is cut with a special cutter; table IV presents the various sizes of this key as related to the designating numbers.

Taper keys are often used in machine construction, and an illustration of a key is shown in Fig. 88 B; notice that the angle forming the taper is placed on one face only, sides of key are parallel; keys of this kind are planed to a taper of $\frac{1}{8}$ " per foot, or $\frac{6}{10}$ of a degree. Taper keys are not always made with the lug, though it is commonly best to have the key so made. In planing these keyways, the seat in the shaft is planed as for a common square key, and the "taper" of the keyway formed entirely in the hub. The deepest portion of the keyway in the hub should be the same depth as for an ordinary square key.

Taper pins are used a great deal in machine tool construction; whenever you are taking a machine down be

sure to notice whether or not one end of the pin you are attempting to drive out is larger than the other. If it is tapered you should drive from the small end. Again if you are fitting a pin to a hole, be sure you find out whether or not it is to be a taper pin. The standard taper for these small pins is $\frac{1}{4}$ " per ft. as used by some of the large machine tool firms.

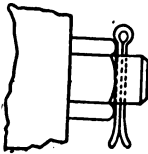

Fig. 90

Cotter pins are used to hold parts in certain relation, where no great stress is applied to the cotter. In Fig. 90 we see a cotter, and also an illustration of its use; table V gives the proportions of these pins.

Figure 91 shows a number of types of screws used in machine work, and proportions of the heads. The young

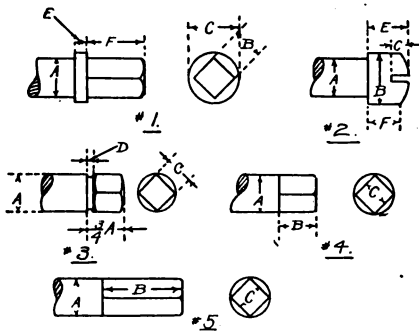

Fig. 91

- #1. Collar screw.
 $B = A$; $C = 1\frac{1}{2}A$; $E = \frac{1}{2}A$; $F = 1\frac{1}{2}A$.
- #2. Fillister head cap screw.
 $B = 1\frac{1}{2}A$; $C = \frac{3}{4}A$; $E = \frac{3}{4}A$; $F = \frac{1}{2}A$.
- #3. Neck type of set screw head; the full head is of the same proportions.
 $C = A$; $D = \frac{1}{2}A$.
- #4. Solid headless set screw.
 $B = A$; $C = \frac{3}{4}A$.
- #5. Squared rod ends.
 $B = 2A$; $C = \frac{3}{4}A$.

worker should study these drawings with care, in order that he may become familiar with the specific name for each type of screw shown. All square, round, button, and filister head screws, as well as collar screws, are designated in length by measurement *under* the head.

Machine screws are often used for fastening the lighter parts of machinery together, and the varieties commonly met are shown in Fig. 92. Machine screws are more often designated by number than by diameter, though the suggested standard of the American Society of Mechanical Engineers designates the outside diameter of

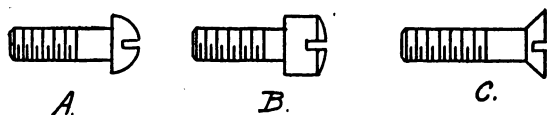

Fig. 92

Types of machine screws.

A. Round Head. B. Filister Head. C. Flat head.

the screw in decimal fractions of an inch; the table VI presents the gage standard by number, American Screw Co.'s specified diameter in decimal fractions of an inch for respective numbers, threads per inch on the screw, number or letter size of tap drill, and diameter of tap drill in thousandths of an inch, for drilling holes to tap for various size screws.

Since, in fitting small screws, we must use a tap drill to drill the hole, the above mentioned table will be very serviceable to the machinist; in order to use it intelligently however the workman should understand the twist drill gage illustrated in Fig. 57. This gage is used to determine the size of a drill by simply inserting the drill in the hole; the hole into which the drill fits closely indicates the size of the drill by number. Table VII gives the decimal equivalents for the various numbers of the twist drill gage.

For medium sized drills, that is, those sizes between the small drills designated by numbers, and those commonly indicated by fractions of an inch a letter system of designating drills is used; Table VIII presents the decimal equivalents of the various letter sizes commonly used.

Belting. — A great deal of belting is used in the machine shop; belting is designated by its ply and width; most of the belting used is single ply, that is, but one thickness of hide is used in the making. Two ply and three ply belting is used to some extent on large sizes where a great deal of power must be transmitted. Two and three ply belt should not be used on small pulleys, as such use will cause the different layers to separate and the belt will be ruined.

For all small belting work the joining of the two ends is effected by lacing with a strip of light leather, known as lace leather; the length of this lacing will be from seven to ten times the width of the belt.

To place a belt stretch a string tightly over the pulleys to be connected by the belt; draw this string as tightly as you can; remove it, and cut your belt one sixteenth of an inch shorter than the string for each foot of length of belt required. Suppose, for the purpose of illustration that we found our string to be 15 ft. long, then we would cut the belt $\frac{1}{16}$ " shorter than the length of the string. This reduction in length is made to allow for the stretch of the belt.

When a belt is put on a pulley, the smooth side should be run next to the pulley face. Having cut the belt to the required length, take a try square and laying it along the side of the belt test the ends with the blade. If these ends are not square, trim them carefully till they are square, then with a belt punch, place holes about $\frac{1}{2}$ " from the end of the belt, and about $\frac{1}{2}$ " apart as shown in Fig.

93. Now place the belt over the shafts to be connected, so that after lacing, the smooth side will run next to the pulley, and put in the lacing as shown in Fig. 93. Start lacing at the center holes as shown at *A*, and seeing that

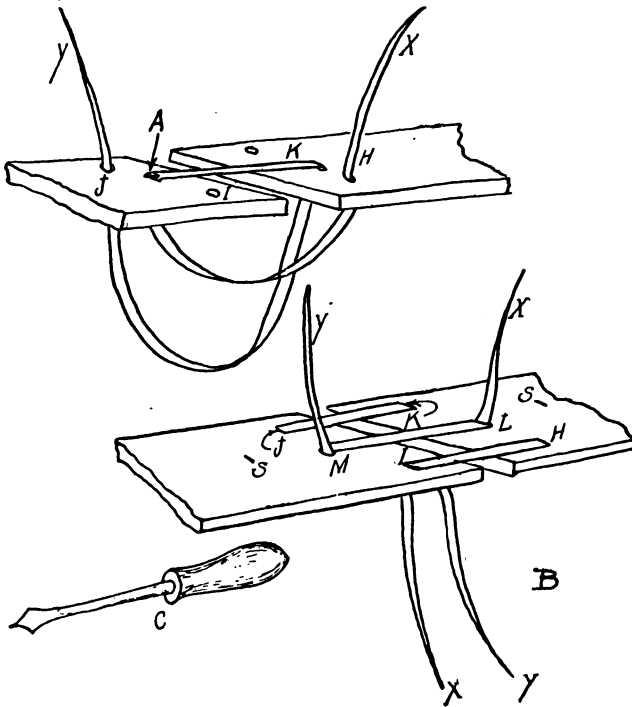

Fig. 93

the strands of the lacing as they appear on the smooth face of the belt are parallel to the length of the belt; let the crossing of the strands appear on the outside of the belt. Next bring end *X* of belt lace up through hole *H*, and pass it down through hole *I*; then pass end of lace *Y* up through hole *J* and down through hole *K*. Draw all

lacing up tightly; the belt now appears as in *B*, Fig. 93. Pass end *X* of belt up through hole *H*, and down through hole *I* again, doubling the outside strand of the lacing, and do the same thing with end *Y* of lacing, passing through holes *J* and *K*. Bring end of lacing *X* up through hole *L* as shown at *B*, Fig. 93, and end of lacing *Y* up through hole *M*. Now using the belt awl shown at *C*, punch two small slits in the belt as shown at *S*, and push the ends of the lacing through these. Take a sharp knife and cut a notch in the ends of the lacing, then cut the lace off so an end about $\frac{1}{2}$ " long is left; twist this end around so it will not pull out of the slots, and the belt may be placed on the pulleys.

Belts may be kept in good condition, by wiping them once a week, with a piece of waste, moistened with neats-foot oil.

Materials Used in the Machine Shop. — The materials most commonly used in the machine shop are cast iron, open hearth machinery steel, crucible machinery steel, tool steel, brass, and babbitt metal. We will not study the metallurgy of these metals but it is necessary that the young workman know something of their practical characteristics. Castings are made from pig iron after it has been melted in a cupola furnace, and pig iron is extracted from iron ore by a process of heating in a blast furnace; a blast furnace is really a large cupola.

The castings which come to the machine shop are made in the foundry by pouring the melted iron from the cupola into a mold, which has been made by embedding a pattern in sand. The pattern maker's trade is the art of making the patterns, either from wood or metal. The moulder's trade is the art of producing the casting mentioned, while the machinist's work consists of finishing and fitting these castings, and assembling all necessary parts to make an operating machine.

The casting usually comes to the machine shop properly pickled, rattled or sand blasted, so that the loose sand and hardest scale has been removed. This treatment of castings by the foundry is necessary because the hard scale thus removed is very injurious to cutting tools if a casting is sent to the machine shop, without the treatment mentioned. The first job done on the casting after it reaches the shop is "snagging"; this is commonly looked after by laborers, or apprentices, during the first few weeks of apprenticeship. This work consists of chipping off fins, burrs, and irregular spots on the surface of the casting; after this work, the casting goes to the machinist.

Open hearth machine steel is produced by a process of melting, casting and rolling at the steel mill. The stock is melted in large furnaces, called open hearth furnaces, hence the name of the material. It comes to the machine shop in bars or plates, and is used for bolts, screws, shafts, washers and similar work. It is comparatively strong, easily worked, and can be attractively finished at small cost.

Crucible machine steel is a higher grade, stronger and more expensive stock than open hearth machine steel. It is produced by a method modeled after that followed in producing crucible tool steel, hence the name. It is used in machine tools for spindles, gear shafts, gearing, and all work where stiffness and unusual strength are demanded. It does not cut as freely as open hearth steel, hence the same cutting speeds cannot be used with this stock as when working softer steel. For cutting speeds see table IX.

Tool steel is the stock from which the tools used by the machinist are made. Each manufacturer has a number of different grades of steel, suited to different classes of work. The same grade of steel should not be used for

making a cold chisel, as is used for making a milling cutter. Cold chisels, diamond points and similar tools are made from a cheaper class of stock, than can be used for tools having an intricate cutting edge.

Any of the reputable steel manufacturers can supply a grade of steel from which the skilled workman can make tools of all kinds for various classes of work. Open hearth and crucible machine steel cannot be hardened and tempered by the simple process of heating and cooling, but tool steel can be so treated.

High speed steel is a kind of tool steel much used in modern shop practice. The tool steel previously mentioned is an alloy of carbon and iron only; high speed steel is an alloy of other materials than carbon and iron, such as tungsten and manganese. This steel will operate under a much higher cutting speed, than will carbon steel; it is therefore a very desirable material from the standpoint of economic production.

An alloy has been put on the market recently which is known by the trade name of *stellite*. This material is used for cutting tools; it cannot be forged, but is ground by the workman to the desired shape. It is very serviceable for rapid cutting especially on roughing cuts. The material is furnished to the trade in small bars, and

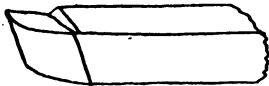

Fig. 94

should not be ground to form sharp angles. Tools, in this material, should be of a rounded form; figure 94 shows a very satisfactory grinding of a stellite

tool. The apprentice should write the Crucible Steel Co. of America, New York City, or the Halcomb Steel Co., Philadelphia, Pa., for a tool steel catalog.

Brass is a soft alloy much used in the shop in places where the part being made is subject to corrosion, when in use. Brass is sometimes used for bearings; brass is composed of copper, tin, and zinc.

Babbitt metal is a comparatively soft alloy, composed of tin, copper, and antimony; it is easily melted in a forge fire, and may be cast in wooden molds. The ease with which babbitt metal is worked, both in casting and machining, makes this alloy both convenient and economical. The machine designer uses babbitt a great deal in bearings, where unusually high stresses are not met, and where slight displacement of parts due to wear, will not seriously effect the usefulness of the machine.

Miscellaneous Machinery.

— When the young worker enters the machine shop he will find a number of general purpose tools. Since these are often used the equipment may well be studied at the present time.

The grindstone is shown in Fig. 95 with each part properly named; in Fig. 96 the method of mounting a grindstone on a square shaft is shown. The nuts on the sides of the stone are indicated at *B* and *C*, Fig. 96, and these should be solidly tightened up so that there may be no tendency for the wedges to loosen; in driving the wedges do not set them up too hard as the stone may be cracked in so doing.

Grindstones are commonly graded by the grit and hardness; grits are classified as fine, medium and coarse, while the hardness is classified as hard, medium and soft.

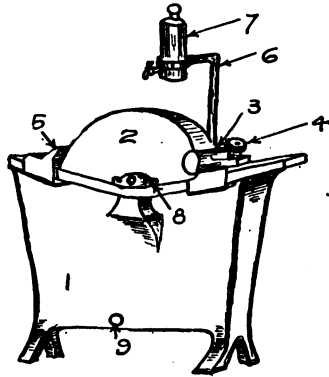

Fig. 95

1. Trough.
2. Grindstone.
3. Truing device.
4. Truing device handwheel.
5. Tool rest.
6. Water reservoir stand.
7. Water reservoir.
8. Bearings.
9. Drain plug.

In ordering a grindstone one should state the diameter of stone, width of face, size of hole, grit, and degree of hardness. Huron and New Brunswick stones are much used in the United States. Both of these stones are light blue in color.

For grinding machinist's tools a grindstone should run at a surface speed of 800 to 1000 feet per minute. After a grindstone has been mounted on the shaft and placed

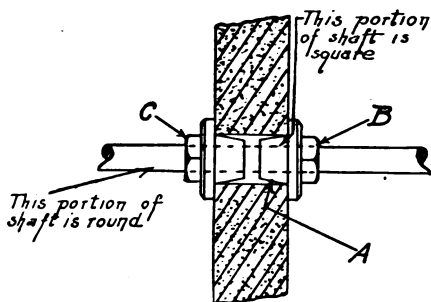

Fig. 96

A indicates wooden wedges driven between the shaft and stone, so it may be set approximately true on the shaft when mounting.

in the bearings, it must be trued up; this job may be done by using a piece of pipe supported on the tool rest, holding it very firmly with the hands, and rolling the pipe slowly back and forth along the rest. The stone should be kept wet during this operation.

A much better way to true a grindstone is to use a truing device such as shown in Fig. 95 where we see this attachment set up ready for use. When truing a stone, water should be run on the stone surface and the cutting roll forced against the stone by means of the hand-wheel 4, Fig. 95, until the roll cuts all around the circumference, when the use of the truing device should be discontinued.

The wet tool grinder, shown in Fig. 97, has displaced

the grindstone in a great many shops. The cutting wheel used on the wet tool grinder is an abrasive wheel, either the carborundum or alundum variety; a very good wheel for general tool work is an alundum 36 P. or equivalent. (See chapter on grinding for information on the grading of wheels.) The tool grinder is always equipped with some means of keeping water on the wheel. In the particular machine illustrated the pump at 4, Fig. 97, is connected on one side to the tank in the base of the machine, and the other side delivers the water to the wheel. The water returns to the tank after passing over the wheel and is used repeatedly.

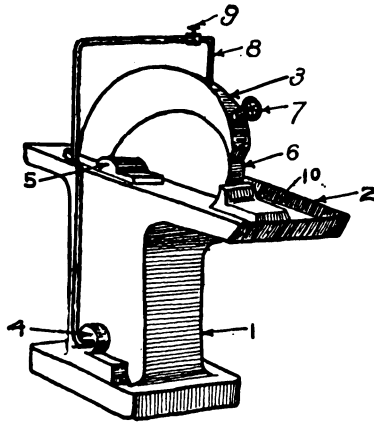

Fig. 97

1. Base.
2. Pan.
3. Hood.
4. Pump.
5. Bearing.
6. Wheel.
7. Truing Device.
8. Water supply line.
9. Water supply valve.
10. Tool rest.

The surface speed of a wheel for this class of work should be about 4500 feet per minute. In truing an

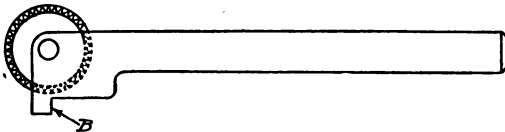

Fig. 98

abrasive wheel the device shown in Fig. 98 is used. This tool is known as an emery wheel dresser, and in using it

the tool rest 10, Fig. 97, is moved back, fastened solidly, and lip *B* of dresser hooked over it, in order to bring pressure against the wheel.

The tool must be held very steadily, and not allowed to shake when in use, otherwise the surface of the wheel will be irregular, or as the machinist would say, "out of true."

On certain designs of wet tool grinders a truing device is mounted at 7, Fig. 97, which is operated in the same manner as the truing device described in connection with the grindstone.

The term "surface speed" may be discussed at this time, as it is mentioned in describing the grindstone, as well as the tool grinder. Let us suppose that the wheel were rolling on a flat surface instead of revolving on a shaft; as each point of the surface of the wheel comes in contact with the surface on which it is rolling the wheel will move forward in the same manner that a locomotive moves forward when the driving wheel revolves.

If, after the wheel has been revolving for one minute, it is five thousand feet away from the point where it started to roll, the surface speed of the wheel is said to be 5000 ft. per minute. If it is 1000 feet from the starting point, the surface speed is 1000 ft. per minute.

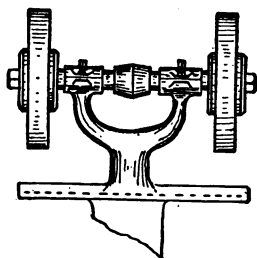

Fig. 99

The polishing stand is shown in Fig. 99. This is really a small tool grinder designed to run at very high speeds.

It is used for grinding small tools such as drills, taps, thread tools, etc. It is also used for polishing, hence the name. The grinding wheel used is similar to the one used on the wet tool grinder, only it is smaller and no water is used. The proper method of mounting an abrasive wheel is shown in Fig. 100. There is danger of a grinding wheel bursting, hence the necessity for careful mounting. The proportions of wheel flanges given in connection with the figure are those suggested by the Pennsylvania Department of Labor and Industry.

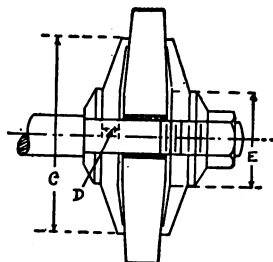

Fig. 100

Diameter of wheel	C	E	D
6"	2"	1"	$\frac{1}{2}$ "
8"	3"	2"	$\frac{1}{2}$ "
10"	3 $\frac{1}{2}$ "	2 $\frac{1}{2}$ "	$\frac{1}{2}$ "
12"	4"	2 $\frac{1}{2}$ "	$\frac{1}{2}$ "
14"	4 $\frac{1}{2}$ "	3"	$\frac{1}{2}$ "
16"	5 $\frac{1}{2}$ "	3 $\frac{1}{2}$ "	$\frac{1}{2}$ "
18"	6"	4"	$\frac{1}{2}$ "
20"	7"	4 $\frac{1}{2}$ "	$\frac{1}{2}$ "
24"	8"	5 $\frac{1}{2}$ "	$\frac{1}{2}$ "
28"	10"	7"	$\frac{1}{2}$ "

Polishing wheels are commonly made of wood, surfaced in leather, this leather being held in place by means of wooden pegs, such as shoemakers use. The surface of the leather is coated with emery; such a polishing wheel is illustrated

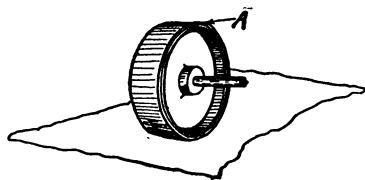

Fig. 101

in Fig. 101. It is built up of three layers of white pine so arranged that the grains of the different layers

cross each other; these layers are glued together, and reënforced with bolts. The leather used should be a good grade of single ply, oak tanned belting, cut to the width of the wheel. The ends of the leather should be "scarfed," so a smooth joint is made as indicated at *A*.

In attaching the leather to the wheel, wet it thoroughly, place the smooth side against the wheel surface, and begin pegging it to the wheel at a point midway of the length of the leather strip, making the pegging of the ends the last of the work. After attaching the leather face, the wheel is mounted on a mandrel in an engine lathe, and with a very sharp tool it is turned to a true surface.

The final step in preparation is the coating of the face with emery, which is illustrated in Fig. 101. For the best results the wheel should be warm and both glue and emery should be hot. Sprinkle the emery evenly over the surface of a sheet of heavy paper, or cloth as shown in the figure, coat the leather face with hot glue, and roll it in the emery, applying considerable pressure.

When the whole circumference of the wheel is evenly coated, it may be laid in a warm place to dry, for about ten hours. The wheel should then be given a second coat of emery, by using hot glue and rolling as described, allowed to dry ten hours more, then given a third coat and allowed to dry twenty-four hours, when it is ready for use. This treatment produces a wheel which will give excellent service, and is possessed of very free cutting qualities.

A workman having charge of the polishing in a large plant has many polishing wheels, coated with the different grades of emery from #60 to flour. He also has some wheels with no emery on the leather face, which are used for producing very high finish. These wheels are known as buff wheels, or simply "buffs."

Figure 102 illustrates a rag wheel, which is used for polishing irregular surfaces; crocus is rubbed on the face while the wheel is running, and acts as a polishing agent when the work is pressed against the wheel. The surface speed of a rag wheel should be about seven thousand feet per minute. The work must be roughed down with polishing wheels before the rag wheel is used. Leather faced polishing wheels may be run at a surface speed of from 5000 to 7000 ft. per minute.

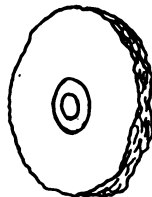

Fig. 102

Figure 103 illustrates a mandrel press, a small machine tool used for forcing mandrels in and out of work; the illustration is self-explanatory. Always put

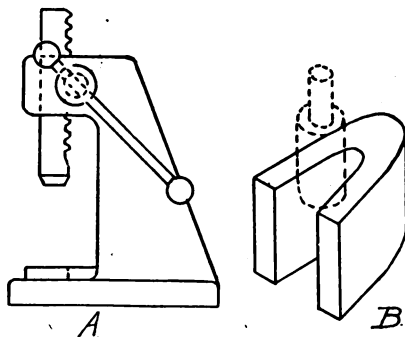

Fig. 103

A is mandrel press.

B is a mandrel block for driving a mandrel in or out of the work.

a little oil on a mandrel, wiping it over the surface with the hand, before forcing it into the work.

The soda kettle illustrated in Fig. 104 is used to wash work when it comes from the machines. The water is heated by means of steam passing into the kettle through the pipes shown; at *A* is shown the steam inlet pipe connection, *B* the steam outlet pipe connection, and at *C* is

a test pipe. After opening the valves on *A* and *B* the valve *V* may be opened, and when steam comes from the pipe *C* we know that we have a free passage of steam in the heating coils of the kettle, and after the water in the kettle has once been brought to the boiling point the valve on *B* may be closed.

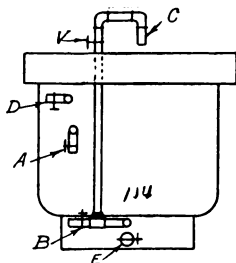

Fig. 104

The heat from the steam in the pipes is usually sufficient to keep the mixture in the soda kettle hot if the valve on *A* is left open, and valve *V* is opened and a small

amount of steam allowed to blow through each time the soda kettle is used.

In preparing the mixture to be used in the soda kettle about a half pound of soda to a gallon of water may be used. Fill the kettle about three fourths full, with this mixture, and add a quart of soft soap or two bars of sliced hard soap. Bring the mixture to a boil and let it boil ten minutes, when the bath is ready for use.

Figure 105 shows a dipping bucket used in connection with the soda kettle. The work is placed in this kettle and worked freely around in the bath; when the work is removed it dries of itself, due to the heat of the bath. At *D*, Fig. 104, is a pipe connection for filling the kettle with water, and at *E* is a connection for drawing it. All kettles are not connected as described, but the arrangement presented is typical of many installations.



Fig. 105

QUESTIONS

1. Give a brief description of the process of hardening and tempering steel, telling why this process is necessary.
2. Describe the building of a fire in the forge.
3. What is meant by "high speed steel"?
4. Describe the process of annealing.
5. Define a shaft; box; journal.
6. For what purpose is a check nut used? Describe the proper method of setting a check nut.
7. How, and for what purpose is a gib used?
8. What is the reason for "crowning" a pulley?
9. For what purpose, and in what manner are keys used in machine construction?
10. Give and explain the meaning of the various "plies" of belting.
11. Give a brief description of a casting, as it comes to the machine shop.
12. Briefly describe the various kinds of steel used by the machinist.
13. Give a brief description of brass, and babbitt metal, and tell where these metals are commonly used in machine design practice.
14. Give the specifications for grading grindstones; explain your statements.
15. Give a brief description of the wet tool grinder, and the wheels used with this machine.
16. Explain the meaning of the term "surface speed."
17. Describe the method of coating a polishing wheel.

CHAPTER IV

LATHE TOOLS

The Lathe, and Lathe Equipment. — The young mechanic should become familiar with the various kinds of tools used at the lathe, so that he recognizes them immediately upon seeing them. The first tool shown is known as a diamond point, Fig. 106. The various angles given in the illustration have been found serviceable in

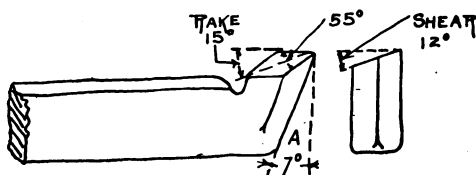

Fig. 106

practice. This tool is used not only on the lathe but on the planer as well. The essential difference between a lathe and a planer diamond point is in the clearance at

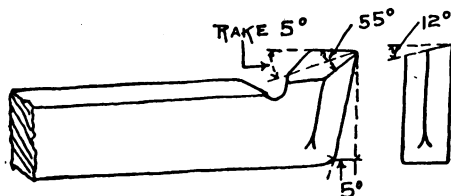

Fig. 107

A, which is the angle for the lathe being illustrated in the first Fig. 106, while that for the planer is given in Fig. 107.

Figure 108 illustrates a brass tool, which is used for turning and facing brass. The flat top and very marked clearance as shown at *A* makes this tool very serviceable on the class of work mentioned. Any tool with a

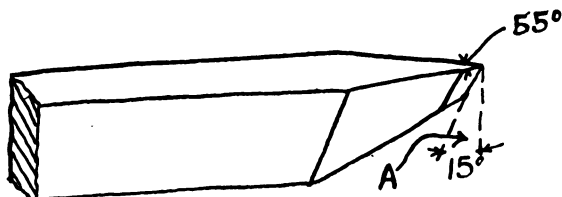

Fig. 108

Brass tool. Round or flatten point slightly before using tool for turning.

marked rake or shear will not work well on brass, because the material is tough and the tool tends to "bite," often spoiling the job. This tool is also available for turning long slender shafts, as it can be set higher above the center than the diamond point, and thus has less tendency to spring the work.

Figure 109 illustrates what is sometimes known as a hog-nose tool. The angles for grinding in clearance rake

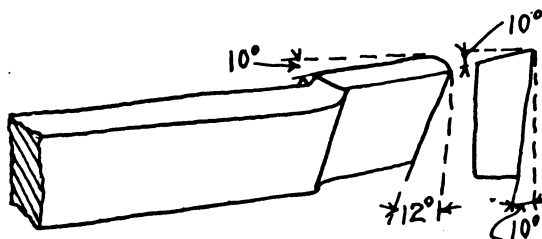

Fig. 109

and shear are given in the illustration. In using this tool for turning long slender shafts, the workman should be careful that the tool does not have too much of a bearing surface on the work, as it will cause the work to chatter,

leaving a number of small marks which do considerable damage on certain jobs. In using this tool on such work it should be raised considerably above the center.

Raising the tool above the center is not necessary as a general rule, when working in brass.

Figure 110 illustrates a right hand offset cutting off tool, which is used for parting work close to the face-

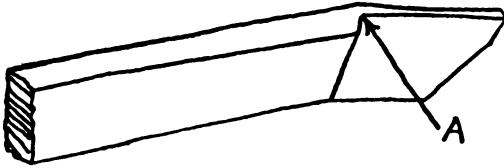

Fig. 110

plate or chuck. Note particularly the bend at *A* in this tool, which is designated as a right hand tool. If the cutting point is bent as shown in Fig. 111, the tool is

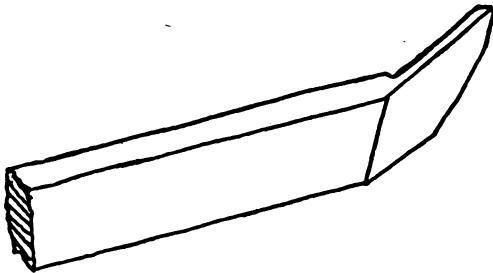

Fig. 111

known as a left hand offset cutting off tool. These tools should always be ground with a clearance on the side faces, as well as an end clearance.

The tool shown in Fig. 112 is a straight cutting off tool. The clearance on this should be approximately as shown in the illustration, and the same is suggested for the offset cutting off tool.

Figure 113 is a right hand offset threading tool. This tool is used for cutting threads on pieces where the thread

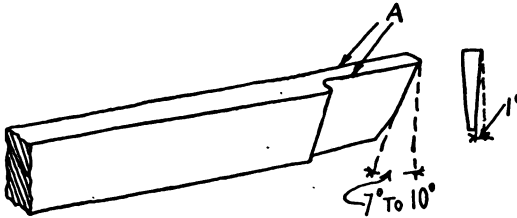

Fig. 112
 $\frac{1}{8}$ " per inch side clearance at A.

must run close under the shoulder. The part A is ground to fit the thread gage for the particular thread which is

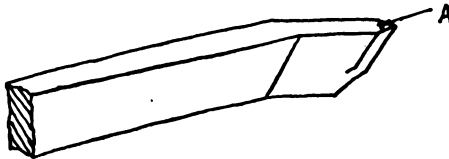

Fig. 113
 A equals angle of thread to be cut.

to be formed, namely U. S. standard, Whitworth, Acme, etc. The details of the method of setting this tool when

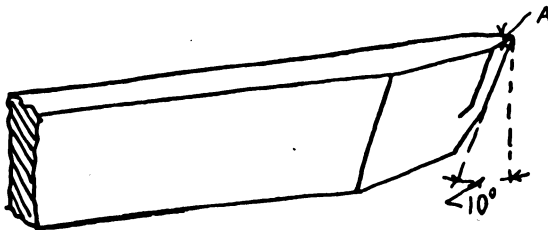

Fig. 114
 A equals angle of thread to be cut.

cutting threads, will be taken up in connection with lathe operation.

Figure 114 illustrates a straight threading tool, which is ground in the manner described for the offset tool.

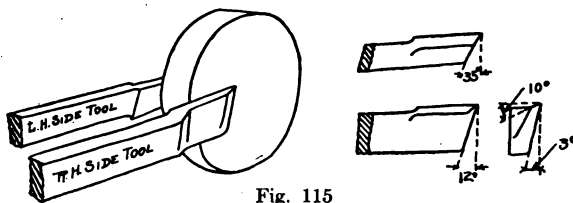

Fig. 115

This is used for cutting threads when it is not necessary to run them close under a shoulder.

Figure 115 illustrates a right hand side tool. The illustration shows the tool applied to a piece of work,

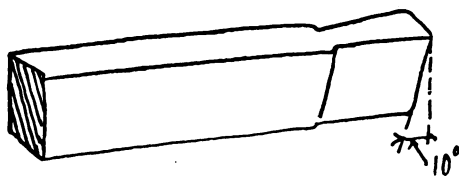

Fig. 116

and the operation is known as facing-up. The angles given will be found serviceable when grinding this tool.

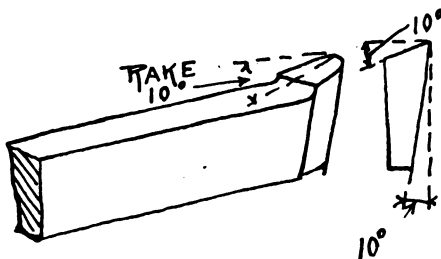

Fig. 117

The right hand offset side tool is used for the same purpose as the straight side tool, but on jobs that require the

facing operation to be carried out on a shoulder which is close to the driving dog.

Figure 116 illustrates a shovel nose tool. It is used for finishing work which permits a very heavy feed. This is

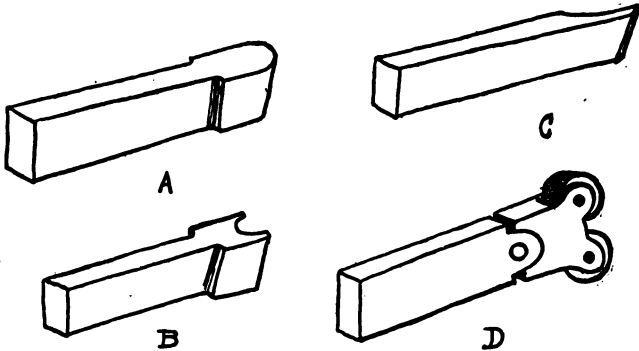

Fig. 118

commonly used in working cast iron on both the lathe and planer. The clearance angle for use on the lathe is given in Fig. 116; clearance for the planer should be about 5° . In Fig. 117 is illustrated a round nosed rough-

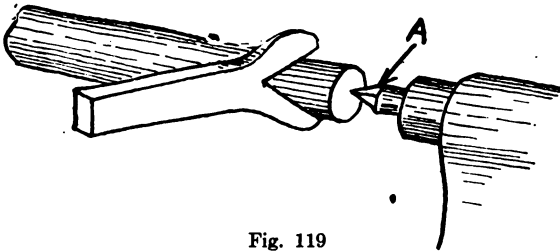

Fig. 119

ing tool, which is serviceable for either cast iron or steel. Satisfactory grinding angles are given in the illustration.

Figure 118 at *A*, illustrates an end convex radius tool, while *B* illustrates an end concave radius tool; at *C* is shown a right hand side concave radius tool. Figure 119

illustrates the use of the centering *Y* and truing center; on certain occasions the workman finds it necessary to center work to be turned, more accurately than is possible by using a center drill and countersink in the usual manner; under such circumstances the work is simply centered and drilled. The truing center *A* is a square center having sharp corners as shown, which are formed at an angle of 60° . The work which has been drilled is mounted on the centers with a dog, the square center being in the footstock spindle; the lathe is started and the *Y* which is supported in the tool post is forced gently against the work while it is revolving, the footstock spindle handwheel being used to feed the square center ahead slightly to produce the required size of counter sink. When a piece thus centered is revolved on the smooth centers, it will be found to run quite true. The operation of centering as described must be performed on each end of the work.

Figure 118 at *D* illustrates a knurl. It is used for producing rough surfaces which enable a workman to obtain a grip on certain parts. A typical example of knurling is the ratchet feed nut shown in Fig. 75. In using the knurl, the holder is mounted in the lathe tool post, so the face of the knurl bears evenly on the work; the work is supported on the lathe centers and by means of the lathe cross feed screw, the knurling rolls are pushed firmly against the surface of the work. The lengthwise feed of the lathe is thrown in, and the carriage allowed to feed over the work as though the piece was being turned. The knurls should be freely lubricated with lard oil, or some other cutting lubricant; machine oil is often used when only a small amount of knurling is to be done and lard oil is not at hand.

Having made an elementary study of bench work and the more common small tools used in the machine shop,

the student is now ready to take up the study of machines. It makes but little difference which machine he begins to study first, since all are used for very simple operations as well as for very complicated ones, but he will, of course, begin with the study of simple operations on any machine. As almost every shop doing any kind of machine work must use a lathe, and since this is one of the basic tools of the machine industry, we will start our study with the lathe.

Every machine tool, regardless of its purpose, is a combination of certain devices for obtaining desired results; it must be started and stopped, hence it must have a starting and stopping mechanism; it must operate, hence it must have a driving mechanism; it must carry the cutting tool over the work, so it must have a feeding mechanism; and it must also have proper support for the cutting tool and means for carrying the work. All modern machines have means of changing the feeds and speeds when operating, in order that various classes of work may be accommodated. Now, whenever you see a machine tool, just analyze it as outlined above, regardless of its appearance, and you will find that it will become simple, assuming that you have a knowledge of the elements of machine construction.

This power of machine analysis is very important to the young mechanic, for every machine is slightly different in the details of its construction. We may study a great many different lathes, for example, but no two designs produced by different makers will be exactly the same in constructive detail. Each one will, nevertheless, introduce all the elements mentioned above. The power of analysis should be developed by the learner. Every machine which you see should be studied for the method of starting, speed and feed control, method of mounting work, method of guiding cutting tool and so on, until

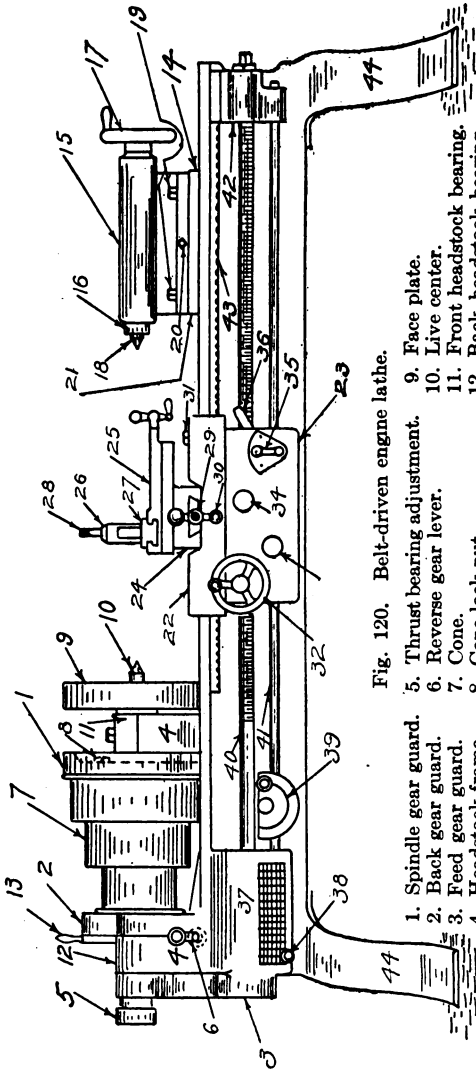

Fig. 120. Belt-driven engine lathe.

- | | | |
|---|------------------------------|--|
| 1. Spindle gear guard. | 9. Face plate. | 32. Longitudinal feed handwheel. |
| 2. Back gear guard. | 10. Live center. | 33. Longitudinal feed locking knob. |
| 3. Feed gear guard. | 11. Front headstock bearing. | 34. Cross feed locking knob. |
| 4. Headstock frame. | 12. Back headstock bearing. | 35. Longitudinal feed reversing lever. |
| 5. Spindle gear shifting handle. | | 36. Lead screw nut locking lever. |
| 6. Footstock base. | | 37. Gear box. |
| 7. Footstock spindle. | | 38. Tumbler gear lever. |
| 8. Dead center. | | 39. Index lever and quadrant. |
| 9. Footstock clamp screw. | | 40. Lead screw. |
| 10. Footstock cap or poppet head adjusting screw. | | 41. Feed rod. |
| 11. Footstock spindle handwheel. | | 42. Lead screw and feed rod bearing. |
| 12. Footstock cap or poppet head adjusting screw. | | 43. Feed rack. |
| 13. Back gear shifting handle. | | 44. Legs. |
| 14. Footstock base. | | |
| 15. Footstock cap or poppet head. | | |
| 16. Footstock spindle. | | |
| 17. Footstock spindle handwheel. | | |
| 18. Dead center. | | |
| 19. Footstock clamp screw. | | |
| 20. Footstock cap or poppet head adjusting screw. | | |
| 21. Index mark on face of footstock base. | | |
| 22. Saddle. | | |
| 23. Apron. | | |
| 24. Cross slide. | | |
| 25. Compound rest. | | |
| 26. Tool post. | | |
| 27. Tool post ring. | | |
| 28. Tool post screw. | | |
| 29. Cross feed screw. | | |
| 30. Cross feed handle. | | |
| 31. Carriage clamp bolt; sometimes located at rear of saddle. | | |
| 32. Longitudinal feed handwheel. | | |
| 33. Longitudinal feed locking knob. | | |
| 34. Cross feed locking knob. | | |
| 35. Longitudinal feed reversing lever. | | |
| 36. Lead screw nut locking lever. | | |
| 37. Gear box. | | |
| 38. Tumbler gear lever. | | |
| 39. Index lever and quadrant. | | |
| 40. Lead screw. | | |
| 41. Feed rod. | | |
| 42. Lead screw and feed rod bearing. | | |
| 43. Feed rack. | | |
| 44. Legs. | | |

all the functions of the machine are understood. In the study of the machine tools shown in this text one typical tool of each type is introduced. All lathes which may be seen by the learner will not be equipped exactly like the one illustrated, but all will be built along the same general lines. All milling machines will not be of the same detail construction as the one shown, but all will be composed of the same fundamental elements. It is the recognition of these fundamental elements, and the study of the related mechanisms, that are very important factors in the learning of the machinist's trade. A wide

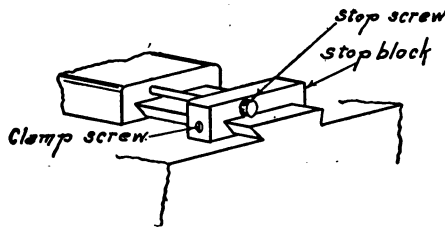

Fig. 120 B

knowledge of tool operation, and an assurance of one's self when entering a new shop, may be rapidly developed by studying the many different machines met in daily occupation at the machinist's trade.

In Fig. 120 we have an illustration of one type of an engine lathe. It is classified as a belt driven tool, and the names of the various parts of the tool are given in connection with the drawing. Figures 120 B and 120 D illustrate a number of attachments, the use of which will be explained as we proceed with the study of this type of machine. The headstock on the lathe is the driving element, and serves to support entirely or in part the work being operated upon; the footstock assists in supporting the work, the carriage is used to carry the

cutting tool while operating on the work, and the feeding mechanism moves the carriage when cutting.

Some of the older lathes operate the feed rod by means of belts on small cones instead of gears, the cones being located in the same relative place as the gearing illustrated in the present drawing. A belted feed is not positive, and usually is not desirable on a machine used for

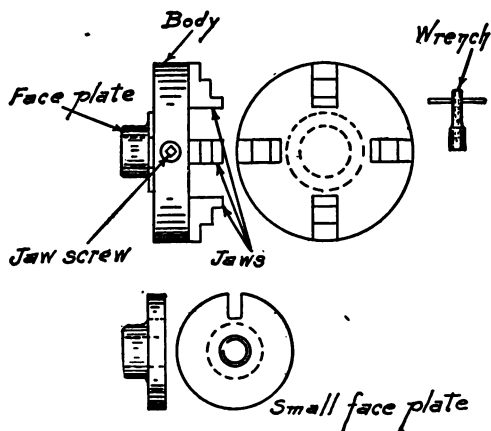

Fig. 120 D

rapid production; for light work, however, belt feeds are very satisfactory.

The first thing a beginner should do is to become familiar with the movements of the machine he plans to operate; no work should be attempted until he is familiar with the control of the machine in detail. Learn to start it and stop it, to change the speed either by shifting the belt or throwing the shifting levers, to throw the feeds of all kinds into and out of gear, and to oil it properly. Remember that in handling machinery one must be careful, and though he may learn to work very rapidly, he must never abuse the machine.

Assuming that the beginner has learned to handle the lathe as outlined above, we may take up the method of doing a simple job, namely, turning a straight bar; now much depends on the accuracy demanded in your work as to the procedure to be followed, but we will assume that you are to turn a piece to an accurately finished size, and finish it by means of the file. In modern rapid production this plan of finishing a straight bar is not followed, although it is followed in small shops doing repair work, of which there are a great many. We will study the grinder somewhat later, and then we will discuss the lathe in relation to this machine.

The first step is to center the work by means of the hermaphrodite caliper, center punch, center drill, and countersink. The centering process at the bench has already been described. A center drill is a small drill used for drilling a hole in the end of the work, and a countersink is used to

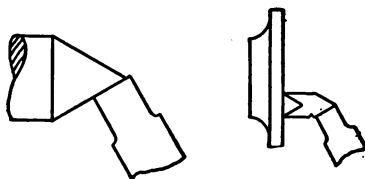

Fig. 121

enlarge the end of this hole, so that it will run nicely on the lathe centers. Usually the workman uses a "speed lathe" for centering, because it is a much more simple tool than the engine lathe, and can be run at a higher speed. This latter feature is desirable, because the center drill is quite small in diameter and must revolve quite rapidly in order to cut efficiently. If you are drilling steel, put a little oil on both drill and countersink while cutting, but oil is not used when drilling cast iron or brass.

After centering, the next step is facing the work, and preparatory to this operation we should test the lathe centers to see that they run true. First, knock the head-

102 PRACTICAL MACHINE SHOP PRACTICE

stock center out by means of a rod reaching through the spindle, or, in the case of a solid spindle, twist the center out by means of a wrench used on the flat or square which is formed on the center for this purpose. Then back out the footstock center by means of the footstock spindle screw, by simply turning the screw so that the spindle draws into the footstock casting till it pushes the center out; wipe these centers off with the hand, and wipe out the holes in the spindle with a piece of cloth or paper. Now look at the live center and see if there is a center punch mark on it, and if there is, this mark on the center should be set just in line with a similar mark on the front end of the spindle. Then set a shovel nose tool as shown in Fig. 121, start the lathe and see if the center runs true. If it does, nothing more need be done, but if it does not, it must be trued up. If it is a soft headstock center, we use a shovel nose tool to true it, if it is a hard headstock center, it must be ground. Figure 121 shows how to set up the tool to true the center when it is soft.

In taking the cut, hold the carriage by the longitudinal feed handle, or lock it with the carriage binding screw so it cannot move along the ways, and, by moving the cross slide feed screw handle, take light cuts till the center runs true. Be sure to test the angle with the center gage. After truing with the tool, speed up the lathe and use a 6" smooth float file to smooth the surface just turned, then polish with a piece of 00 emery cloth, and the center is ready for use. The center used in the headstock of a lathe is known as the live center, while that used in the footstock is known as the dead center. After the live center has been trued, we should see that the dead center is in good shape. The dead center does not need truing as frequently as the live; it need not be trued unless the surface has become worn or scored.

Figure 122 shows a sketch of a tool post center grinder; commonly this device is built in such a way that some portion of it acts as a gage for setting the tool, so that the center is ground accurately. One should always test the center with the center gage as a final cut must usually be taken to correct slight errors, even though the grinder may have been set accurately. If there is no gage piece on the grinder, it must be set as near to the proper angle as one can judge, by traversing the wheel along the surface of the center to be ground; then true the center

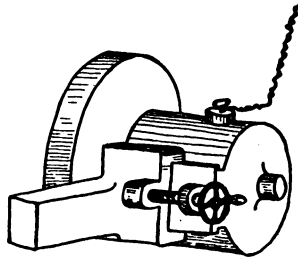

Fig. 122

to this angle, and test with center gage: readjust grinder and take successive cuts, testing after each cut, till the center fits the gage.

If no center grinder is available, the footstock center must be trued with the tool in the same manner as the live center. Since the dead center is hardened, it must be annealed before we can work on it. This process is described in the chapter under hardening, tempering, and annealing. After truing the center, it must be hardened and tempered before it is placed in use, and if both centers are to be refinished, it is always wise to true the dead center first, as such a plan will leave the live center in place after it has been trued. This is a desirable point, because when a center is removed it is sometimes slightly out of true after it is replaced. In some large shops all centers are hardened and ground all over; this is a very desirable plan, as it does away with a great deal of truing of centers.

If our centers are in good shape, we are ready to start work on our piece. The first step is to face it up, using

a right hand side tool, end ground so we can get well down to the center, and, by very slightly slacking back the footstock spindle, remove the slight burr left around the edge of the countersink hole. Be sure when operating a lathe to keep the footstock center well oiled; a drop of oil on the center each time the work is replaced will take care of this. Keep the centers and center holes clean also. The side tool, when being used for facing, should be set so that its upper cutting edge is just level with the point of the lathe center, as this gives the best working position.

Before we start turning we must assure ourselves that the lathe is set to turn the piece straight, and there are a number of ways of making this test, but one of the simplest methods is to take a right hand side tool and very slightly round the end of the cutting point. Next take a mandrel and place it on the lathe centers, place the tool in the tool post, and move it towards the mandrel until it just pinches a piece of newspaper, held between the point of the tool and the surface of the mandrel. This adjustment should be made at the footstock end of the mandrel. Let the tool stand in its position, remove the mandrel from the centers, run the carriage up against the headstock of the lathe, replace the mandrel on the centers, being sure that the end which was formerly towards the footstock is now placed towards the headstock; that is, we turn the mandrel end for end. Now hold the paper in place, and very carefully move the tool back, and see if it just pinches the paper; if it does, the lathe will turn straight, but if it does not, we must adjust the footstock cap by means of the adjusting screw till we get the desired result. See line drawing of lathe for location of footstock parts mentioned in this description.

In order to get the centers approximately in line, we may simply slide the footstock up towards the headstock

till the two centers just touch, and, by means of footstock adjusting screw, set the centers as near true as we can judge with the eye. This is all the adjustment that is necessary for rough work, but for accurate work we must use the detailed method just described.

For turning this piece of work we will use a diamond point, and it should set as shown in Fig. 123, somewhat above the center line of the lathe, so as to give a good shear or clean cutting action. Now having both ends of the piece faced, we put on the dog, or carrier as it is sometimes called, place the work in the centers, start the lathe, move the tool in place by

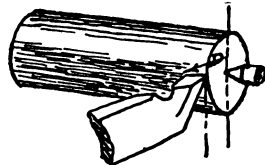

Fig. 123

means of the cross slide, and start a light cut by means of the lengthwise feed handle. As soon as cut is started, throw in the feed and let the carriage run up about $\frac{1}{8}$ "; now stop the machine and caliper your work to be sure it is not too small. If it is, we must reset the tool, and if we have not run the cut up too far, the work is not spoiled; if, however, we have run the cut up a half inch or more,

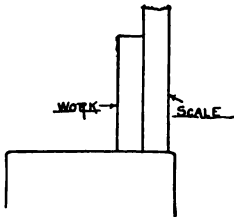

Fig. 124

and have set the tool for too deep a cut, the piece will be useless. Assuming that our cut is the correct size for a roughing cut, we let the tool feed up about one half the length of the piece, run it back towards the tailstock, remove the work from the centers, place the dog on the turned portion, replace it on the centers, and rough off the remaining section of the piece.

All the work described thus far has been a roughing out process. The piece must now be finished, and there

is no new element of operation to be described except to suggest that all tools for finishing be oil stoned after grinding. In taking the finish cuts on facing up, one must measure the piece carefully for length; Fig. 124 shows a very good method of making this measurement. In doing lathe work of the sort described, it is always wise to rough out first, and then finish.

Parting or Cutting Off. — One of the common operations on the lathe is cutting off stock, but as the process requires some experience with the action of cutting tools, it does not make a good job on which to start a beginner. It is wiser to start with a job of facing and straight turning, which will give an appreciation of the care necessary in handling cutting tools. In parting, have the tool set, so that the top edge is about $\frac{1}{32}$ " above the point of the lathe center; be sure that the tool has both end and side clearance; feed slowly, and use a cutting lubricant; if your work is held between centers of the lathe, do not cut it completely off, as you are apt to break the tool by so doing, and damage the centers; cut down so that the diameter of the section between the pieces to be parted is about $\frac{3}{16}$ " in diameter; remove the work from the lathe and break the pieces apart in the vise.

Chuck Work. — The next step which the beginner may take introduces one of the attachments of the lathe, known as a chuck. Figure 120 *D* presents the names of the parts of this attachment, and the student should familiarize himself with these before going farther. To use the chuck, the driving face plate (see drawing of lathe), is unscrewed from the lathe spindle. See that the threads on the spindle are clean, and also the threads in the chuck faceplate, and that there is no dirt on the surface of the shoulder on the spindle, nor on the edge of the chuck faceplate. When these points are looked after, the chuck should be screwed solidly on the spindle.

A little point in connection with the removal of a faceplate or chuck might be mentioned here; some workmen use a hammer striking on the edge of the faceplate slot, or on a jaw of the chuck; a much better plan, however, is to put a bar in the faceplate slot and strike this bar with the hammer. Use a block under the jaw of the chuck and run the lathe backward to slack it off.

Now as to the method of using. The chuck is used to hold pieces while working on an inside surface, when drilling a hole in a piece of stock, or when facing large flat stock. Figure 125 shows a typical job requiring a

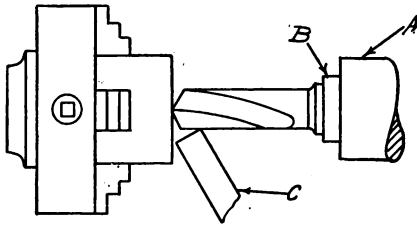

Fig. 125

A is the footstock spindle.
B is the collet holding drill.
C is the support for drill.

chuck; it is a bushing used about an engine. To describe the operations, let us assume that we are to make the bushing from a piece of solid stock. Our first step is to true the piece in the chuck, and this is done by opening the chuck jaws, and catching the stock as shown in Fig. 125; now start the lathe, running it at a high speed, and hold a piece of chalk steadily in the hand; the chalk will strike in one spot; stop the machine and reset the chuck jaws, moving the marked spot in towards the center of rotation or axis of the lathe spindle; clean off the first chalk mark, and repeat the above operation till the chalk produces a mark all, or nearly all the way, around the

piece; the work is now said to be running true. This operation takes patience, but with practice one can do it very rapidly.

After the work is running true, the next step is to drill a hole in it, and so we will need a right hand side tool, a proper size reamer drill, and a collet to hold this drill, which will fit the footstock spindle of the lathe. Put the drill in place in the footstock spindle, place the side tool in the tool post, and face off the end of the piece in the same way we did when doing the job of straight turning; now, with the footstock spindle drawn well back, so that the drill is well supported in the spindle, move the footstock up so the point of the drill is about $\frac{3}{4}$ " from the face of the piece, and clamp the footstock solidly in place. Then turn the tool around in the post, bring the drill up till it begins to cut, feed slowly, run the blunt end of the side tool up just so it supports the drill and prevents it from moving sidewise. Feed slowly, and keep the drill steady by supporting it with the side tool till it is in the work about $\frac{1}{8}$ " of its full size, when the tool may be removed, as the drill will now "keep its lead." See Fig. 125.

When drilling in steel or wrought iron, be sure to use some kind of a lubricant. You may feed the drill to the work by means of the hand wheel at the end of the footstock spindle, and, as it begins to break through at the inner end of the work, feed somewhat more carefully, in order that it may not catch or "bight" and be broken. After drilling, remove the work from the chuck and ream with a hand reamer; use a little lard oil or other lubricant whenever reaming steel or similar materials, but, as a general rule, oil is not used when working cast iron for any process but tapping.

In the job we have just studied, our reamer drill would be about $\frac{1}{8}$ " smaller in diameter than the finished size

of the hole, leaving this amount to be removed by the reamer, and producing a hole accurate to size. After reaming, we should test the bushing with a standard plug gage to be sure that our reamer is of proper size.

The finishing of this bushing introduces the use of the mandrel. Having drilled and reamed the piece, get from the tool room the proper sized mandrel and a dog, put a little oil on the mandrel, and setting the work on a mandrel block (or on the jaws of a vise), as shown in Fig. 103, drive the mandrel into the work, using a lead hammer. Never use a steel hammer to drive a mandrel in place. In starting the mandrel, you will find one end slightly smaller than the other, and of course it is the smaller end which should be entered in the hole in the work. Now be sure that the centers in the mandrel are clean, put a little oil on the dead center of the lathe, and set the mandrel on the centers in just the same way that you did when the bar to be turned was placed between the centers. The first step to be taken is to rough face the work, which need be done on only one end, and this consists of simply running a facing cut over it. Now take the diamond point, set it so that the top of the cutting edge is somewhat above the center line of the lathe, thus insuring a good cutting action, and start a cut; let it run about $\frac{1}{8}$ " , stop the machine, having your caliper set to the roughing size of the work which should be about $\frac{1}{32}$ " larger than the finish size, and see that you are not turning the work too small. If you are safe, and the cut is a good sized one, which will remove a reasonable amount of stock, let it run over the work; if it is necessary, repeat the operation until you have the bushing roughed down to the proper diameter.

Now take the work off the centers, put the dog on the other end of the mandrel, and rough face the other end of the work. After this is done, sharpen the diamond

point, using an oil stone if you want a very smooth cut, and run a finishing cut over the work. Be careful not to get the work too small, and, in calipering, never force the measuring instrument over the piece, but work with care, so that you know the exact measurement of the bushing after you have turned it. The finish facing may now be done, using the left hand side tool for one face as shown in Fig. 115, being sure that you obtain a smooth cut by setting the tool so that it cuts on the face and not on the point. Note that the left hand side tool is used for facing up left hand faces of work such as that with which we are dealing at present. The right hand side tool is used for facing the right hand shoulders. To finish this bushing to accurate length, the outside caliper is used for measuring the dimension.

It will be necessary to finish the surface of this bushing by filing and polishing with emery cloth. Use a second cut float file for filing, and keep it clean with a file card. Use a speed lathe, if you can get it, rather than an engine lathe for filing and polishing. Speed up the machine, and file with slow regular strokes, pushing the file from you, the same as when filing at the bench; do not file a job of this sort very much; just enough to smooth the surface, and no more. Round the corners slightly with the file, put a little oil on it, and polish with emery cloth, moving the emery cloth slowly back and forth along the length of the piece while the work is revolving rapidly; wipe off with a piece of waste, drive out the mandrel, take a three cornered scraper, which is a three cornered file having the teeth ground off so the corner forms a sharp cutting edge, and scrape away the little ragged sections around the edge of the hole, and the job is done.

We have now studied the three most common jobs on the lathe, namely, facing, straight turning, and chuck-

ing. We have also done facing on work carried directly on the centers and on a mandrel as well.

The machinist's trade is a calling demanding great accuracy on the part of the worker; in the jobs we have done thus far we were working simply to certain dimensions; it was not necessary to fit one piece to another. But fitting must be done on a great deal of work, and the fits used are the running fit, taper fit, driving fit and shrink fit; all these fits are made by variations of diameter, between the shaft and the hole in the hub of a wheel. Table X gives a list of allowances for making the various fits; the words "large" and "small" as used at the head of the columns, refer to the amount larger or smaller than standard diameter which the shaft is turned in order to give the required fit in a hole of exact standard size.

For example, let us assume that we have a hole in a hub that is exactly 6" diameter, and we wish to turn a shaft so that we will have a good driving fit in it; we would then turn the shaft 6.0035" diameter, which is 0.0035" larger than standard size. Again, suppose we wished this shaft to be such a fit that the hub would run nicely, without unnecessary shake we would turn the shaft 5.996" diameter, or somewhat smaller than the exact size; it is wise to keep this table constantly at hand, as it is very convenient in daily work. We do not attempt to turn the work to these exact sizes with a tool, but we usually turn about two or three thousandths of an inch larger than the finished size, and bring it to the exact size by filing. After the shaft is worked to size, the surface is lubricated with lard oil or tallow, and driven in place with a hammer or sledge.

In looking at the column for shrink fits, it is to be noticed that a larger allowance is used than for the making of a driving fit, but the preparation of both shaft and

hub is made in the same way as in the case of the driving fit. The placing of the parts together is done in a different way, however, as follows: after both hub and shaft are prepared, the hub is slowly heated, always starting the heat from the outside, never from the inside first, and bringing it up to a low red heat; now while the hub is hot, the shaft is carefully slipped in place, and the hub allowed to cool; as it cools it will grip the shaft firmly and remain solidly in place, if the workman has done a good job. In making this fit no driving is done. For much of the work now done in the machine shop, the heating is undesirable, and since facilities have been developed in the modern plant for making the forced fit, the shrink fit is not so commonly met.

The forced fit allowance is greater than either the drive or shrink fit allowance. The manner of preparing the parts for a forced fit is not different from the preparation of the drive or shrink fit; the parts, after such preparation are forced together, either with a screw press, an hydraulic pressing machine, or a pneumatic machine. The screw press is commonly used for small work, while the other methods are used for large work, such as armature shafts for generators, etc.

The young mechanic should seek the opportunity of making all these fits, as considerable skill is required in the work, and this skill can be obtained only by actual practice. A very good lubricant for use on a shaft when making a forcing fit is melted tallow and white lead, enough white lead being stirred in the melted tallow to give it the consistency of a heavy paint.

Thread Cutting.—Since thread cutting involves a number of important elementary points in machine shop practice, and since it introduces some very interesting calculations, we may take this subject up as our next study. The thread is produced by forming a helical cut

on a cylindrical body, and is used on all bolts and screws. There are a great many different kinds of threads, but the one most commonly used in America is known as the United States standard thread, and since by the study of this standard we may gather much valuable information which is useful in connection with any threading system we will for the present devote our attention to this thread.

In examining the U. S. standard thread we find that for each diameter of bolt used, there are a certain number

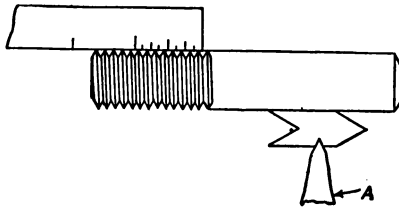

Fig. 126

of threads per inch of length. To measure these, lay a steel rule on the threaded portion of the bolt as shown in Fig. 126 and count the number of threads between the one inch divisions of the scale; if the threads are not long enough to span a whole inch, count the number spanned by a half or a quarter of an inch and multiply by two or four to get the number of threads per inch.

Let us study the table II and become familiar with the number of threads per inch of length, for each diameter of bolt, as it is required that any U. S. standard thread shall conform to the number of threads as listed in this table. In looking at this table, you will notice that there is given not only the diameter of the bolt and corresponding number of threads per inch, but also the vari-

ous sizes of the hole in the nut which will permit the formation of the thread.

It will be recalled that the tap drill was mentioned in an earlier chapter, and it was stated that the only difference between this drill and any other standard twist drill was one of diameter. In the column marked "approximate size" we have the diameter of the drills commonly used as tap drills for the respective size bolts shown in the table. For general shop practice the other two columns are not necessary, but for jig and fixture designing they are very useful, as the designer, after glancing at them, knows the exact relation of the diameter of the drilled hole to the diameter of the bolt, at the bottom of the thread.

The column headed "set thread micrometer" gives us the proper reading of the thread micrometer caliper, when the thread has been cut to size. Every young machinist should have a copy of Brown and Sharpe's or Starrett's small tool catalog, in which will be found a description of the thread micrometer, with instructions concerning the method of reading it. These catalogs may be obtained by writing the Brown and Sharpe Mfg. Co., Providence, R. I., or the L. S. Starrett Co., Athol, Mass.

Figure 127 shows a section of a U. S. standard thread and we notice it is slightly flat at the top and bottom. For general shop practice the workman does not attempt to produce the flat with any degree of accuracy in the smaller sizes, that is from $\frac{1}{4}$ " to about 1"; he simply rounds the end of the cutting tool slightly by the use of an oil stone, but for the larger sizes this flat is formed. Looking at Fig. 127 we see how this flat portion is obtained, and its purpose is to assure better wearing qualities when the thread is in service. The flat is equal to one eighth of the depth of the thread.

We now have two new terms with which to familiarize ourselves; these are "pitch" and "lead" as applied to threads; the "pitch" of a thread is the distance from the center of one thread to the center of the next, as shown in Fig. 127 at *a*. In order that we may understand the term "lead" let us assume that we have a piece of work with a thread cut on it, and a nut properly fitting this thread; now let us turn the screw in the nut, just one turn, then the amount that the end of the screw moves, relative to the face of the nut, is known as the lead. In

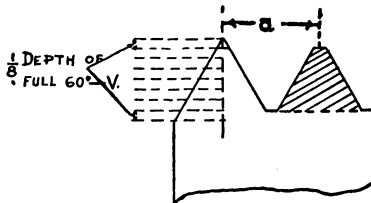

Fig. 127

the more commonly used threads the pitch equals the lead, but in multiple threads this statement does not hold true. In the present volume, only single threads are discussed, that is, those threads having the lead and pitch equal.

Threads are usually cut in the engine lathe, and as a problem we will assume that we wish to cut a thread on the straight piece of work illustrated in Fig. 126. The thread cutting tool must be so ground that it fits the notch in the side of the center gage, Fig. 54; this will require some patience, but the student should persevere until he can grind the tool properly, for if he does a good job each time he has occasion to grind a thread tool he will soon be able to do a good piece of work, and do it quickly.

After grinding the thread tool, the work should be

placed on the centers, being sure that the center holes are clean, and that the dead center is oiled, also that a dog is placed on one end of the work, with a piece of copper under the set screw. Now put the diamond point in the tool post and champher off the end of the work as shown in Fig. 126 where we see the work as it will appear when ready to put on the centers. The thread tool should now be set true by means of the center gage, using it as illustrated in Fig. 126 at A. Don't jamb the tool into the gage but set it as nearly true as you can judge with the eye, and then by tapping it on the shank with a hammer adjust it so it fits exactly in the notch. A piece of paper placed beneath the tool is of assistance in setting it, because the paper will throw a light between the tool and the gage, enabling one to see more clearly the necessary movement required for correct setting.

The next step is the placing of the proper gears in position to advance the carriage the correct amount for each revolution of the lathe, in order to produce the required thread. In the most modern lathes this is effected by the placing of certain levers in particular positions, which positions are determined by the study of a diagram, which is often arranged on a brass plate, and mounted directly on the machine. In other cases, this diagram is printed on heavy cardboard, and kept in the tool cabinet of the machine. The study of this diagram is the next step. The setting for cutting a thread on these machines usually requires the shifting of two levers, one of which we call the index lever and the other the tumbler lever. The index lever may be set in four or five different positions and for each position of this lever there are from ten to twelve positions of the tumbler lever, giving a different speed ratio between the spindle and the lead screw for each position of the latter. Thus,

if we have five positions for the index lever, and eleven positions of the tumbler for each setting of the index lever, we have available fifty-five combinations for cutting threads; as most of these gearing arrangements are designed on similar lines, so far as operation is concerned, we will study but one design.

Whenever a person is called upon to operate this type of gear change, he should first locate the index lever, which will be designed to take a few positions, while the tumbler lever may take a greater number of positions. Having located these levers study the diagram for the

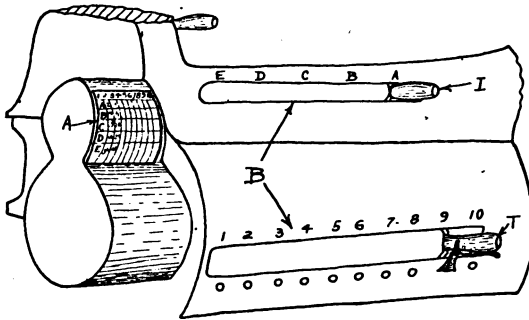

Fig. 128

various settings; Fig. 128 shows a diagram at *A* and lever arrangement at *B* of a modern tool; *I* is the index handle and *T* is the tumbler handle.

The piece of work we are to thread is $\frac{3}{4}$ " in diameter; looking at the table II we see that we should have ten threads per inch of length; now looking at the diagram we see the number 10 in the second column. The diagram also shows that the index lever should be set under *C*; we will slide this lever to the required position. The tumbler lever is set in #3; the lathe is now said to be geared up and we are ready to start thread cutting. It

depends on the setting of the reverse gear lever at 6, Fig. 120, whether we cut a right or left hand thread; if a thread is so cut on a piece of stock, that in turning the work in the same direction that the hands of a clock move, we advance the work in the nut, it is known as a right hand thread. If it advances when we turn it in a direction opposite to the movement of the hands of a clock, it is a left hand thread. On most bolts and screws a right hand thread is used, and this is the type of thread we plan to cut; you will find that by placing the reverse gear lever in position indicated by the full lines the carriage will move in one direction when the lathe is running ahead, and by placing the gear lever in the position indicated by the dotted lines the carriage will move in the opposite direction when the lathe is running ahead.

To cut a right hand thread the carriage must move towards the headstock when the lathe is running ahead; with the reverse gears set in the proper position, throw in the lead screw nut lever 36, Fig. 120, and the machine is ready for the operation of thread cutting. The cutting of a thread requires considerable practice, since the workman must attend to a number of movements at one time. He must be able to reverse the lathe, place the tool in the cutting position, remove it at the proper time and adjust the thread stop; all of these operations must be carried on while the machine is running.

The first step for the beginner, after the machine is geared up, is to practice the necessary movements, learning to control the various movements accurately, before the tool is started on the cut; run the carriage back and forth, move the cross slide, and adjust the thread stop. After you have control of these operations, set the thread stop block Fig. 120 *B* so the end of the thread tool just touches the surface of the work; now with a divider or

hermaphrodite caliper, place a mark on the work, showing where the thread is to stop. By means of the cross slide screw, run the tool back so it is clear of the work, reverse the lathe bringing the tool to the end of the work, shift the lever starting the machine ahead, and at the same time operate the cross slide handle to bring the tool into the position limited by the thread stop. Be sure the thread stop is solidly clamped so it acts as a positive stop for the cross slide; let the tool run ahead and, if your setting has been properly done, the tool will take a light cut; watch the work closely, and, when you reach the line limiting the length of the thread, quickly withdraw the cutter, at the same time reversing the lathe. Adjust the thread stop screw (see Fig. 120 *B*) very slightly while the lathe is running backward, so the tool takes a slight cut as it passes over the work. Repeat this operation, always using a lubricant on the cutting tool if you are working in steel, but omitting it if you are working in brass or cast iron. As the thread is worked down one must be careful, or it will be made too small, so the workman should have a gage at hand to which the thread is fitted; the nut which is to be used on the bolt often serves the purpose of a gage. The work should be taken from the centers frequently and tried in the gage until the thread works easily but without shake; skill in fitting can be gained only by practice and it requires considerable time and patience.

Having cut a thread on one end of the piece, we must cut a thread on the other end. The piece we are making is called a stud, and it is much used in machine construction. A stud is very similar to a bolt, only it has a thread on each end. To cut the thread on the other end of the stud, the dog must be placed on the section just threaded; the dog set screw must not be jammed down directly on the work, as this would damage the

thread. A thread bushing, Fig. 129, should be obtained from the tool room, and screwed on the end of the stud, the set screw being closed on the bushing in such a way as to pinch it on the work solidly, and prevent any movement. Place the work on the centers, and cut this thread in exactly the same manner described for the first thread.



Fig. 129

Clamp dog set screw
on flat shown at A.

Cutting Left Hand Threads. —

The cutting of a left hand thread introduces the same steps as a right hand, the only difference being that the carriage moves towards the foot-stock on the cut, when the lathe is running forward.

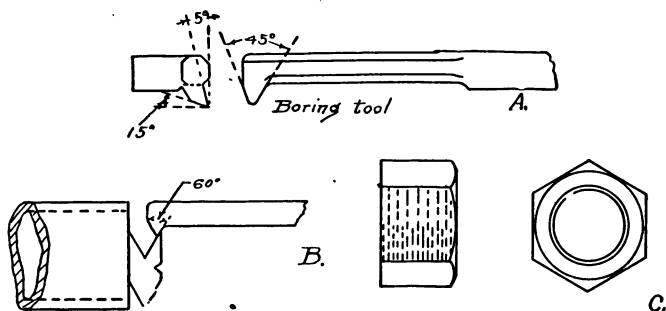

Fig. 130

Cutting inside threads. The boring tool is shown at A; figures on this drawing give satisfactory cutting angles to which cutting point may be ground.

Cutting Internal or Inside Threads. — This work introduces some steps which we have not met thus far, as well as some new tools. Figure 130 shows a boring tool which is used for finishing internal surfaces in the lathe, when the job is too large to permit reaming. The job to be done is a large nut, used on a marine engine, and

shown in Fig. 130 at *C*, and in Fig. 130 at *B* is illustrated the way a boring tool is ground, converting it into an inside thread tool; notice the angle given on the tool, Fig. 130 *B*, and the slightly rounded end of the cutting tool, similar to that formed on the outside threading tool. The blank from which the nut is made is first trued up in the chuck as previously described, and a hole drilled which is about $\frac{1}{8}$ " smaller in diameter than the size at the bottom of the thread which the nut is to fit. The boring tool is then put in place, and set so the top of the cutting point is level with the center of the lathe. Start the machine being sure the tool is set as far back in the tool post as possible, and yet extending far enough to pass through the work. Pick up the cut and feed in about $\frac{1}{8}$ ", then use the inside caliper to test the diameter. There are two ways of setting the inside caliper; one is to use the micrometer caliper to get the exact size, then to set the inside caliper to the micrometer, and the other is to set the inside caliper directly from the scale. The former is the more accurate method, but the degree of accuracy possible by this method is not necessary on such a job as we have in hand at present, so the inside caliper may be set directly from the scale, by placing it against the try square as illustrated in Fig. 131. To determine the proper dimension for setting the inside caliper, look at the table II and take the size from the column headed "approximate size." The screw which fitted the nut we are making was $1\frac{1}{4}$ " outside diameter, so we must cut seven threads per inch to meet the United States standard requirements, and the diameter of the hole must be $1\frac{3}{32}$ ". The proper way to use an inside caliper is illustrated in Fig. 32. After being sure that the cut started is not large enough to remove too much stock from the bore, it is allowed to pass through the work; the last cut taken should be a light one, so the hole will be straight and true.

122 PRACTICAL MACHINE SHOP PRACTICE

After boring the work to size, take a side tool and face off the end so there is a nicely finished face. See that the thread tool is properly ground, with a correct flat at the end, by fitting it to the thread gage, Fig. 58, and set

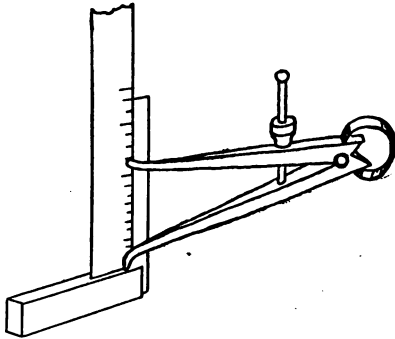

Fig. 131

true with the axis by using the center gage as illustrated in Fig. 130 B. Gear the lathe for cutting seven threads per inch, throw in the lead screw nut, and proceed to cut

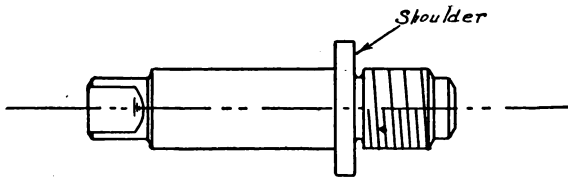

Fig. 132

this thread in the same way that the outside thread was cut. The setting of the thread stop for inside work requires that the stop block (see Fig. 120 B) be removed from the screw and set so the head of screw abuts against the inner face of the stop, thus checking an *outward* cross movement, rather than an *inward* cross movement. The

nut should be fitted either to a screw gage, or the bolt with which it is to be used.

Use of the Nut Mandrel. — In finishing the faces of this nut and turning the outside diameter we must use the nut mandrel, shown in Fig. 132. Whenever a workman selects a piece of stock for a job, he must have it somewhat too large, in order that there may be material enough to finish the piece properly, and we assume that sufficient stock was left on this nut for finishing. Place the nut on the mandrel, with the finished face against the shoulder, and face the unfinished end, leaving about one sixteenth of an inch on the length; champher the face just finished, turn the nut around and take a final finish chip from the face first roughed off in the chuck. The plan outlined assures a nut having both faces true with the bore. The hexagon part of the nut is finished either on the shaper or milling machine.

Calculating Gears for Thread Cutting. — In the examples of thread cutting which we have studied, it has

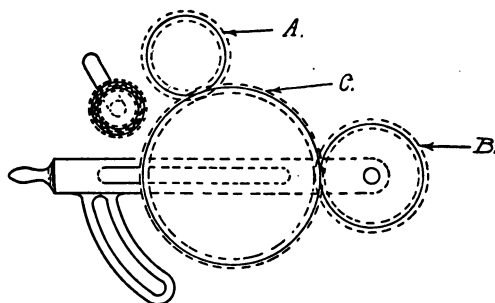

Fig. 13.

A is the stud gear.

B is the screw gear.

C is the intermediate gear.

been assumed that the work was to be done on a modern, rapid production lathe, with fixed gears. There are a great many lathes on the market not so arranged, and it

is an advantage if a lathe for tool room work does not have fixed gears. On some lathes we find the change gears arranged as shown in Fig. 133; the gears *A* and *B* are removable in order that the various gear ratios may be obtained for cutting different threads. On the headstock of the lathe will be found a plate which gives the proper gears to be used for cutting the various threads. There are three columns in this table, one headed "thread," another "stud" and another "screw," and the explanation of these terms is as follows: "thread" gives the number of threads to be cut per inch of length; "stud" gives the proper number of teeth in the gear to be placed at *A*, while "screw" gives the proper number of teeth in the gear to be placed at *B*. The number of the teeth in a change gear is marked with a steel stamp on the rim of the gear.

In gearing up this kind of a lathe, the swing plate is moved up so the intermediate gear *C*, Fig. 133, is in contact with both the stud and lead screw gear; don't jamb the gears together too hard; but set them so they will run easily, and quietly. When gears are set as described they are said to be "in mesh." There are occasions when the workman wishes to cut threads which are not listed in the tables furnished with the machines, and he must make calculations to determine the proper gears. These calculations are taken up in the chapter on Machine Shop Calculations, and the learner should become familiar with the method used for determining the proper gears for use when cutting any thread. After the gears have been selected, and put in mesh as described above, the procedure of thread cutting is the same as that previously described.

Making a Taper Fit. — We recall that in the study of fitting we did not take up taper fitting. There are a number of tapers used on machine tools; the reason why

these tapers are introduced by the designer is because they automatically adjust themselves to wear, and are serviceable for many years, if they are properly used. The most common tapers met in the machine shop are the Morse, Brown and Sharpe, and Jarno tapers. The Morse taper is used for the shanks of drills, counterbores, and all tools used on the driller. The Brown and Sharpe taper is used on all tools fitting the miller. The Jarno taper is not in such general use as the first two mentioned, but it is being placed on some machines by the Pratt and Whitney Co. and is of service to the designer of special machinery and tools; the Jarno taper is the most logically designed of any of the proposed tapers. The taper takes its name from the pen name of the late Mr. Oscar J. Beale, who used the name "Jarno" when signing many of the technical articles which he wrote.

A workman should have at hand in the shop a table giving the properties of the various tapers as listed in table XII; furthermore these tapers should be thoroughly understood by him.

As to fitting a taper, let us assume that we are to turn and fit a taper shank on a twist drill. The blank must first be faced, and the body of the drill roughed out. If there is more than one drill to be fitted, square all your pieces up to the same length, before starting to turn, as this will save work in making the fit.

There are two methods of turning a taper on the lathe. One is known as the poppet head method, the other as the taper attachment method. Since all lathes are not equipped with a taper attachment, while all engine lathes have a poppet head adjustment, we will study the poppet head method first. Figure 120 gives a detailed view of a footstock, and shows how the top part is mounted on a base. This top part is adjusted by means of two screws one of which (#20, Fig. 120) is seen; the other is

at the back of the footstock. Before making any adjustments, look at the index mark 21, on the front or back of the poppet head, as you will wish to replace the head in its original position after turning the taper. If such a line is not there, get permission from the person in charge of your work to place it.

Tapers are always classified by the amount of enlargement in diameter per foot of length. For example, we state that the Jarno taper is 0.600" per ft.; by this we mean that a piece of stock, one foot long, turned to a Jarno taper, will be 0.600" larger at one end than at the other. Now if we have a piece of work which is but 9" long, the taper will be $\frac{9}{12}$ of 0.600". When turning a taper in the lathe, we must always use the full length of the piece, on which we are working, to determine the amount of "set over" for the poppet head, even though we may be turning a taper only one inch long on the piece; the longer the piece of work, the more we must set the poppet head out of position.

To make this clear, and also, to enable us to develop a rule for calculating the amount of "set over" for the poppet head, let us study Fig. 123. We may assume that the points of the centers of the lathe are 12" apart; in measuring a taper we recall that we considered the *diameter* of its parts. If one thinks for a moment, he will see that the distance from the point of the cutting tool that is being used to the center line of the lathe is equal to the radius of the work. Now if we move the poppet head in the direction *D*, Fig. 123, towards the cutting tool, we will lessen the radius of the work by just the amount that we move the poppet head, and we will lessen the diameter by twice this amount. From this reasoning we may conclude that we need to move the poppet head only one half as much as we wish to vary the diameter. Thus, if we have the piece for the Jarno taper and it is

12" long, the variation in diameter for this length being 0.600", then we need set the poppet head out only 0.300".

All of our work is not exactly 12" long, however; returning to our lathe, let us move the footstock towards the headstock, till the center points are but one inch apart. It is evident that if we were to turn a piece with the centers in this position, and the same set over of the poppet head, we would not have a taper of 0.600" per ft. but 0.600" per inch. If we want to turn a piece that is one inch long to a taper of 0.600" per ft. we must reduce the amount of set over; since our work is 1" long, or $\frac{1}{12}$ of a foot, we will set the poppet head over $\frac{1}{12}$ the amount we would if we were turning a piece of stock 12" long.

Reviewing the steps we have taken we find that we first divided the taper per foot of our work by 2, and then we divided the length of the piece we wished to turn by 12, and multiplied these values together, thus obtaining the proper setting. We have then the following rule: divide the length of the piece by 12; multiply this quotient by one half of the required taper per foot, and the result is the proper amount of "set over." In using this rule, all dimensions should be taken in inches. We may put this rule into a formula in the following manner:

- L = Length of piece of work in inches
- t = Desired taper per foot; in inches.
- x = Required set over

Formula:

$$\frac{L}{12} \cdot \frac{t}{2} = x$$

Due to the fact that we have center holes in our work, which are not exact in diameter, this formula will not give an absolutely accurate result. It will give a suffi-

ciently close approximation, however, to make the first setting of the poppet head, and the final adjustment must be made by fitting.

The first step in making a taper fit, after placing the work between centers, and setting the poppet head, is to start a light cut. Do not take too large a cut, as a very small amount of excess material removed from a piece will spoil a taper. Now set the inside caliper to the size of the end of the taper hole in the gage, which the shank you are making is to fit. Transfer this dimension to your outside caliper, and set the outside caliper $\frac{1}{4}$ " smaller than this dimension; now turn the end of the shank down to this size. Remove the work from the lathe and make a chalk mark along the taper you have just turned, as indicated by the shaded portion of Fig. 135, then carefully enter the shank into the gage, or col-

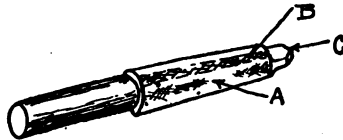

Fig. 135

let, which you may be fitting. Hold the gage and piece firmly, and turn the work slightly back and forth; remove the piece from the collet, and see what effect this operation has had on the chalk marks. If all the chalk appears to be removed, for the whole distance which the work entered the collet, another light cut may be started, and the same test made again after it has been run; the various cuts are repeated till the work is brought to size as described later.

Possibly you will find the chalk wiped off for only a part of the length of the taper, as indicated at A, Fig. 135. This shows that there is too much taper, and the poppet

head must be set more nearly straight; the re-setting movement should be very slight, slacking off the rear binding screw and tightening front binding screw. Set the tool so it just scrapes the shank at the small end, and start the feed. Be sure the cutting tool is sharp, and you will find that the chip will pick up as the feed advances; after this cut has run over, chalk your work again, and make another test. The adjustments described must be repeated till an accurate fit has been obtained.

Suppose, however, that the chalk, instead of wiping off at *A*, Fig. 135, wiped off at *B*. It is evident that we must, under these conditions, make a sharper taper than we have obtained by the original setting of the poppet head. In order to get this effect, we slack off the binding screw at the front of the footstock, and tighten the one at the rear, the movement being very slight. In this case the tool should be started at the large end of the taper, setting it so it just scrapes the surface of the work, and feeding towards the footstock, the chip gradually picking up as the tool feeds. Then proceed with the fitting in the same manner as already described; the work should not be completely finished by turning; about 0.005" should be left for filing as described in connection with the first lathe job.

The Taper Gage.— Figure 24 illustrates a taper gage, used for fitting such work as has just been described. All shanks on drills, counterbores and end mills have a tongue formed on them as at *C*, Fig. 135; this tongue is the driving element when the tool is in service.

When the taper is turned it must be of such a size as to permit this tongue to enter the slot in the collet provided for it. The line on the taper gage at *F*, Fig. 24, indicates the point at which the end of the turned shank

should set, when it is of such a size as to permit the tongue to locate properly in the collet slot, at the same time permitting the taper to seat properly in the collet. After the taper has been fitted, a section of it should be turned straight for a length approximately equal to the diameter at the small end of the taper, and about $\frac{1}{2}$ " smaller in diameter than the smallest part of the taper shank. The end of the tongue should be filed to an angle, as indicated in Fig. 135 at C, in order to permit the use of a drift key.

One often finds himself in a shop where no taper fitting gage is available, and under such circumstances the fit must be made directly to the collet. If this be necessary, mill or file the tongue on the end of the shank first, turn it to the proper diameter, and then proceed to fit the taper.

All taper work does not demand the fitting of a tongue, but as the job described offers an interesting and helpful practice problem, together with some valuable shop detail, the learner will be well repaid, if he masters the various steps involved.

Internal Taper Work. — When the workman is called on to bore a taper hole, there are two methods he may follow. One is to step it out by straight boring, in a series of slight shoulders, each one slightly smaller than the preceding one, and finish with a reamer. The other is to bore the hole by using a taper attachment; Fig. 136 illustrates the first method. The hole is first bored

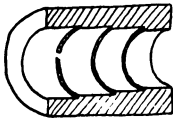

Fig. 136

straight, about $\frac{1}{8}$ " smaller than its final size at the small end; the reamer is then measured at points $\frac{1}{2}$ " — 1" and $1\frac{1}{2}$ " from the end, and shoulders turned at the respective distances from the face of the work. After all the necessary shoulders are formed, the taper reamer is used to

finish the hole to the required size. The hole should always be finished to the size of a taper plug, or fitted to the piece with which it must assemble. Usually the face of the work is trued off, before boring or reaming the hole, and the fitting is continued until this face sets at a desired point, either on the gage or the piece of work to which the taper being bored must fit.

The Taper Attachment. — Finishing the taper by the method just described makes necessary a taper reamer

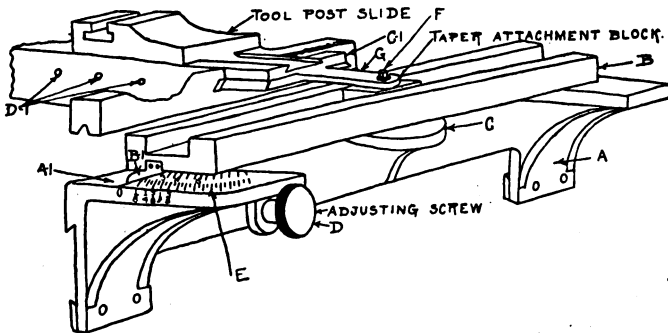

Fig. 137

- A. Taper attachment bracket.
- B. Taper attachment bar.
- C. Swivel bearing.
- D. Adjusting screw.
- E. Graduations.
- F. Connecting bolt.
- G. Cross slide taper attachment extension.

of the proper size. If we have a lathe equipped with a taper attachment, it is not necessary to use such a reamer; it is possible to bore the hole to the required size in the same manner that we did when making the bushing in an earlier lesson. Figure 137 illustrates a taper attachment, and gives the names of the various parts; if you look at the space A-1, you will notice a series of graduations, marked 0, $\frac{1}{8}$ " , $\frac{1}{4}$ " , $\frac{3}{8}$ " , $\frac{1}{2}$ " , etc.; these graduations indicate the amount of taper per foot, which will be

obtained, if the index finger marked *B-1* is set at the point indicating the fractions of an inch shown. A study of these graduations indicates that we may obtain settings in sixteenths of an inch, as well as eighths of an inch.

The method of setting up a taper attachment varies as applied to tools of different design, but the principle involved is the same in all cases. In Fig. 137 is shown a section of a lathe carriage, and we see, by studying the drawing, that the cross slide, carrying the tool post, operates on another slide which sets in the saddle. To operate the taper attachment the slide *C-1* is loosened up so it moves back and forth in the saddle. This loosening may be by means of removing a pin at some point, or slacking off one or more screws; in the particular tool illustrated the small screws *D-1* are slacked off, allowing the sub-slide *C-1* to move freely in the saddle. The gib should be adjusted so the slide moves freely but does not shake. The next step is to move the whole taper attachment into such a position, that it accommodates the carriage movement when taking a cut. Fasten the attachment solidly, connect the sub-base to the taper attachment block, run the carriage back and forth to be sure it operates properly, and the machine is ready for work.

In running a cut with a taper attachment, the worker must be careful to take all backlash out of the connections before starting to work. To do this, set the tool so it just scrapes the surface you wish to cut; now run the carriage back two or three inches, and then run it up to the cutting position; backlash is nothing but the looseness of the parts, which is "*taken up*" as the machinist expresses it, by the movement just described. After taking the roughing cuts, the fitting should be tested with either a gage, or the piece that is to fit the taper being bored, as already described.

On certain occasions a workman finds it necessary to turn a taper to a given number of degrees instead of to a certain amount per foot of length. If we look at point A-1, Fig. 137, we will see that the taper attachment is graduated in degrees and, by setting to these graduations, it is possible to turn work to any angle within the working range of the attachment. The graduations in degrees and fractions of an inch per foot are not always placed at the same end of the attachment; very often the taper per foot graduations are at one end of the attachment, while the degree graduations are at the other. It is not difficult to distinguish between the two sets, however, because the taper per foot graduations appear as $\frac{1}{8}$, $\frac{1}{4}$, etc. each side of the index line, while the degree graduations appear 0, 5, 10, etc. each side of the index; when turning work to an angle, it should be tested, either with a gage or the protractor

QUESTIONS

1. Describe the various lathe tools in common use
2. For what purpose is the centering Y used?
3. Describe the method of using a knurl.
4. Describe the first steps to be observed, when starting to work on a machine with which you are not familiar.
5. Explain and illustrate the process of "centering" a piece of work.
6. How may the centers of a lathe be trued up? Explain the details.
7. How may a lathe be tested to determine whether or not it will turn straight?
8. Describe the process of truing a piece of work in the chuck.
9. Describe the various kinds of fits, commonly used in machine shop practice.

134 PRACTICAL MACHINE SHOP PRACTICE

10. Give a brief explanation of the properties of the U. S. standard thread.
11. Explain the difference between a right and left hand thread.
12. For what purpose, and in what manner is a nut mandrel used?
13. Explain the meaning of the term "taper per foot." What tapers are commonly met in machine shop practice?
14. Describe the possible methods of turning a taper in the lathe.
15. What methods are available for turning internally tapered work?

CHAPTER V

THE LATHE BACKREST. FOLLOW REST. COMPOUND REST. ECCENTRIC TURNING

The Backrest and Follow Rest. — Two pieces of auxiliary equipment for the lathe which we have not considered are the backrest and follow rest; in Fig. 138 we see the backrest mounted in place on the lathe and the method of using it illustrated. The backrest is used by the machinist to support unusually long pieces of work, and for drilling certain classes of work, not conveniently held in a chuck; this latter use is illustrated in the figure, where we see a part of a steam engine governor set up for the purpose of drilling a hole in the end; this hole must run true with the turned part of the spindle: it is easier to obtain a true running hole if the work is revolved and the drill remains stationary, than when the drill revolves and the work remains stationary; hence the reason for using a backrest for doing the job described. To set this job up properly, the piece of work is first centered, faced up and turned to the proper outside diameter; the work is then removed, and the backrest put in position with the jaws slacked back and the cap opened so the work may be returned to the centers; the face plate is now slacked off and a lace leather wrapped around the work, through the face plate slots and around the collar of the face plate as shown in the figure; the backrest cap is now put in position, the clamp nut tightened solidly, and the backrest jaws carefully adjusted by means of the adjusting screws so they set closely, but not solidly against the work. The jaw clamping screws *A* at the back of the rest should now be set up solidly, and a

little oil placed on the work where it runs in the back-rest; the faceplate is now screwed solidly against the spindle shoulder, and the lacing will thus draw the work firmly against the live center, so the footstock center may be withdrawn. The drill is then carried either in

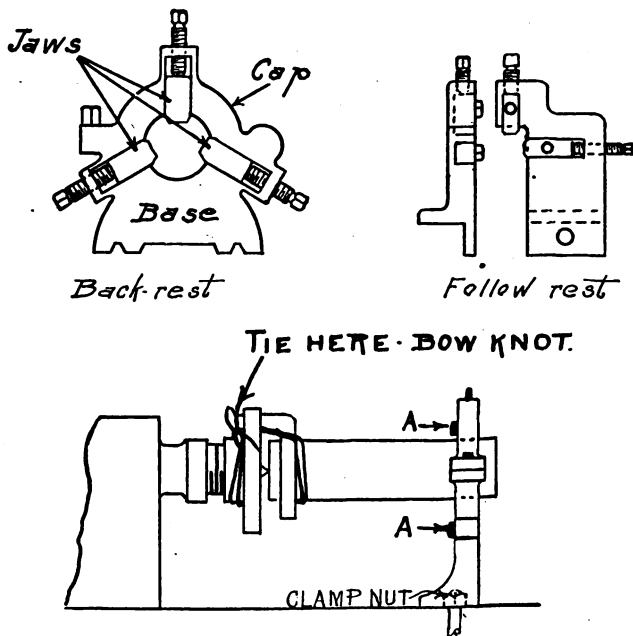

Fig. 138

a drill holder, or in a collet such as is used for drill press work. This collet must fit the taper in the footstock spindle. At times the machinist must do a job of this sort when he has neither a drill holder nor a collet which fits the lathe. The method illustrated in Fig. 139 may be used for supporting the drill on such occasions. Remember that the work must be turned true at the point where the backrest jaws bear on it, regardless of whether

we are supporting a long slender piece for turning, or doing a job similar to that just described. In preparing the work for receiving the backrest jaws, in the case of

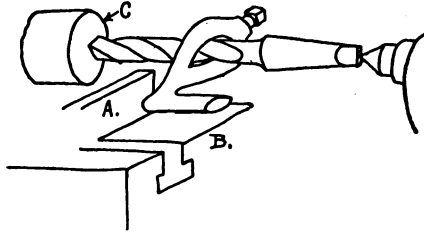

Fig. 139

- A. Tool held in tool post.
- B. Tool post block.
- C. Work.

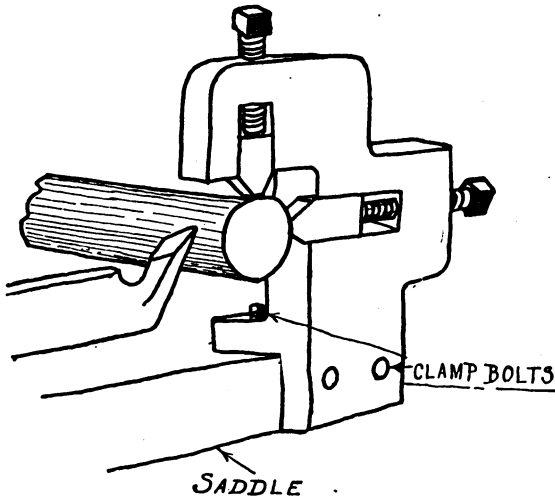

Fig. 140

supporting a long piece of stock, the machinist "spots a place for the backrest jaws by turning just enough stock off to make the work run true at the point where

the backrest jaws are to bear. The rest is then mounted as already described, and the turning to size is done by first roughing out the section between the footstock and backrest, then removing the backrest, turning the piece end for end in the lathe and resetting the backrest on the turned portion of the shaft, then roughing out the

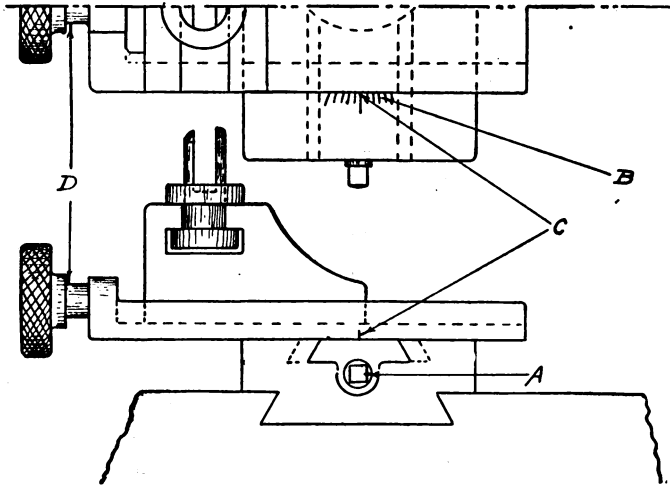

Fig. 141

remaining portion of the same; finishing the shaft to size is a repetition of the process just described. The place first spotted for the backrest jaws should be located about midway the length of the piece to be turned.

In turning a long piece of work such as just described, the follow rest is a much more desirable supporting device than the backrest, because it supports the work at a point very close to the tool, and assures a better cutting action. The manner of placing the follow rest is illustrated in Fig. 140. The workman starts by turning a short section of the end of the shaft, about 2" in length to the diameter which will be produced by taking the

roughing cut; then the follow rest put in place, by clamping it to the saddle as shown in Fig. 140 and adjusting the jaws so they bear closely but not tightly against the turned section of the shaft; put some oil on this bearing and be sure to keep the bearing of the jaws on the work well oiled during turning. Notice that the cutting tool must lead the follow rest jaws when working. Start the cut the same size as the section turned down and run it the full length of the shaft; there will be a short section which cannot be turned because of the position of the dog on the work; usually the workman shifts the piece end for end after each cut, and brings the section to the required diameter. The follow rest must be set for each cut run over the work, and it is of service on straight turned work only.

Angular Turning. — In Fig. 142 we have shown a part known as a bevel gear blank. There is no new process

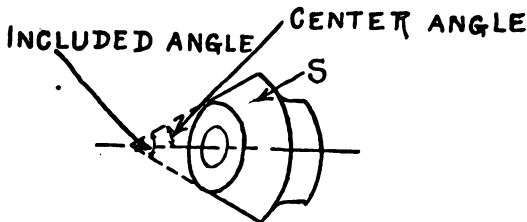

Fig. 142

involved in the making of this piece except the finishing of the surface *S* which introduces what the machinist calls *angular turning*. Figure 141 shows the construction of the compound rest of a modern engine lathe; we notice that the tool block swings on the base; by slacking of the bolt *A* we may move the rest, so that the tool may be made to move at any required angle relative to the center line of the lathe. On face *B* is a set of graduations, and at *C* we have an index mark. The swivel is moved

to the required angle, clamped by means of screw *A* and the turning proceeded with in the usual manner. Be sure the cutting point of the tool is the same height as the center of the lathe, not above or below, because if it is, a true conical surface will not be produced. A point of some importance may be mentioned in connection with the setting of a compound rest for angular turning. The graduations on the rest usually start at zero

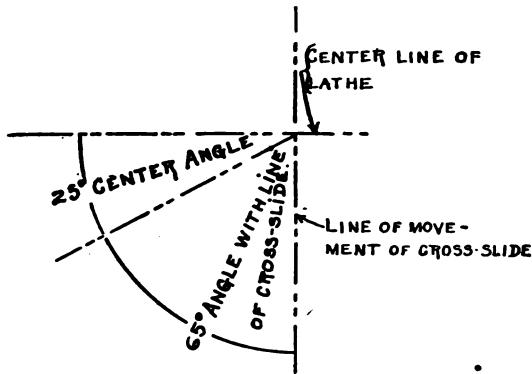

Fig. 143

when the rest is in its normal position, that is the tool when fed by means of the compound rest screw *D*, Fig. 141, will cut at an angle of 90° with the center line of the lathe. On the other hand the angle as given on most drawings is related to the center line of the work. If the workman sets the compound rest so it reads the same number of degrees on the compound rest graduation as called for on the drawing, he will spoil the piece; what must be done under such conditions is to subtract the number of degrees called for on the drawing from 90° which will give us the proper reading on the compound rest. A study of Fig. 143 will make clear the reason for this setting; the movement of the cross feed is at an

angle of 90° with the center line of the lathe. The reading of compound rest graduations is 0 at this point; when the compound rest is set at 90° according to the graduations at *B*, Fig. 141, the movement of the compound rest feed is parallel to the center line of the lathe. The drawing giving an angular measurement from the center of the work is evidently measuring from the center of the lathe; now as we swing the compound rest back to get the desired angle, we are subtracting from the 90° reading of the compound rest, so if we wished to set to turn a piece at an angle of 25° with the center line, the reading on the compound rest graduation would be $90^\circ - 25^\circ = 65^\circ$. The angle between the center line of a piece thus turned and the face is known as the *center angle*, while the angle between the faces is known as the *included angle*.

Eccentric Turning. — A very interesting process in lathe practice is involved in eccentric turning; a job of this sort is shown in Fig. 144. The piece is a part of a milling machine dividing head; eccentric turning always makes necessary the use of two sets of centers in either the work itself, or the mandrel on which the work is mounted when turning. It so happens that for this particular job we must use a mandrel, and, for the sake of the study of the problem, we will assume that we must make the mandrel, before we start work on the piece itself.

In Fig. 144 is shown the mandrel to be used for the job we are discussing. Looking at the drawing of the work we see that the center of the bore of the piece and the center of the larger outside turned portion are $\frac{5}{8}$ " apart. As there is a $\frac{3}{4}$ " hole through the center of the piece, it is evident that the center for turning the larger outside turned surface cannot be placed in the work. On some jobs the centers for all operations can be placed in

142 PRACTICAL MACHINE SHOP PRACTICE

- the piece being machined, in which case no mandrel such as is to be described is necessary. If such be the case, the work is laid out and machined in the same manner described in connection with making the mandrel.

For making the mandrel we select a piece of stock large enough so that we can turn it down to make a driving fit in the bore of the work. This piece should of course be properly centered and faced up, before it is turned; the mandrel should be about three inches longer than the work to be operated on, and it should drive into the work so the piece will be supported about one and one

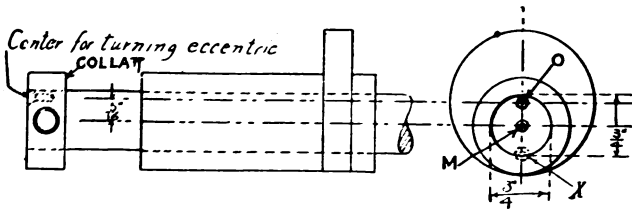

Fig. 144

half inches from each end of the mandrel as illustrated in Fig. 144. Next prepare two collars as illustrated in Fig. 145 having them bored so they are a light driving fit on the ends of the mandrel; drill and tap these collars, using a pointed set screw, the point of which will reach a seat formed in the cylindrical surface of the mandrel, as shown in the dotted lines, Fig. 145, at A. These collars should be mounted on the ends of the mandrel, the set screws tightened firmly, and coloring acid applied to the end faces. Take a center square and draw a diametral line across one end face of collar and mandrel as shown at BC, Fig. 145. Place the mandrel in a V-block on the surface plate, and, with a surface gage set as shown in the dotted lines, so adjust work and surface gage that the point of the surface gage needle will travel along

the line BC as the surface gage is moved over the surface of the plate. Hold the work firmly in the V-block, and, with the surface gage needle unchanged, strike a line across the end as indicated by the surface gage in full lines. These two lines we know to be in the same plane; that is, if we were to cut the mandrel and collars in half on these lines, we would find **both** the lines we have just drawn, lying in the surface we had formed by this process of cutting.

Now leave the surface gage set just as it is, turn the work in the V-block, and with a try-square set the line BC on the end faces of the collars as shown in Fig. 145 B.

We now have a center plane, set perpendicular to the surface plate. With the surface gage, strike another line across each end face of the mandrel as at DE , Figure 145 B.

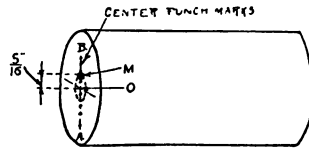

Fig. 144 B

We now have two lines on each end face of the work, one perpendicular to the other. The centers for turning the outside eccentric surface must be $\frac{5}{16}$ " from the centers of the mandrel, and in the same plane; see Fig. 144. To locate these centers, remove the work from the V-block, and place two center punch marks e and f on the line DE ; the distance of these marks from the center of the mandrel is not important, so long as they are located exactly on the line DE . Set a divider to $\frac{5}{16}$ " (which is equal to 0.3125") and with the center punch marks e and f as centers strike two arcs g and h , on each end face of the work. Draw a line tangent to these arcs, as shown at Fig. 145 B. The point where this line crosses the line BC locates the center for turning the eccentric portion of the work. Center punch this intersection, and drill and countersink the centers thus found. The line of the eccentric centers

must be located on the cylindrical face of the mandrel, for purposes of setting work as described later. The placing of this line is done as follows: Set the line *BC* in

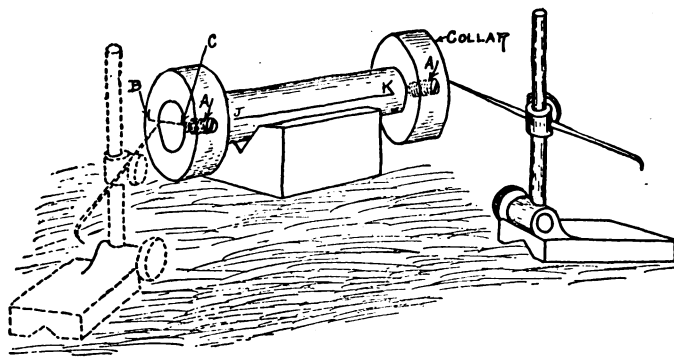

Fig. 145

a horizontal position, by placing the work in a V-block as shown in Fig. 145 and using the surface gage; with the gage unchanged so far as the setting of the needle is concerned, hold the work firmly in position and strike the line *JK* on the surface of the mandrel. The mandrel surface should be treated with coloring acid before it is set up for the layout of this line. This line should be scored quite heavily by use of a box square and scriber, after it has been laid out, so it will not be removed by being driven in and out of the work.

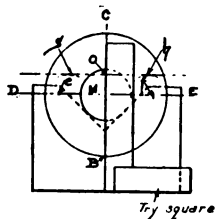

Fig. 145 B

The mandrel is now ready for use, but each piece of work must be properly laid out before we can mount it on the mandrel. Figure 144 B shows the blank from which the piece is to be made; center this piece just as though it were to be turned in the ordinary manner, but do not drill or countersink the work. With a divider,

swing a circle from the center found, the radius of which is equal to the desired distance between the center of the bore and the center of the eccentric turned portion; this will be $\frac{5}{16}$ " as shown in Fig. 144. Now with a straight edge draw a line through the center of the work as indicated at *AB*, Fig. 144 *B*, and center punch it as indicated in the figure. Each blank must be laid out in this manner, before any drilling is started. Set the work up in the chuck truing it by means of the center indicator shown in Fig. 66, so that the center *M*, Fig. 144 *B*, runs true, and proceed to drill and ream each blank.

To mount the work on the mandrel, remove the collar from the end of the mandrel, and drive it into the work, so that the line *AB*, Fig. 144 *B*, on the end face of the work, coincides with the index line, *JK*, Fig. 145, on the mandrel surface. Replace the collar, tighten the set screw solidly, and proceed with the turning and facing of the body of the work, mounting the arbor on the lathe centers by means of the centers *M*, Fig. 144. Face up the eccentric while thus mounted. The mandrel should now be shifted on the lathe centers to center *O*, Fig. 144, and the eccentric turned.

In mounting the drilled blank on the mandrel, it must be so placed that the true center of the piece, *O*, Fig. 144 *B* and 144, coincides with the offset center of the mandrel, as shown in Fig. 144. If the work is mounted so that the center *O* of the work stands as indicated by the dotted center *X*, Fig. 144, the job will be spoiled in doing the eccentric turning, as all the stock for making the eccentric will be turned off, because the center of formation of the eccentric is 180° from the center of the stock.

QUESTIONS

1. For what purpose are the backrest and follow rest used on the lathe?
2. Briefly describe the method of mounting a piece of work in the backrest.
3. Explain the necessary "set up" for angular turning on the engine lathe.
4. What is meant by "eccentric turning"?
5. Present the essential steps in preparing a piece of work for eccentric turning.
6. Describe the plan you would follow in boring and turning a large eccentric piece.

CHAPTER VI

THE DRILLER OR DRILL PRESS

BEFORE taking up the study of the machine itself, we will look over some of the more common tools used in connection with the driller. At *A* and *B*, Fig. 146, we see illustrations of the collet. There are two types of collets, the one illustrated at *A* being known as a long collet, while that at *B* is known as a short collet or sleeve.

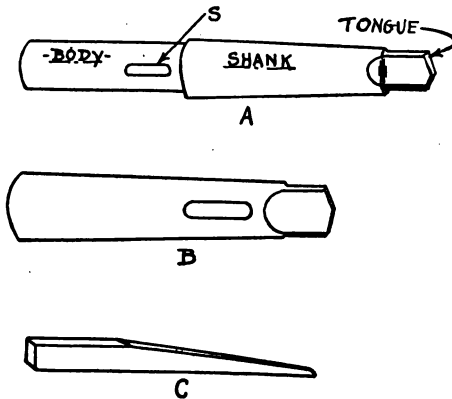

Fig. 146

Short collets are also often designated as sockets. At *C*, Fig. 146, is illustrated a key, also known as a drift; this tool is used in the collet slot *S* for the purpose of removing a drill. The key is inserted in the slot, and a slight tap on the large end will throw the drill from the collet.

Figure 146 *B*, drawing *D*, shows a small hand chuck; this piece of equipment is used to hold small drills. It is tightened solidly by means of the wrench shown at *E*. Figure

148 PRACTICAL MACHINE SHOP PRACTICE

146 B, drawing F, shows the counterbore; at F we have the solid type, and at G, Fig. 146 B, the inserted cutter type. This tool is used for spotting off faced "bosses" on

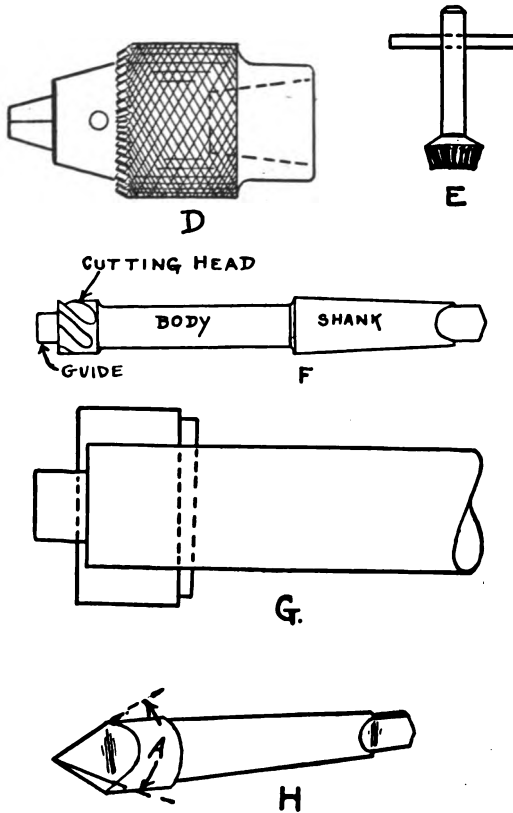

Fig. 146 B

which bolt heads are to rest, when the parts of a machine are assembled. In Fig. 81, showing a section of a bearing cap, we have an illustration of its use in truing surface B so the nut will bear squarely on the casting. The guide

of the counterbore fits in the drilled hole, and serves to steady the tool during the cutting operation. A little oil should be used on the guide, unless some kind of a lubricant is used in the cutting process, because if the tool is used dry, the work may be damaged. The solid

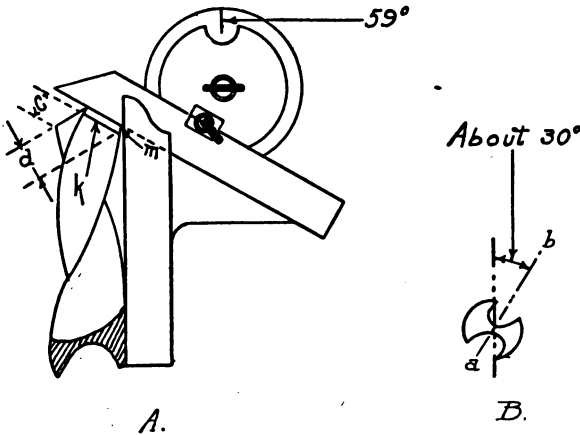

Fig. 147

counterbore is used for the smaller sizes of this tool, and the inserted cutter type for the larger sizes.

The screw head countersink is illustrated in Fig. 146 *B* at *H*; the angle *A* on this tool is made 82° for wood screws and 72° for machine screws. An effort is being made at the present time to introduce the 82° angle for the heads of both machine and wood screws, and some manufacturers are following this practice.

Grinding a Twist Drill. — The workman should see that a drill is properly ground before it is placed in use; it must be central, at the proper angle, and have correct clearance. In Fig. 147 at *A* the protractor is set at the proper angle for grinding the cutting lip of a drill which is 59° . In grinding, one should test the drill repeatedly

to see that the angle is correct; the distances c and d should be measured with a scale; these distances must be kept equal. The clearance angle should be noted, as indicated by the short line ab , Fig. 147 at B , formed by the web of the drill when it is ground; a workman does not

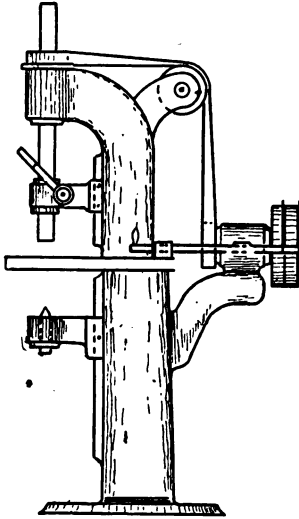

Fig. 148

measure this angle with a protractor, but depends on his judgment as a guide in determining the proper clearance. When looked at from the side, as indicated in Fig. 147 A , the back of the lip at k should set back from the cutting point m , so the drill may cut freely.

The Drilling Machine. —

The driller is not as general in its application in the machine shop as some other tools, but it is a very necessary piece of equipment. Figure 148 illustrates a "sensitive" driller; the term sensitive is applied to this tool because it is used for small work, and the feed

is by means of a hand lever, without the use of gearing. This tool may be used to advantage for drilling small holes, ranging in diameter from $\frac{1}{32}$ " to about $\frac{5}{16}$ "; the work is handled in exactly the same way on this tool as on the larger tool to be described later, except that the detail of work is more simple. There is usually no necessity for clamping the work on a sensitive driller.

Figure 149 illustrates a heavier tool known as an upright driller; there are various sizes of this tool on the market, but the size most commonly found in the machine shop will drill holes ranging from $\frac{1}{4}$ " to about $1\frac{1}{4}$ "

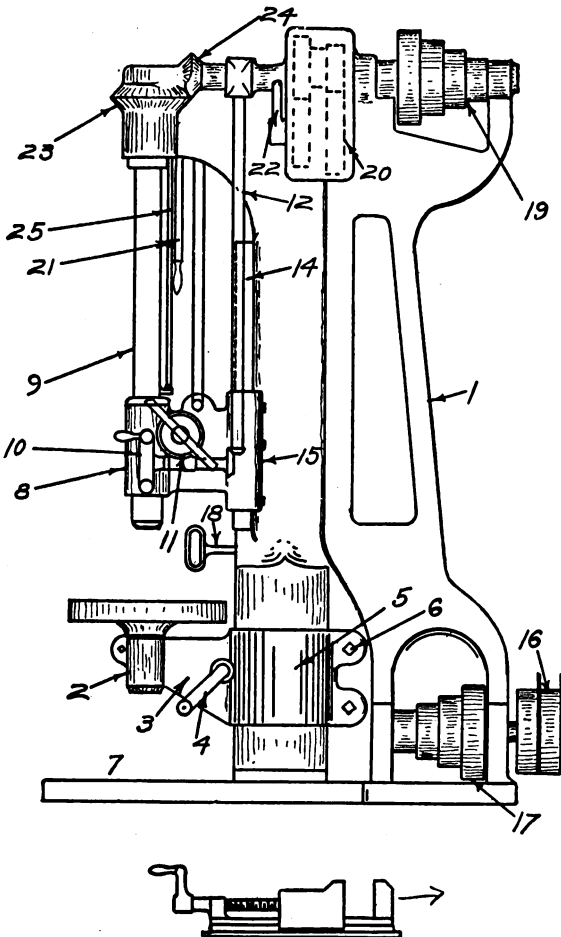

Fig. 149

- | | |
|--|--|
| 1. Column bracket. | 14. Head bearing face. |
| 2. Table bearing. | 15. Head bearing. |
| 3. Table bracket. | 16. Tight and loose driving pulleys. |
| 4. Table elevating handle. | 17. Main driving cone pulley. |
| 5. Table sleeve. | 18. Shipper, starts and stops the machine. |
| 6. Table sleeve clamp bolt. | 19. Spindle cone pulley. |
| 8. Head sleeve. | 20. Back gears. |
| 9. Spindle. | 21. Back gear clutch lever. |
| 10. Feed handwheel. | 22. Back gear shifting handle. |
| 11. Power feed worm wheel, clutch and quick return handle. | 23 and 24. Spindle driving gears. |
| 12. Power feed drive shaft. | 25. Spindle counterweight chain. |

152 PRACTICAL MACHINE SHOP PRACTICE

diameter. Oil the machine, learn to handle all parts, throw back gears in and out, and become generally familiar with the movement of parts before starting a job.

The tools used in the driller have been discussed in this and other chapters; these are the reamer drill, tap

SCORE LEADING DRILL TO PROPER POSITION

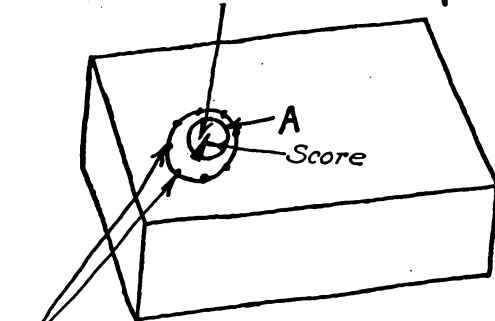

CENTER PUNCH MARKS OF LAYOUT

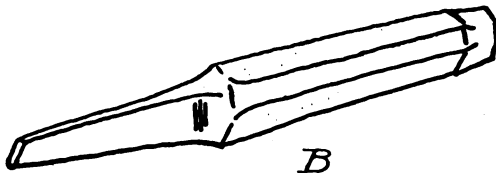

Fig. 150

drill, pipe tap drill, counterbore and countersink; for sizes of tap drill and pipe tap drills, see tables XI and XIV.

As a study in working on a driller, let us assume that we are to drill a hole in a flat piece of stock, as illustrated in Fig. 150. The work should be laid out by means of the surface gage, scale, divider and center punch used as previously illustrated. When drilling is started, the drill is apt to run away from the layout as illustrated at A,

and the drawing chisel shown in Fig. 150 *B* must be used to lead the drill back to the proper position. The method of using this chisel is illustrated in the figure mentioned, where a small score is shown cut down the side of the drill cut, towards which we wish to lead the drill; this

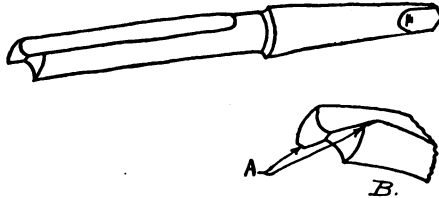

Fig. 151

cut is extended nearly, but not quite to the bottom of the cone made in starting the drill. The drill should now be started cutting again and just enough stock cut out to remove the drawing score made by the chisel; the work should now be examined, and if the drill is not coming true to the layout, it must be drawn again. The drill must be true to the layout before the hole is deep enough

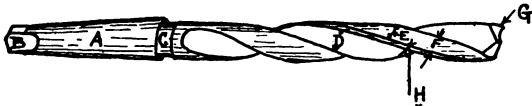

Fig. 152

- | | |
|------------|-----------------|
| A. Shank. | E. Clearance. |
| B. Tongue. | F. Land. |
| C. Neck. | G. Cutting lip. |
| D. Groove. | H. Sizing land. |

to reach the size of the drill, as no drawing can be done after the full size has been reached. In starting the job, be sure that a drill is selected which will permit the proper finishing of the hole, that is reaming, tapping, for a standard thread, or tapping for a pipe thread.

When working, the drill must be lubricated, either with oil, or one of the lubricating mediums much used in

machine shop practice; oil should not be used on brass or cast iron, but the prepared lubricants work quite satisfactorily on these materials, as well as on steel and wrought iron; brass and cast iron are very often drilled dry, however. The standard twist drill does not cut well in brass so a "pod" drill, Fig. 151, is very often used to advantage. The twist drill may be made to work satisfactorily in brass, by grinding the lip slightly as illustrated in Fig. 151 B. This grinding prevents the

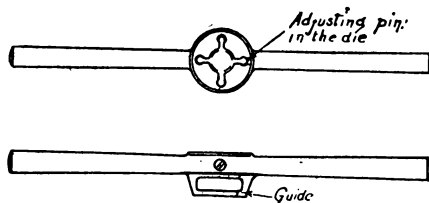

Fig. 153

digging in or "biting" which is usually encountered when the twist drill is worked in brass.

Figure 152 gives the names of the various parts of a standard twist drill. All drills are not fitted with the same size of shank, and table XV shows the relative proportions of the various sized shanks used in practice.

In pipe fitting a workman does not use a U. S. standard thread but a special standard, adapted particularly to pipe work. The table XIV presents the properties of this standard. All tools for pipe work are tapered approximately $\frac{3}{4}$ " per foot. For cutting threads on pipe a die is used, mounted in a die stock as illustrated in Fig. 153. For threading the couplings, elbows, etc. a tap must be used, the hole having first been drilled with a pipe tap drill of a size corresponding to that given in the table.

Pipe is always measured by the size of the hole in it; the outside diameter of a pipe with a half inch hole is

quite a little over $\frac{1}{2}$ " , and the hole in the fitting must be large enough to accommodate the outside diameter; this accounts for the fact that a $\frac{1}{2}$ " pipe tap drill is considerably over $\frac{1}{2}$ " in diameter as will be noticed when the table of pipe standards is studied. When using taps on any kind of material always lubricate them.

On the driller the learner should have a sufficient number of jobs in laying out, reamer, tap, pipe tap and cylindrical work to become perfectly familiar with all the

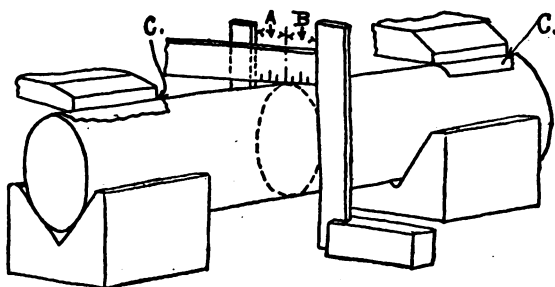

Fig. 154

steps involved. The greater portion of the work done on the driller is "plane" or flat surface work. The drilling of cylindrical work is of sufficiently frequent occurrence, however, to make the process worth studying. A job of drilling a cylindrical piece requires the use of V-blocks as shown in Fig. 154 where the manner of setting up the work is illustrated. One must be careful that the distance *A* from one extremity of the diameter to the center of the layout is exactly the same as the distance *B* from the other extremity to the center. These measurements are made by using the try-square and steel rule, as shown in the full and dotted lines, clamping the piece lightly in the V-blocks, and rolling it slightly with the hands in order to get the desired setting.

When the proper position has been found, clamp the

work solidly in place, being sure the clamp is over the block, so the work is not bent when tightening the clamp. A word of caution should be observed here with reference to clamping; never clamp a piece unless it is well supported beneath the clamp. Many beginners are quite careless in this connection, and a great deal of work is spoiled by improper clamping. The rule of having a solid support beneath the point where a clamp bears holds true not only on a drill press, but on all other machines as well.

Use of Vise on Drill Press. — Just below the illustration of the drill press, Fig. 149, is shown a vise, also called a "shoe." This device is very convenient for much work on the drill press, in that it often eliminates the necessity for clamping. For example the cylindrical piece just described can be held very easily in the vise, if the work is not too large. When setting work in the vise, or clamping it on the table, the operator should be sure that there is a space between the lower face of the work and the surface of the machine table, so the drill may pass completely through the work without cutting into the table. Parallel pieces of cast iron or steel are used for such purposes; these pieces are known as "parallels" in the shop.

QUESTIONS

1. What is the purpose of the collet as used on the drill press?
2. Briefly describe the more common tools used on the drill press.
3. Present the essential features to be observed in grinding a twist drill.
4. Describe the process of starting a drill true to the "layout."
5. Give a brief description of the "set up" for drilling cylindrical work.

CHAPTER VII

THE SHAPER

THE shaper, shown in Fig. 155, is a type of machine tool used for producing flat or "plane" surfaces. It is really a small planer, the difference between the planer and shaper being one of construction rather than a difference in the class of work for which the tool is used. The shaper is so built that the work remains stationary, and the tool passes over it in cutting; on the planer the work is clamped to a moving part, and passes beneath the cutting tool. The shaper is used for machining small parts, while the planer is used for heavier work.

In Fig. 156 are shown the more common tools used on the shaper; shaper and planer tools are similar, the former being smaller than the latter, that they may be adapted to the more intricate work for which they are used. Notice particularly the angles of the cutting parts of these planing tools, and compare them with those used on the lathe. It is evident that the clearance angles are not as large on planer as on lathe tools; the planer requires a more stumpy tool than the lathe, in order to avoid the tendency to dig into the work when cutting. The beginner should practice grinding these tools, and hold to the smaller clearance angles if he wishes to get the best results from the shaper. These clearance angles are not usually measured, the experienced workman depending on his judgment in determining the correctness of the angles. The beginner must, however, study these clearances with care, in order that he may accustom the eye to the relative angles of the various tools.

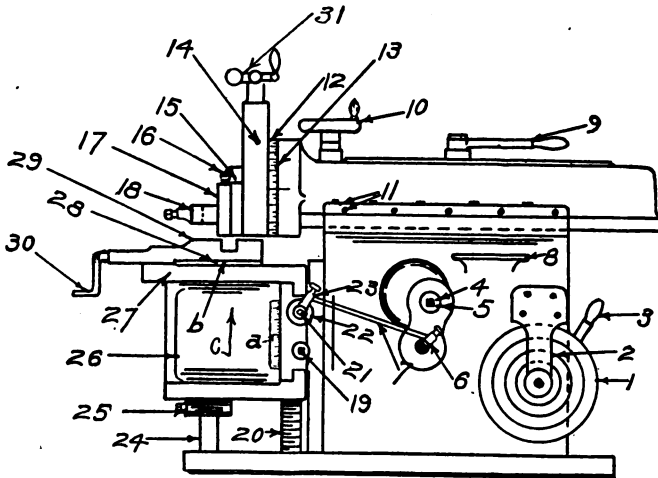

Fig. 155

- | | |
|--|---|
| 1. Main driving cone pulley. | 13. Graduations; in degrees. |
| 2. Cone pulley bracket. | 14. Head slide. |
| 3. Back gear shifting lever; shift lock nut in cone if necessary before throwing in back gears. | 15. Clapper box. |
| 4. Stroke adjusting shaft. | 16. Clapper box clamp bolt. |
| 5. Stroke adjusting shaft lock nut; always slack this off when stroke is adjusted, and tighten after adjustment is made. | 17. Tool post block. |
| 6. Feed crank. | 18. Tool post. |
| 7. Feed rod. | 19. Cross rail elevating shaft. |
| 8. Tool shelf. | 20. Cross rail elevating screw. |
| 9. Clamping lever; slack off to adjust ram; tighten after adjustment is made. | 21. Cross feed screw. |
| 10. Ram-adjusting handwheel. | 22. Feed gear. |
| 11. Gibs; top and side. | 23. Feed gear ratchet. |
| 12. Swivel. | 24. Table brace. |
| | 25. Table brace clamp. |
| | 26. Table swivel. |
| | 27. Table work surface. |
| | 28. Shoe or vise base. The vise is made up of a base and solid jaw. |
| | 29. Vise sliding jaw. |
| | 30. Vise clamping handle. |
| | 31. Head slide handle. |

After studying the tools the next step is the study of the machine itself, and Fig. 155 presents a drawing of a shaper. Study the names of the parts, learn the function of each and manipulate the machine in detail, shift-

ing the speeds, throwing feed levers in and out, setting back gears, etc., till you are sure that you have full control of it. The job we are about to study is the machin-

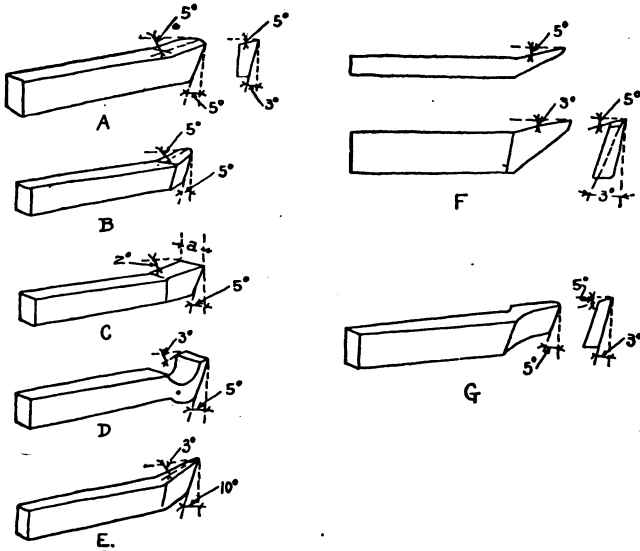

Fig. 156

The diamond point used on the shaper is shown in Fig. 107.

A. Roughing tool; this is the right-hand form. The tool is made in both right- and left-hand form.

B. Round-nosed tool.

C. Square-nosed tool; width at a may be made any desired dimension.

D. Goose-neck tool. The goose-neck may be made slight as shown in the drawing or it may be quite long. The goose-neck form is useful on tools having a broad cutting edge, as it prevents chattering.

E and F. Views of a right-hand down cutting side tool. This tool is made in both right- and left-hand form.

G. Right-hand surfacing side tool. This tool is made in both right- and left-hand form.

ing of a driving arm block for the shaper itself. This piece is made of steel, and must be accurately machined; we recall that mention was made of the necessity for lubrication when drilling steel. Lubrication of the cut-

ting tool is unnecessary in planing, except on parting operations, because the cutting action is not constant.

A study of the shaper will show that after cutting the tool must return to its first position and take another cut, so the tool has a rest, as it were, after each cut. In other words the cutting action is intermittent, and the heat generated in taking a cut passes out of the tool during the time it is returning from the end of the cut to the starting point. Continuous cutting operations in steel, such as drilling, turning, and milling are usually lubricated, but intermittent operations are not lubricated.

The piece which is to be planed, in the present case, will be held in the vise. The vise is set on the knee, being sure that there is no dirt on either of the faces which come together; the workman should also be careful that there are no spots that have been nicked on the surface of the knee or vise. If there are, a smooth file should be used to remove them. Look at the index mark at *a* on the knee and at *b* on the vise, Fig. 155. The knee in some designs is so constructed that it can be swung as indicated by the arrow at *c* to either right or left. The vise can also be moved about on the base; be sure that the index lines on these parts are set true to the zero of the graduations, and tighten all binding bolts, on both the knee and vise.

It is assumed that the piece on which we are to work is a piece of rough stock, cut from a machine steel bar. The stock is set on a parallel piece, so the surface on which the cutting is to be done stands above the face of the vise. The tool is caught short in the tool post, the knee binding bolts slacked off, and the knee raised so the surface of the work is just low enough to clear the under surface of the ram, as it passes back and forth; the knee bolts are tightened again, and the machine is ready for work. The stroke must be adjusted, and the ram set in

the proper position to pass the tool over the work, giving about $\frac{1}{2}$ " leeway at each end, for the stroke to extend over the actual length of the work.

Tighten up any loose adjusting screws or bolts, and be sure the machine is properly oiled. Use a lead ham-

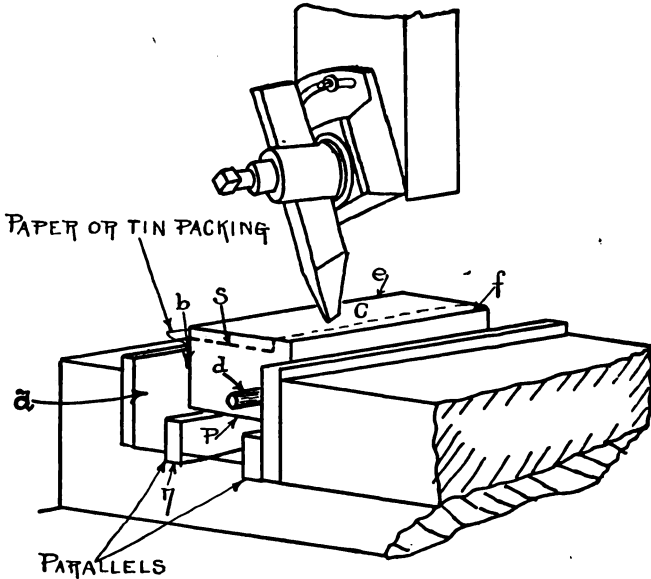

Fig. 157

mer, drive the work down firmly on the parallel strip, not striking too heavily but using a light tapping blow so the parallel is held firmly in place by the work. Run a light cut over the work, using the automatic feed. The work is now removed from the vise, all dirt brushed from the shoe and the work with the hand, and the finished surface we have just planed placed against the solid jaw *a* of the vise. Surface *c* is now to be planed square with surface *b*. The "set up" is shown in Fig. 157

where note the small round bar used at *d*; this is necessary in order that the finished face may be forced squarely back against the solid jaw of the vise. Run a light cut over surface *c* being careful that too much stock is not removed, thus spoiling the work.

Remove the work from the vise and test it with a try-square. We may find the two surfaces *b* and *c* accurately true but for the sake of study we will assume that the square touches at *e*, Fig. 157, and does not touch at *f*. We must therefore tip the work in the vise so the cut will remove more stock from surface at *e* than at *f*. This is done by carefully folding a piece of newspaper so it will lay along the top of the vise jaw and extend down about one eighth inch. If the work is out a great deal, several thicknesses of paper should be used as mentioned, or a piece of tin may be bent and used as described. Set the work up in the vise again and run another light cut; remove the work and test; this operation must be repeated until the work is planed square. This paper or tin used as described is known as packing, and when the correct amount has been determined it is used in the same position as each remaining face of the work is planed.

The process of placing packing as described is spoken of as "shimming" the work. Be sure to drive the work down on the parallel at each setting, and always see that there are no irregular places such as dents and burrs on the vise jaws. If there are remove them with either a file or a scraper, or, if the vise jaws are hardened, use an oil stone.

If the work were out of true at *f* instead of at *e*, Fig. 157, the packing should be placed at the bottom of the work, instead of at the top so as to throw the work in the opposite direction, and thus remove the stock at *f* instead of at *e*. The roughing being done we are ready

to take the finishing cuts. In doing this, run a surface cut over the face *b*, Fig. 157. In looking at the drawing of the block, Fig. 157 *B*, one notices two ribs extending at *g* and *h*. We are now ready to plane the block down to make these ribs. The work must be laid out on the end so that the workman has a guide as indicated in Fig. 157. at *s*. Place the block in the vise, so the surface just planed sets against the solid jaw. Set in the packing, and run a light cut; test to be sure the work is square, and shim, if necessary, in order to bring within the required limits of accuracy. A

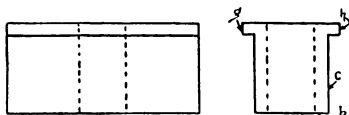

Fig. 157 B

number of surface cuts must now be run, that the stock may be removed to form the rib. The depth gage is used as in Fig. 61 in making the necessary measurements.

After the surface has been cut away, the rib must be squared up. Notice on the shaper head a tool post block, and a clapper box. The tool block is free to lift as the tool returns from the cut, and the clapper box can be swung to right and left. The operation to be carried out is known as down cutting, and a right hand down cutting side tool is used for this work. Whenever down cutting is done, it is necessary to swing the clapper box so the tool will lift free from the work on the return stroke. This is necessary as the tool will mar the work badly if this detail is neglected. One can easily tell whether or not the clapper box has been swung in the proper direction by bringing the tool against the work lightly and trying to lift it. If the box has been moved correctly, the tool will swing away from the face to be cut. If it has been moved in the wrong direction the tool will draw into the work. The proper way to set the tool in the post and to grind the cutting point may

be seen in the illustration, Fig. 157. The rib is finished to size by working to the layout, and measuring the finished dimension with an outside caliper. Be careful not to cut into the finished surface *s* with the side tool when taking the various cuts. The tool should just scrape the surface as the cut is picked up.

To finish the block to proper width it is turned over in the vise, so that surface *P* is uppermost and the operations described for surface *C* are repeated. In finishing this latter surface, the outside caliper is used to determine the finished dimension of width, and the workman should be careful in setting the cuts that too much stock is not removed when working for the finished size. The measuring should always be done before the cut has been run all the way across the surface, as this saves time, and prevents spoiling the work. By setting the parallel a slight distance away from the solid jaw of the vise, the outside caliper can be used when the cut has been run only a slight distance on the work.

The ends of the block are finished by setting the vise in a position such that "down cuts" may be run on them, using a down cutting side tool; a square should be used for testing the accuracy of the work when planing the ends. All surface cuts on this job are taken with a diamond point, and other cuts, with down cutting side tools.

Use of Centers on the Shaper. — The two attachments most used on the shaper are the vise and centers. The centers are illustrated in Fig. 158. This attachment is used for planing machine parts which must be worked true about a center, but which are of such a form that they cannot be turned on a lathe. This same type of attachment is used on the planer for certain jobs, as well as on the shaper. All statements made relative to the use of centers on the shaper apply when they are used on the planer.

The centers are mounted on the knee when in use, as illustrated in Fig. 158. Be sure there is no dirt on the under face of the base, nor on the knee. Slide the footstock up, so the footstock and headstock centers just touch; the purpose of this operation is to find out whether or not the centers are in line. If they are not, they must be trued up, if accurate work is expected. Truing the

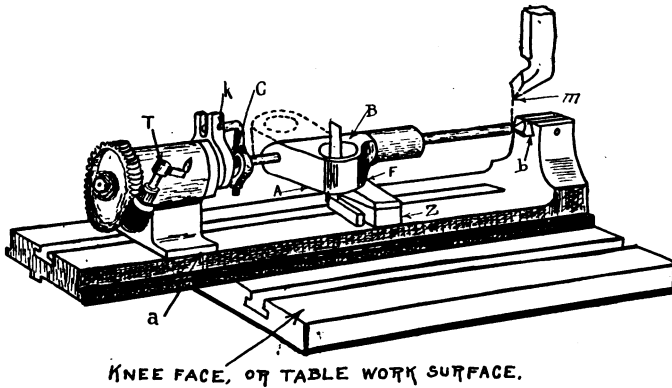

Fig. 158

centers of the shaper may involve grinding the centers, and planing all the base faces of the parts, so it should not be started without authority from the party in charge of your work. The job is usually turned over to the tool room, when truing does become necessary.

When the test mentioned is made, it is sometimes found that one center is slightly lower than the other. This fault may be remedied by placing a shim beneath point *a*, Fig. 158, to raise center *C* or by putting a shim beneath the footstock center at *b*, depending on which center should be raised.

As a typical center planing job, the piece shown in Fig. 158 *B* will be used. This is part of a valve gear for a steam engine; the two faces *A* and *B* as well as

surface *C* must be true about the center hole. Further surfaces *A* and *B* must be true with center of hole *H*. Before the work is taken to the shaper, the holes mentioned must be drilled and reamed, the ends faced, and section *S* turned to the correct size. Start the job by planing surface *C*. Notice at *T*, Fig. 158, there is mounted a circular feeding attachment for use when doing such jobs as we have in hand. The work is mounted on a mandrel, a dog placed in position, and the tool set so the cutting point stands directly over the line of the centers as shown in Fig. 158 at *m*. Such a setting assures a movement of the tool along a radial line of the surface being planed, when an adjustment for cut is made.

Run the tool up out of the way and clamp the gib screws on the saddle so the cross feed cannot be used. The feeding on this job is done entirely by means of the handle *T* through the medium of the worm and worm wheel. Oil the centers, see that the centers in the mandrel are clean, and place the work in the position shown in Fig. 158. Be sure to tighten the set screw *k* on the tail of the dog, so there may be no play while the cut is being taken. Run the tool down, taking light cuts, until the desired depth of chip is obtained, then start the feed by turning the feed handle *T*, in the proper direction to pass the work beneath the cutting tool. The feeding movement is best made when the tool is on the return stroke. After the cut has been run over, the operation is repeated until the work has been reduced to the required size, which in the present case is determined by the turned section at *S*. The operator brings the tool down, until it just touches this surface, and runs a finishing cut. The stroke of the shaper should be set to cover the surface on which planing is to be done; it is not necessary that the stroke be long enough to run the whole length of the work.

The next step on this job is the planing of the two faces *A* and *B* central with hole *D* and perpendicular to hole *H*. Set the work up as in Fig. 158 using a try-square as illustrated, and adjust by means of handle *T* till the inside surface of hole stands square. Place a pair of parallel wedges as shown at *Z* to prevent the work from moving while the tool is cutting. Drive these wedges in place firmly, but not hard enough to spring the work; keep them tight during the cutting operation, because the jar of the tool is apt to loosen them, and spoil the work. It may be necessary to place "shimming" at some point between the surface of work and wedge parallel to prevent springing. If parallel does not come up true all along the surface do not force it up, but place shims to fill any space. Make the necessary adjustments to permit the use of the shaper cross feed, and run a light cut over the surface. Let the tool remain in position after running this cut; do not raise or lower it. Remove the dog from the work, and turn the work to the position indicated by the dotted lines, placing parallel wedges as before. It is not necessary to use the try-square for this setting, because the surface *B* being planed square with the hole *H* becomes a setting surface. As the parallel wedges are driven up closely, the work will revolve on the centers, and true itself in the desired position. Let the tool run over surface *A*. Now since surface *A* and surface *B* have been planed with a tool setting the same distance from the center of the hole *D*, it is evident that these surfaces are central with the hole.

The cuts which have been taken on the surfaces mentioned should have removed as little stock as possible; just enough to produce true surfaces. The try-square should now be used to be sure that the work face is accurately true with the inside surface of the hole. If it is not, the workman must resort to packing beneath the

work, so that it may be moved slightly in the proper direction to produce the necessary corrections. The packing is used between the face of the wedge parallel, and the work, as indicated at *F*, Fig. 158.

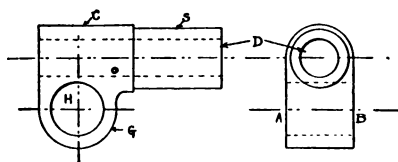

Fig. 158 B

Successive cuts should be run with a set tool, to bring the work to the required size. To determine the size, as the various cuts are started, use an outside caliper, for measuring; run a cut about $\frac{1}{16}$ " along surface, then move the tool away leaving it in position so far as vertical

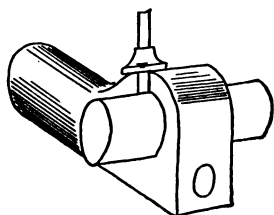

Fig. 159

movement is concerned, turn the work over, and run the cut along the other surface about $\frac{1}{16}$ ". These small planed surfaces may be measured with the caliper, and if too much stock has been removed, the surface which has been planed is not large enough to cause serious damage to the piece. Whenever planing on centers, the size should always be tested on opposite faces, regardless of the number of finished faces which the piece may have. For example, the size on a hexagonal nut is determined in the same manner as just described in detail. After the proper size chip is started, it is carried around all six faces of the nut.

The last planing job on this piece of work consists of truing the surface *G*, Fig. 158 *B*, radially about the center

of the hole *H*. There is no new step involved here, except the determination of the size of the work. For planing the work should be mounted on a mandrel, placed in hole *H*, and operations carried on in the same manner as described in connection with planing surface *C*. To determine the size of the work, a depth gage may be used as shown in Fig. 159. Only a small portion of the surface should be spotted off for measuring purposes, in order that the work may not be spoiled, should an adjustment of the chip prove necessary. The drawing of such a piece of work as we are studying gives the finished dimension of surface *G*, Fig. 158 *B* from the center of the hole *H*. In reading the depth gage, to determine the size, the workman must not forget to consider the radius of the mandrel on which the work is mounted.

Keyway Cutting.— A job for which the shaper is used a great deal is the cutting of keyways, as shown in Fig. 160. In this class of work it is important that the keyway shall be located so that the faces *A* and *B* are equally distant from the center of the shaft. Before starting work on the shaper, holes must be drilled as shown in the figure. These holes serve as starting and stopping points for the tool, and are always necessary when doing a job of this sort. They should be drilled as described in the chapter on drill press work, in connection with drilling cylindrical pieces. It is not necessary for the holes to pass through the shaft; they should be drilled just deep enough to allow the full size of the drill to reach a point about $\frac{1}{32}$ " below the bottom of the keyway.

The work should be laid out, and set up in the shaper vise shown in Fig. 155. The keyway must be located equally distant from the faces of the vise, and this "set up" can be very easily made by using the hermaphrodite caliper as shown in the full and dotted lines Fig. 160,

and calipering from the sides of the layout to the vise faces. The shaft should be adjusted until these measurements are equal. The tools used for cutting this keyway are shown at A-1 and B-1, Fig. 160. A-1 is a roughing tool, and is about $\frac{1}{8}$ " narrower than the finishing tool. Notice that the edges of this tool are rounded

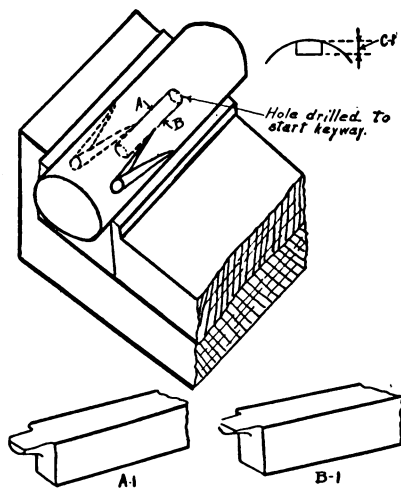

Fig. 160

slightly, so it may better sustain the heavy stresses of the roughing cut. The tool is set vertically in the tool post, and the work adjusted so the tool stands as nearly central over the keyway layout, as one can judge, without making measurements. The stroke of the machine is adjusted in such a way that the tool just drops into the holes at the ends of the stroke. These holes are known as clearance holes. Notice the wedges placed at A 161 to prevent the tool from lifting; it is necessary to block the tool in this manner on such work as keyway cutting, in order to prevent it from lifting on the return stroke,

and thus fail to cut properly. The wedging of a tool as shown is known as "anchoring" when spoken of in the shop. The roughing cut should be run down so the depth of the keyway in the shaft is equal to one half the thickness of the key, measured as indicated at C-1, Fig. 160. Measurement may be made either with a depth gage or by using a steel rule.

Following the roughing cut, the finishing tool is put in place, and centered carefully to the keyway layout.

The finishing cut is then run down to the desired depth. Keyways may be cut by setting the shaft on V-blocks, the same as described in connection with the drilling of a cylindrical piece. If the job is handled in this manner, the work of setting up is identical with that described in the text dealing with drill press work.

A great many jobs of a special nature are done on the shaper, but the fundamental principles of practically all shaper work are presented in connection with the jobs just discussed.

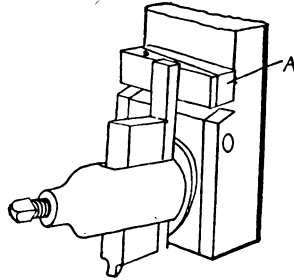

Fig. 161

Keyway tool setting. Wedges at A are called anchor wedges; a short bolt is sometimes used back of the tool instead of these wedges.

QUESTIONS

1. For what class of work is the shaper commonly used?
2. Describe the more common tools used on the shaper.
3. What is the essential difference between lathe and planer tools?
4. What is meant by the term "shimming" as applied to planer practice, and why is it used?

172 PRACTICAL MACHINE SHOP PRACTICE

5. For what purpose are the centers used on the shaper? Why are they necessary?
6. Give a brief description of the "set up" for cutting a key-way on the shaper.
7. What is meant by "anchoring a tool" and why is it necessary?

CHAPTER VIII

THE SLOTTER

THE slotter, also known as the spliner, is illustrated in Fig. 162. This machine is used, in the machine shop, for such work as is not conveniently done on the planer or shaper. The movement of the tool is similar to that noticed in the study of the shaper, except that in the shaper the cutting tool travels horizontally while in the slotter it moves vertically.

Figure 163 illustrates a typical slotter job; the piece of work is a strap used on a steam engine connecting rod. The work is finished on the surfaces *A*, *B*, *C* and *D* before it comes to the slotter; this work is done on the planer. The finishing of surfaces *E*, *F* and *G* is most economically done on the slotter. The first step in doing this job is to set up the knee as illustrated in Fig. 164. This must be set so it will serve as a guide in placing the work, hence the surface of the knee must be true with the travel of the table, when it is moved by means of the feed screw.

To do this, first see that the graduations on the table base at 14, Fig. 162, are set true to the index marks. All slotters are not graduated as mentioned, but the step suggested must not be neglected in the "set up," if there are such graduations. Set the knee on the table as nearly true to the line of travel as can be judged by the eye, and clamp it lightly in place. Set a tool in the tool post, and bring it into position as shown, in Fig. 164, drawing up to the face of the knee by means of the lengthwise feed screw, so that the steel rule, *D*, when swung back and

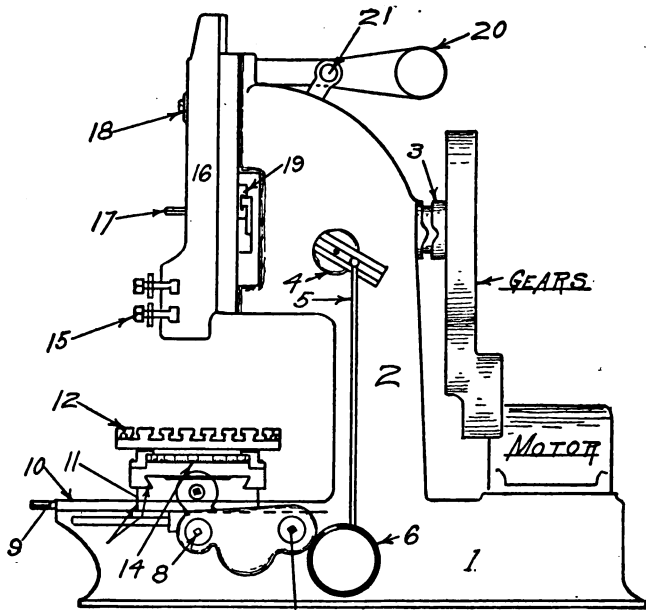

Fig. 162

- | | |
|---|--|
| 1. Base. | 12. Table. |
| 2. Column. | 14. Table graduations. |
| 3. Feed cam. | 15. Tool post clamps and bolts. |
| 4. Feed cam lever. | 16. Ram. |
| 5. Feed rod. | 17. Position adjustment for ram. |
| 6. Feed driving gear case. | 18. Ram connecting rod clamp. |
| 7. Rotary feed shaft. | 19. Crank; this part has an adjustment for setting length of stroke. |
| 8. Cross feed screw. | 20. Ram counterweight. |
| 9. Lengthwise or longitudinal feed screw. | 21. Ram counterweight links. |
| 10. Table base. | |
| 11. Table saddle. | |

The two unmarked arrows indicate location of gibs. These are adjusted to take up wear, or to clamp the table when it is to be held in a fixed position.

forth as indicated by the dotted lines, just strikes the cutting edge of the tool. Next, by means of the cross feed screw, move the table so the knee stands in position indicated by the dotted lines of the tool, and test by using

the scale as previously described. The knee must be adjusted until the contact of the scale with the tool is the same at both ends of the knee; it is then ready to use as a guide in setting the work. Tighten the knee solidly.

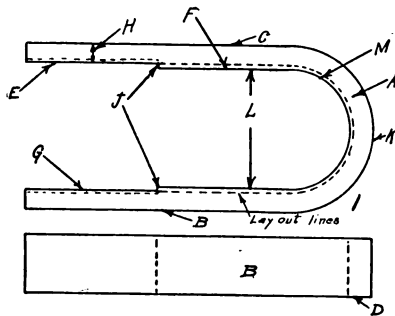

Fig. 163

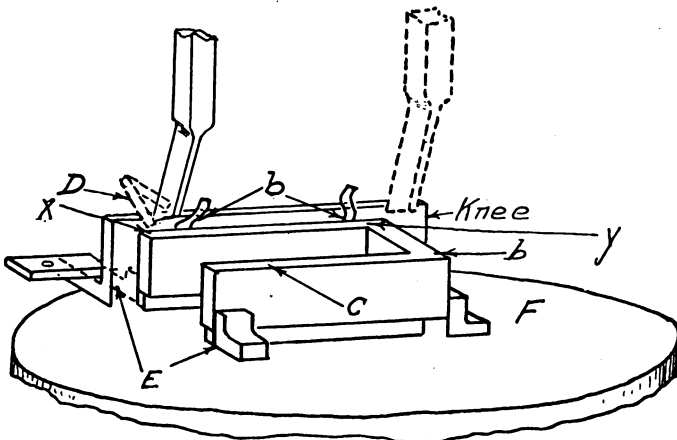

Fig. 164

The piece should be laid out from the drawing as indicated by the marks on the surface, Fig. 163. Place the work on two parallels, having the parallels in such a position that the tool may pass completely over the surfaces

E, *F*, and *G*, without striking them as it cuts. Set the work back against the knee, and clamp it lightly; place a couple of strips of paper, as shown at *b*, and with a lead hammer tap the work back so the pieces of paper cannot be pulled away from between the surface of the knee and the work. Clamp the work solidly with clamps at *b* and *C*, remove the knee, and place a clamp at *x* and *y*. It is necessary, in this class of work, to clamp it so it will not only be held down, but so it cannot move relative to the surface of the table. Stop clamps are placed as at *E* and *F* to prevent this latter movement. Stop clamps are much used, on the slotter and planer.

The cutting tools used on the slotter are shown in Fig. 165. *A* is a surface roughing tool, *B* is a surface finisher, *D* is a right hand cornering tool, *E* is a left hand cornering tool, and *F* is a keyway tool. After the work has been properly set up we are ready to start cutting, and for this we use the roughing surfacer. Run cuts over surfaces *E*, *F*, and *G* leaving about $\frac{1}{8}$ " for the finishing cut. Use the inside caliper for the purpose of measuring the size of the work. The layout will serve as a guide in keeping the cuts in a central position. After taking the roughing cuts, place the finishing tool in position and finish surface *E* so the cut passes exactly along the line of the layout. In running this cut a lubricant may be used, as this produces a more satisfactory finish. It may be wise, if the working limit is very close, to measure the thickness of the strap at *H* with an outside caliper, though as a rule this is not necessary. The surface *G* and surface opposite *F* are now finished in the same manner as described for surface *E* using the inside caliper to determine the finished dimension. The shoulders at *J* are now carefully finished, using a right and left hand cornering tool. The next step is the finishing of the cylindrical surface *M*.

The particular interest in this job at present centers on the "set up" and operation for finishing the cylindrical surface. A tool much used in machine shop practice, when setting up on any machine, is the scribing tool shown at *G*, Fig. 165. To arrange for the proper method of setting up, we first locate the center of the slotter table. Usually there is a hole in the table, and the work-

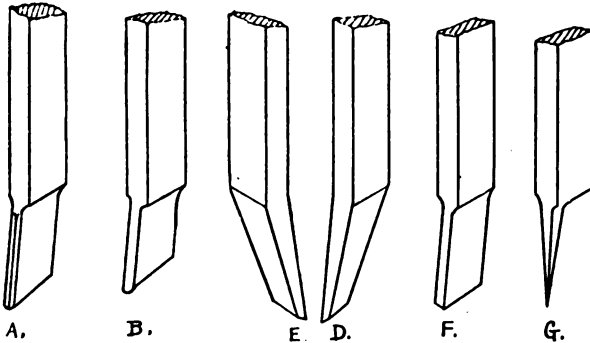

Fig. 165

man makes a target as shown at Fig. 166 which is driven into this hole. The trammel points are used to determine the center of the table in the same manner that a hermaphrodite caliper was used to locate the center of a straight piece in the study of centering. A small center punch mark should be placed to locate the exact center, scribing tool placed in tool post, and the point of the scribing tool set so it is true to this center. The work should be located approximately true by laying it on the table, and with a scale measuring from the point of the tool to the layout as shown in Fig. 163. Clamp the work lightly in place, and bring the scribing tool to the line of the layout by means of the cross feed screw. Do not move the table with the lengthwise feed screw, after it has once been located centrally. All gibs should be set

up closely when radial work is being done. To set the work accurately, move it by means of the cross slide screw, so a point of the layout coincides with the point of the scribing tool. Now by means of the rotary feed, swing the work beneath the scribing tool and see if the

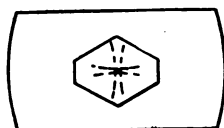

Fig. 166

Center target. Target is of hard wood, cut to size with a jack knife. Any piece of wood picked up about the shop can be used as a target, though hard wood gives best results. Bend down corners of tin center piece so they will form spurs, and drive same into face of target.

The piece is now firmly clamped, stop clamps placed, and the cuts started, using roughing tools first, and following with finishing tools. Two surfaces are finished cylindrically, one at *M* and one at *K*. The finished cylindrical dimensions are determined by the surfaces *L* which may be used as gaging surfaces bringing the tool up so it just touches for starting the finishing cut.

Keyway Cutting. — This work, on the slotter, consists of cutting keyways in hubs of gears, pulleys, etc. In the cutting of a keyway in a hub, the workman must see that it is true relative to the center of the hole. In laying this work out, we use the target again, and carefully locate the center by means of a divider as shown in Fig. 167 at *A*. Locate the center accurately with a prick punch, and by using a scale and scribe, draw a line through the center we have just located, extending it over the face of the hub as shown at *b*, *c*. This line now becomes a basis from which to lay out the keyway. At any points on this line, as *e* and *f* for example, place two center punch marks, and, with the divider set to a radius equal to half the width of the keyway, strike two circular arcs as shown

at these points. Draw lines tangent to these arcs directly across the face of the hub. From the edge of the bore, at *g* lay off the depth of the keyway, and place a center punch mark, showing the limit of this depth.

Mount the work on the table, supported by parallels, so that the cutting tool will pass completely through the hub, to cut the full depth of the keyway. Clamp the work lightly in place. The scribing tool is now used again to set the line *bc* true to line of lengthwise travel of the table. The manner of setting this line is the same as that described in setting up the connecting rod strap to its layout. The method consists of traversing

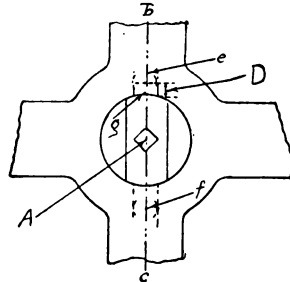

Fig. 167

the table back and forth in the line of the slide movement, and moving the gear slightly in required directions, till the tool follows the line *bc*, throughout its length.

A little thought will make clear the fact that we have laid the keyway out true relative to the center of the bore, and set the job up on the machine, true to the layout. The cutting is started with a roughing tool which is about $\frac{1}{8}$ " narrower than the size of the keyway, and finished with a tool the exact size of the keyway. Measure the depth by means of a steel rule.

The depth of a keyway is always measured as indicated at *D* in this figure.

In setting the stroke on the slotter, have the tool pass through the work on the lower face about $\frac{1}{8}$ ", and rise above it on the upper face about $\frac{1}{2}$ ". In feeding the table to the cut, always make the feeding movement while the tool is entirely out of the work. When cutting keyways

$\frac{5}{16}$ " and under, it is customary to use but one tool, the roughing operation described above being omitted.

The slotter, like the shaper, is a machine tool used for a number of special detail processes about the shop. The principles involved, however, are very well covered by the jobs just described.

QUESTIONS

1. For what class of work is the slotter commonly used?
2. Describe and illustrate the more common slotter tools.
3. Give a brief description of the method of laying out and cutting a keyway on the slotter.
4. Describe the setting of the slotter for taking a circular cut.
5. Describe the setting for finishing two parallel surfaces.

CHAPTER IX

THE GRINDER

THE grinding machine, or grinder, is a comparatively modern machine tool. Originally this was simply a finishing tool used to eliminate filing, or for producing a very fine finish on work. At present, the grinder is essentially a production tool, because it very materially reduces the cost of lathe work. Work done on the lathe need not be highly accurate, when the grinder is to be used in finishing the work, because all the accurate work can be more quickly finished on the grinder. Figure 167 *G* shows a view of a modern grinding machine, and the notes with the illustration explain the functions of the various parts. Study these with care, and, in starting work on the machine, learn the method of operating the various levers and the effect produced by such operation, before starting on a job.

In connection with the grinder, the overhead works, that is the countershaft, with its various pulleys, should be studied with more care than is necessary in connection with the machines previously described, because it is common practice to place cone pulleys in the overhead works of the grinder, which enable the operator to obtain certain speeds. In the particular machine illustrated two speeds are obtained by changing the driving belt on cone pulleys in the overhead works.

A careful study of this machine will show that the grinder is similar to the lathe, in many respects. The work is mounted on centers, the method of driving work is similar, and the arrangement of feeds and speeds is

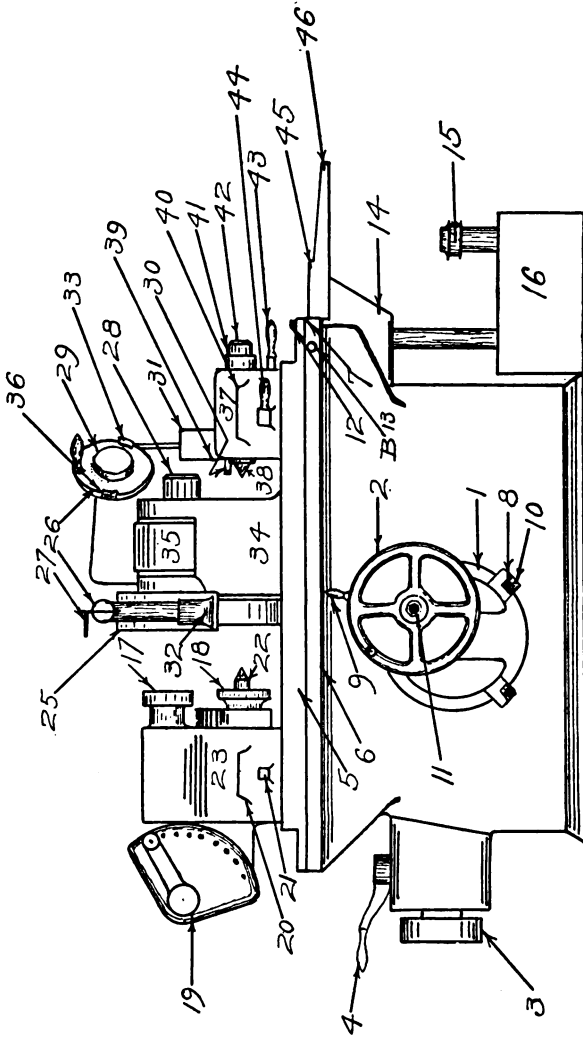

Fig. 167 G

- the use of this mechanism, depending on the position of the driving belt on the cone pulleys located in the overhead works.
20. Splash guard supports; on all grinders guards are used in front of the wheel to prevent the coolant from being thrown about the floor. These guards, on the machine under study, are carried on rods which rest on supports 20 and 40.
21. Headstock clamp bolt.
22. Headstock center.
23. Driving head.
25. Wheel guard.
26. Coolant pipe from tank to wheel.
27. Coolant control valve.
28. Wheel spindle bearing.
29. Cross feed hand wheel; in many designs this wheel is located at the front of the bed near the longitudinal feed handwheel.
30. Automatic cross feed cam plate.
31. Automatic cross feed counterweight.
32. Coolant distributing nozzle.
33. Automatic cross feed latch.
34. Wheel head slide and base.
35. Grinding wheel driving pulley.
36. Micrometer adjustment for automatic cross feed.
37. Footstock main casting.
38. Footstock center.
39. Footstock spindle.
40. Splash guard support.
41. Footstock spindle adjusting nut.
42. Footstock spindle adjusting screw.
43. Footstock spindle shifting lever.
44. Footstock clamping lever.
45. Wheel traverse table.
46. Wheel table guard.
1. Table stroke control wheel.
2. Handwheel for lengthwise movement of table.
3. Table feed driving pulley.
4. Table feed change lever.
5. Table swivel.
6. Table base.
7. Table graduations.
8. Table stroke control dogs.
9. Table reverse lever.
10. Stroke dog adjustment.
11. Automatic feed knob.
12. Table swivel clamp screws; note these at each end of table.
13. Also indicated by *B* — table swivel adjusting screws.
14. Catch basin; catches coolant, and returns it to tank.
15. Pump for circulating coolant.
16. Tank containing coolant.
17. Spindle driving pulley.
18. Face plate.
19. Spindle speed change mechanism. Two separate sets of speeds are obtained by

All grinders are not of the same form as the one shown, but all have the same elements of operation, which should be looked for and studied, when starting on this machine tool.

much the same as the lathe. The cutting tool is quite different; a grinding wheel is used instead of a piece of steel, and this wheel is the first thing we study after becoming acquainted with the parts of the machine.

The wheels used for various kinds of work on the grinder are graded, by the makers of wheels, to meet the requirements of varied demands. All wheel manufacturers do not use the same system of grading, but the system presented below, which is that of the Norton Co., Worcester, Mass., is typical, and may be used as a general guide in specifying wheels. The cutting qualities of a grinding wheel depend on two things, the **grade** which refers to the hardness or softness of the wheel, and the **grit** which refers to the size of grain of the material, of which the wheel is composed. This grading is determined in the same way that the grading of emery is determined as described in an earlier chapter. The size of the abrasive used in grinding wheels varies from 10 to 200. The range of grits commonly put on the market by the Norton Co. is as follows: #10, 12, 14, 16, 20, 24, 30, 36, 46, 50, 60, 70, 80, 90, 100, 120, 150, 180 and 200.

The grade list of the Norton Co. is given below:

E. Soft	Q. Medium hard
F.	R.
G.	S.
H.	T.
I. Medium soft	U. Hard
J.	V.
K.	W.
L.	X.
M. Medium	Y. Very hard
N.	Z.
O.	
P.	

The series of numbers given above indicate the coarseness of the material used in making up the wheel, the lowest number being the coarsest grit of wheel, and the highest number the finest grit; the grade list is self-explanatory; whenever a wheel is mentioned in relation to its cutting capacity, the grade and grit are always given; thus we say that for grinding soft machine steel grade M, grit #36 is a good wheel; by this we mean that a wheel of medium density (see grade table) and #36 grit will give good service on this class of work.

When grinding wheels first came into use, emery was the abrasive used almost exclusively: emery is a natural product; most of the abrasive wheels in use at the present time are made from some artificial, that is, manufactured abrasive; probably the most common ones are alundum and carborundum; these terms are trade names for the abrasives manufactured; the wheel used for most of the work done on grinding machines is a *vitrified* wheel; that is the abrasive material is mixed with a kind of clay which will melt, as it were, at a high heat; the wheel is then molded and trued up, after which it is put in a kiln, subject to a high temperature which fuses the clay, and binds the abrasive in a solid mass. The vitrified wheel is a strong durable article, if it is handled with reasonable care.

When we take up the study of internal grinding we shall have occasion to use the elastic wheel for some grades of work; this wheel is made in small sizes and is very thin, being useful for working in close quarters, since it does not break as readily as the vitrified wheel; this wheel is made by mixing the abrasive material with a kind of varnish, and baking it at a low temperature; the elastic wheel is graded by numbers as follows:

1, 1½, 2, 2½, 3, 4, 5, 6.

The softest wheel is grade #1, and the hardest is grade #6, in the elastic range. Grits in the elastic wheel are not as coarse as in the vitrified wheel; probably an average range of grit for this wheel is 40; for a general line of work, a grade #2½ grit #40 will prove satisfactory. The learner should not gather from the above statements that all internal grinding is done with elastic wheels, for it is not; vitrified wheels are used for grinding internally, more than are elastic wheels.

Before we can intelligently start a job we must have some idea of what kind of a wheel we ought to use, because our first job in starting work is the placing of the wheel on the wheel spindle; the following notes are suggestive:

Surface speed of wheel 5000 ft. per minute.

For soft machinery steel use grade M, grit #36 vitrified.

For same kind of stock, but long slender work, use grade L, grit #36 vitrified.

For cast iron, when a high finish is wanted use grade #4, grit #36 elastic.

For chilled cast iron use grade #4, grit #36 elastic.

For brass and copper use grade #4, grit #36 elastic.

For tool steel and case hardened machine steel use grade K, grit #36 vitrified.

The above list is not given as a suggestion that no other wheels shall be used for the materials mentioned, but rather as a guide to the learner in selecting wheels; in each case mentioned, the particular wheel has been used on the class of work mentioned, and has given good results.

Work Speed.—The wheel speed mentioned above, that is 5000 feet per minute, is a good average rate of travel for the wheel; in modern grinding practice this item varies from 5000 to 7000 feet per minute with good results; the

work speed varies to a more marked extent and the following list is presented as a guide for the learner in selecting the speed at which the surface of the work should run:

Soft machinery steel 35 feet per minute.

Hard machinery steel 35 feet per minute on the roughing cut, and 60 feet per minute on the finishing cut.

Case hardened machinery steel, and tool steel 35 feet per minute.

Cast iron 55 feet per minute.

Bronze and brass 75 feet per minute.

In small plants the worker often finds himself so placed that he may not keep several wheels on hand, as the most rapid production is not demanded, but rather a reasonable production, with a small outlay for wheels; if an operator may have but one wheel a grade M grit #36 will be found generally serviceable; with the smaller wheels one is not limited so closely in the matter of the number of wheels to be kept in stock, even in small plants, because they are not very expensive; so it is wise to keep enough different kinds of wheels in stock for all the different materials one may be called to handle as internal grinding work, to assure the use of the proper wheel for each particular material.

Grinding is broadly divided into two classes, external and internal; external grinding is that class of work in which the wheel acts on an outside surface; internal grinding is the class of work in which the wheel acts on an inside surface; external work is again divided into cylindrical and surface work; in doing cylindrical work the wheel is operated on a piece of work revolving on centers; in doing surface work the wheel acts on a flat surface; cylindrical grinding is further subdivided into *traverse grinding*, *fixed wheel grinding*, *step-in grinding* and *straight-in grinding*. By far the most common form of

grinding is traverse grinding; in this operation the wheel is moved past the work by means of the automatic feed, or by hand feed, as the requirements of the job may demand, and the wheel is fed into the work, either by hand or automatically, a slight amount each time it passes over the work, till the required diameter of the work has been obtained.

In the fixed wheel method instead of feeding the wheel in on the work a small amount each time it passes over, the wheel slide is "set" against a stop if there is one on the machine, and the wheel run back and forth over the work from two to half a dozen times; when the piece is removed the wheel is not adjusted; no resetting of the wheel is done till it has become so small due to wear that another setting is necessary in order to produce the required diameter of work; in grinding by the fixed wheel method, the gibs on the wheel slide should be set up very closely so the wheel may not be easily moved, or sprung, as the machinist expresses this action, when the grinding operation is going on; it is not wise to attempt the use of the fixed wheel method of grinding on long slender shafts, or with a lightly constructed machine, as satisfactory results cannot be obtained; this method demands a solidly built machine, and should be applied on short stiff work; it is wise not to leave a large amount of stock to be ground when using the fixed wheel method of grinding.

Step-in grinding consists of grinding the work by a series of steps, each step about $\frac{1}{4}$ " narrower than the width of the wheel, so that the cut is overlapped in each case; the piece is not finished to size by stepping in; the work is usually brought to within about 0.002" of size by this method, and then a traverse cut run over to give the finished diameter over the whole length of the piece; generally speaking, step-in grinding may be used on pieces

of work that are rather short and heavy, on a rigid machine, the same as described for fixed wheel work, but where considerable stock is to be removed by the grinding process.

The step-in method is also known as form grinding, and the term is used to designate either plain cylindrical work, or work of irregular shape; the work should be comparatively stiff for this operation and a rigid machine is necessary; the most common application of form grinding at present is the grinding of automobile parts, particularly crankshafts; these are cylindrical surfaces, but they are of such a design that it is not practical to

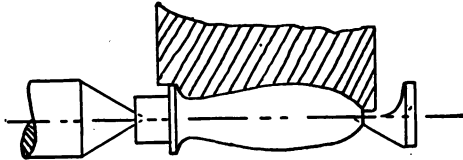

Fig. 168

use either the traverse or step-in method; Fig. 168 illustrates the grinding of a handle bar for a lathe by the form method; a special truing device must be built for keeping the wheel in condition for operation when doing this kind of work, and the difference between the largest and smallest diameter of the work must not be too great, otherwise it will be impossible to secure proper cutting action when grinding; as a guide it may be stated that the difference between the largest and smallest diameter required on a form wheel should not be over $1\frac{1}{2}$ " or 2"; as a general rule work and wheel speeds for form grinding may be about the same as for other classes of grinding; the same statement holds true for fixed wheel and step-in work.

Truing the Grinding Wheel. — In the study of the text on grinding the learner has seen the truing of the wheel

mentioned; a new wheel mounted on the spindle of the machine will not run true, that is all parts are not equally distant from the center of rotation; for this reason, when the wheel is started in operation on a piece of work, one part of the circumference will strike the work, while other parts will not. The next step after mounting the wheel and oiling the machine is to true the wheel. This work is done with a tool called a diamond; this is a very hard substance ranging in color from green to dark

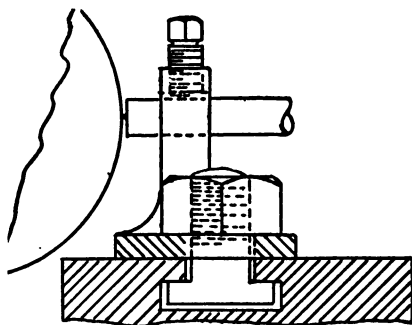

Fig. 169

brown. The diamond is set in a steel holder as shown in Fig. 169; the trade name for this material is "bortz"; it is also spoken of as black diamond; the figure just mentioned shows the diamond properly mounted on the machine preparatory to truing the wheel; start the wheel, bring it up by means of the cross feed so it just touches the diamond, and by means of the lengthwise feed handle slowly pass the diamond over the wheel; after the wheel has been cut down so it runs true, put the slow feed in gear and allow the diamond to pass over the wheel two or three times by means of this feed. This is the proper method of truing when you are to grind cylindrical or taper work by means of the traverse method.

One is often required to true a small wheel on a polishing stand, or round the corner of the wheel as to be described later in truing for set wheel work, and then the diamond may be held in the hand, supported on a rest as shown in Fig. 170. The diamond must be held firmly, and pressed lightly against the wheel, moving it slowly back and forth over the face of the wheel, till the desired condition of wheel face has been obtained.

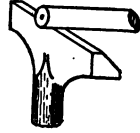

Fig. 170

In truing the wheel for fixed-wheel work or irregular form grinding we must change, somewhat, the process just described; for fixed-wheel practice the side of the wheel which advances to the cut as we feed the work past the wheel should have the edge slightly rounded as shown in Fig. 170 A; furthermore this side of the wheel is tapered about $\frac{1}{32}$ " for about $\frac{1}{2}$ " as illustrated in the same figure; the rounding of the edge is done by hand as just described, while the "tapering" is done setting the machine as though grinding a taper, and mounting the diamond in the holder as previously described.

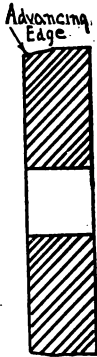

Fig. 170A

For form grinding cylindrical work, or conical work, no other methods than those described are necessary; for irregular work, however, such as previously illustrated, a special fixture is necessary, which will cause the diamond to move in a path that will shape the face of the wheel to the desired form; this fixture is mounted on the table of the machine, the machine table is locked fast, and the diamond commonly moved over the face of the wheel by means of a lever, operating the slide which carries the diamond.

The Grinder Steady Rest. — All work on the grinder does not demand the use of a steady rest; short work of large diameter can usually be ground without it, but if the work is very heavy it is a good plan to put on a rest in order to relieve the centers of weight; if you study the grinder you will notice that the footstock center is

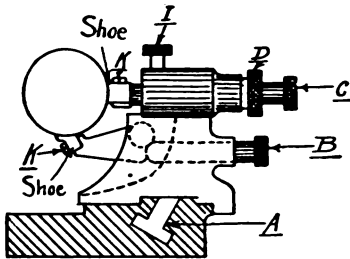

Fig. 171

- A. Rest clamping bolt.
- B. Lower shoe adjustment.
- C. Upper shoe adjustment.
- D. Upper shoe spring adjustment
- I. Upper shoe clamp.
- K. Shoe clamping bolt.

held against the work by means of a spring instead of being adjusted entirely by a screw as was the case with the lathe; this feature is introduced in the footstock design of the grinder, because work expands more in grinding, due to heat, than it does in turning, and this spring permits the footstock spindle to adjust itself automatically to the variations of the

work due to expansion. If a very heavy piece is carried between the centers without a steady rest, it is apt to force the footstock center out of place, and thus the work is dropped from the machine.

Each builder of grinding machines has a design of steady rest which adapts itself to the machine which he puts on the market; so far as operation is concerned the various designs of rests are not essentially different; all are clamped to the machine table, and the parts which bear against the work are adjusted by means of screws at the front and within easy reach of the operator. The steady rest is used for the purpose of supporting the work, so it does not spring away from the wheel and thus produce work that is not the same diameter throughout its

length; the steady rest also prevents chattering; Fig. 171 is a steady rest which is used by one of the large manufacturers of grinding machines; the rest is clamped to the work table by means of the screw bolt *A*, and the lower shoe is adjusted by the screw *B*, The horizontal shoe is adjusted by the screw *C*; notice that there is a spring adjustment *D*, which acts to push this shoe against the work when setting up the machine. The clamping screw *I* is used to clamp the plunger, which carries the shoe solidly in place after adjustments have been made.

Study the drawing of the steady rest carefully, and familiarize yourself with the names of the various parts. For general shop practice, where a great number of pieces of work of the same kind are not to be produced, steady rest shoes are made of wood, such as hickory or maple, and prove satisfactory; ash and beech are good woods for this purpose. In setting up the machine, the workman must decide how many steady rests he will use; as a guide it is suggested that a rest be placed every six inches along the length of the work; this spacing may be departed from as the learner gains experience, and becomes capable of judging, by the way in which the machine operates, just how many rests should be used.

Preparation of Work for the Grinder. — The learner will recall, that in connection with the lathe work the turning was very accurately done; the job we had on the lathe, however, was not to be ground after turning; if it had been ground we would not have finished it so accurately. We would have faced the ends up in the same way we did originally, but instead of turning to accurate size, we would have left about $\frac{1}{32}$ " for grinding; that is, we would have left the work $\frac{1}{32}$ " too large in diameter; this would have been removed in grinding; when a piece is to be ground after turning, it may be turned much

more roughly; that is a coarser feed may be used and the lathe need not be trued up with the same accuracy described in an earlier chapter; the accurate work on the job is completed with the grinder.

As an example of work on the grinder we will take a shouldered shaft. Before putting the work on centers, be sure that the holes carrying centers in both headstock and footstock are clean; remove the centers, wipe them off and clean the holes as described in connection with the lathe; we will not find it necessary to test the headstock spindle of the grinder for truth when running, because in modern grinding practice both centers are "dead"; that is, neither one revolves; now look at the grinder table at point 7, Fig. 167 *G*, where you will find a series of graduations for degrees and inches per foot of taper similar to those described on the taper attachment, in connection with the lathe; these graduations are used for the same purpose on the grinder as on the taper attachment, namely to set the table when grinding tapers. Be sure the 0 index line on the swinging table of the grinder corresponds with the 0 line of the graduations on the base before starting to do any grinding; if you are not particular about this point the grinder will not produce a straight piece of work.

The next step is to put the steady rests in position, being sure that there is no dirt on the surface of the table, nor on the surface of the steady rest which bears on the table. Slack the shoes well back in the rests so you have ample room for placing the work, run the wheel well back out of the way, put some oil on both headstock and footstock centers, see that a grinder dog is on the work and place it on the centers. We must next set up the steady rest shoes; start the work revolving, and bring the horizontal shoe against the work, then the bottom shoe, setting them up closely but not

too tightly. The travel of the table must now be set by means of the dogs; see Fig. 167 *G*, #8. Start the wheel revolving, and run the table *by hand* to the position where we wish the reversing movement to take place; now set the dog so it strikes the shipper lug of the reversing mechanism, then run the table to the other point of the stroke. Now leaving the wheel well back out of the way, throw in the traverse feed of the table, and see if the reversing mechanism trips exactly at the desired point; it probably will not do so, and we must correct the adjustment either by moving the tripping dogs slightly or adjusting the set screws which will be found on them. In grinding practice it is usual to have the table move forward about two thirds of the width of the wheel for each revolution of the work: thus if you are using a wheel $1\frac{1}{2}$ " wide on the face you would wish the work to advance about one inch for each revolution. A wheel about $1\frac{1}{2}$ " wide is a very satisfactory general purpose wheel, so we may assume that such a wheel is being used. The feed adjustments for the grinder table are made by means of a gear box, very similar to that used on the lathe, while the variation in the rate of revolution of the work is made by the shifting of gearing in the headstock, through the medium of levers. Changes in the wheel speed are obtained by shifting an overhead belt on a set of cone pulleys.

We know that a piece of work expands more when being ground than when being turned. To prevent the heating which causes such expansion, cooling material is constantly passed over the work, while it is being operated on. At 32, Fig. 167 *G*, is shown the nozzle and deflector attached to the delivery line of the pump that supplies the cooling material or coolant. The nozzle and deflector should be adjusted so as to throw plenty of cooling material on the point where the wheel and work come

in contact; do not adjust the deflector so that most of the cooling material runs over the work, and away from the cutting point. Bring the wheel up till it is within a small distance of the work, having first thrown in the automatic table feed, and allowing the work to traverse back and forth as the wheel is brought up; by this means the workman may watch the action of the reversing mechanism and be sure the table does not travel too far in either direction; if it does adjustments must be made before the wheel is in close enough to the work to strike any shoulders. When the wheel is within about $\frac{1}{16}$ " of the work, throw in the automatic cross feed which advances the wheel slightly each time the wheel starts a traverse movement. Bring the wheel up to the work till it begins to cut, and then let the machine run. After it has passed over the work, two or three times, throw out the cross feed, run the wheel away from the work, and shut off the supply of cooling liquid. The work should be measured now, both to see how near the finished size is being approached, and if the work is straight.

If the machine is not grinding straight; slack off the table clamp bolts and move the table slightly in the proper direction, by means of the screws *B*, Fig. 167 *G*. Be sure to tighten the table clamp bolts again before starting the machine. When starting the cut again, bring the wheel carefully up to the work, throw in the feed, and run light cuts until the wheel is cutting the full length of the work. Measure or gage the work frequently, till it is brought to the proper diameter. As the grinding proceeds, be sure to adjust the steady rest shoes so they are at all times in close contact with the work.

Cooling Materials or Coolants. — A very good cooling material for use on the grinder, when a general line of work is being done, is made by mixing about five gallons

of water with one half gallon of soft soap, and putting into this mixture enough common washing soda so that it will turn white when a piece of iron is wet with the mixture and allowed to dry. The supply dealers in the various cities can supply a preparation known as "aqua-dag" which when mixed with water produces a very excellent cooling medium for use when grinding.

When preparing work for the grinder, the workman should slightly "neck" the work under any shoulders. This permits the wheel to produce a perfectly cylindrical surface over the full length of the surface ground, and allows the various shaft shoulders to fit closely against the mating parts when the piece is assembled.

QUESTIONS

1. In what particular characteristics is the grinder similar to the lathe?
2. Explain the meaning of grade and grit as applied to grinding wheels.
3. Describe the system of grading elastic wheels.
4. Describe in full the various classes of external grinding.
5. Explain the method of truing the grinding wheel on the grinder.
6. For what purpose is the steady rest used on the grinder? How is it applied?
7. How may a grinder be adjusted if it does not grind straight?

CHAPTER X

GRINDING — *Continued*

Internal Grinding. — Internal grinding is similar, in so far as operations of a general nature are concerned, to chuck and face plate work in the lathe. The work, itself, is carried in the chuck, and trued up in a manner similar to that followed when truing work in the lathe. A great deal of internal grinding requires not only finishing the hole in the work, but finishing the face of the work, so it runs true with the hole. We will study a job requiring the grinding of the hole and two faces, all true to each other. The first step is to mount the work in the chuck. If we use a chuck on which all the jaws move separately, we true the work in the same manner as described for mounting chuck work in the lathe. We must be more accurate in our work, however, as we have but a few thousandths of stock to remove. After the work has been set approximately true with chalk, we mount an indicator as shown in Fig. 173, and set the work so it does not run out more than 0.002". We must also see that the work is equally true on the face; this truing on the face is done by running the machine, and marking the face of the work with chalk. The work is driven back in the chuck slightly at the marked section, till a mark is obtained all around the face of the piece, as indicated by small arrow, Fig. 173. The test indicator is used for the final truing within the desired limits.

The operation of truing must be repeated once or twice, in order that truing the face may not throw the bore out of truth, and vice-versa. For a great deal of grinder work, the universal chuck is used instead of the inde-

pendent chuck; this chuck is so designed that all the jaws operate at one time, by the movement of any one of them. The universal chuck is quite accurate if the tool is properly cared for and properly used. In placing a job in a universal chuck, do not assume that the tightening of one jaw is all that is necessary; all the jaws must be tightened up, one after another, till we have removed all the backlash in the jaw screws; usually this means that the jaws should be tightened up twice, one after the

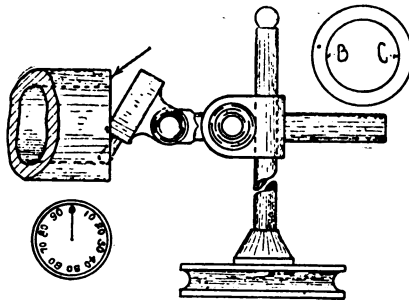

Fig. 173

other. In mounting the chuck on the grinder it is usually necessary to shift the driving belt so that the headstock spindle of the grinder is revolved by the driving belt; this should be attended to, then the front driving pulley removed, headstock center driven out, spindle hole stuffed with some cotton waste, and the chuck screwed in place.

The machine tool on which we are supposed to be working is known as a universal grinder, because it may be used for external and internal, as well as straight and taper grinding. Where internal grinding is to be done on a great deal of work, special internal grinding machines are used. The universal grinding machine is used very extensively for internal grinding, though, and the production rate is very satisfactory, if the tool is properly

handled. The internal grinding attachment is bolted to the wheel head slide #34, Fig. 167 *G*, the wheel for external grinding being removed, and the internal wheel spindle mounted in its place. As the internal grinding wheel must run a great many more revolutions per minute than the external wheel, the internal wheel spindle is not driven by the driving pulley 35, Fig. 167 *G*, but usually through a countershaft, mounted on the slide. A belt runs from a pulley, driven by the main driving pulley 35, to the countershaft mentioned, and this, in turn, is belted to the internal grinding wheel spindle. By this arrangement the speed of the small spindle, carrying the wheel for internal grinding, is very greatly increased. The various bearings of the internal grinding attachment must be carefully oiled, before it is used.

The wheel should be selected, based on the notes given in the preceding chapter. It is assumed that we are grinding hard steel, and a vitrified wheel, grain 46, grade *K*, may be used.

This wheel should be about $\frac{1}{4}$ " smaller in diameter than the hole we wish to grind. The surface speed of the wheel should be about 4500 feet per minute, and that of the work about 100 feet per minute. On certain classes of work, an operator does not use water for internal grinding. If one has a very large piece of work, and only a small amount to be ground from the hole, the heat generated will not affect the work to any great extent. On small work a cooling medium is always an advantage; it can be delivered to the wheel by means of a flexible metallic hose, connected to the coolant supply.

For internal grinding on the universal machine, the automatic feed is not commonly used; the feeding is done by hand, both of the wheel to the cut, and of the lengthwise movement of the table. The "set up" having been made, the headstock should be examined to see if it

swivels on its base. If it does, be sure that the index lines coincide, showing that the head is set so the spindle center line is true with the lengthwise travel of the table. True the grinding wheel with a diamond, bring it carefully into position, and start the cut. Run a few passes of the wheel over the work, to clean the hole, and remove the scale. As soon as the wheel is cutting over the whole surface of the work, test it for taper by using the inside caliper very carefully. If the work is straight, proceed to grind the hole to size, fitting it to the plug gage. Put a little oil on the gage when you start to test the hole with it, as this will prevent the gage sticking in the work. This fitting will require considerable patience, and much care on the part of the learner, but the training which one gets from doing this class of work is worth all the effort put forth.

The hole being ground true, we are ready to start work on the faces of the piece. These faces must be accurately true with the bore, which has just been ground. The external grinding wheel is used for this work, so the entire internal grinding fixture is removed, and the external wheel mounted on its spindle. Remove the chuck from the spindle nose, clean out the hole in the headstock spindle, and otherwise fit the machine up as you would for external grinding. Do not put the headstock center in place, nor connect the belt for dead center grinding, as the headstock spindle must revolve, in the work we are about to do.

In Fig. 174 is shown a taper shank, expansion mandrel, which is used for such work as we are about to study. The taper shank fits the seat in the headstock spindle, and the body is the same size as the hole in the piece on which we are working. Notice that this body is split by four slots, indicated at *B*, and the movement of the screw *A* expands the body or permits it to contract.

The work is placed on the mandrel, and screw *A* tightened, so as to hold the work firmly in place, the mandrel having first been placed in the headstock of the machine. Swing the wheel saddle slightly so the corner of the wheel, as indicated at *C*, will be presented to the work. True this corner off about $\frac{1}{8}$ " with the diamond. Bring the wheel into position, turn on the cooling fluid and proceed to face up the work in the same manner that work was faced up in the lathe; the work is set on the mandrel in such a way that the face extends over the end of the mandrel about $\frac{1}{8}$ "; this will permit running

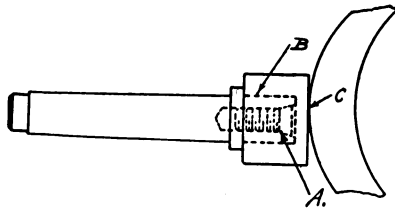

Fig. 174

the wheel over the entire face of the work and giving a true and well finished surface. After the first face of the piece is finished, remove it from the mandrel, and mount it with the unfinished face outward; now proceed to duplicate the operations just described till this surface is true, and the roll has been ground to the required thickness. The finishing of the diameter is an external grinding job, and this work has been described previously.

Taper Grinding. — The adjustment of the machine for taper grinding is very much like the adjustment of the taper attachment for taper turning on the lathe. Looking at 7, Fig. 167 *G*, we see a set of graduations both in inches per foot and in degrees; we set the machine up in the same manner as we do for a straight external grinding job. Be sure that the index lines on

the headstock are set true, then slack off the table binding screws 12 and adjust the table by means of the screws *B* to the desired taper per foot. The fitting of a taper on the grinder is similar to fitting on the lathe; the same gages are used, and the same details must be observed in doing the job; in marking the surface of the work for testing the fit when grinding, use either red lead or prussian blue. Work very carefully until you are sure the taper is correct, as a very small amount of stock removed may spoil the work.

Testing the Grinder. — The testing of the grinder has not been discussed thus far; the reason for what might appear to be an omission is the fact that the graduating marks on the grinder are quite accurate and if the parts of the machine, that is, the headstock swivel and the

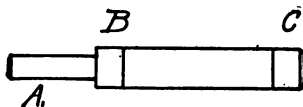

Fig. 175

table, are carefully set to the index lines, there is not the same necessity for testing that the workman meets in operating the lathe. Occasions arise, however, on which the grinder must be tested, and it is a good exercise for the learner. Figure 175 shows a test bar to be used for this purpose; it may be made of soft machinery steel, and should be about $1\frac{1}{2}$ " or 2" diameter in the rough, and from 18" to 36" long, depending on the size of the machine to be tested; the longer the bar, the more accurate the test. Turn one end of this bar down as shown at *A* for a length of about 3", so it is about $\frac{3}{4}$ " smaller than the rough diameter of the bar. The bar should, of course, be centered and carefully faced up before turning.

Mount the bar in the grinder, with the turned portion at the footstock end, and true up about 2" of length, as shown at *B*. Now turn the piece end for end, in the

grinder, and grind about 2" as at *C*, Fig. 175, the same diameter as section *B*. The foregoing operations have simply prepared the test piece. Now take a light cut over end *C*, and, without moving the cross slide of the grinder, lift the test piece from the centers and move the wheel towards the headstock to a point where it will clear section *B*. Now run the cut over section *B*, and caliper both *B* and *C* with a micrometer. If the machine is grinding straight, the two ground sections will be the same diameter; if they are not the table should be adjusted, and the test repeated.

To test the machine when grinding on internal work, let us assume that in grinding the wheel is cutting on the portion of the hole nearest us as at *B*, Fig. 173. True the hole up so the wheel is cutting over the entire surface, for the full length of the hole. Now move the wheel so it cuts at point *C* of the hole instead of point *B*; let the wheel just touch the work so you can see the sparks when grinding dry. Slowly advance the wheel into the hole by hand feed; if the cut increases as the wheel is advanced, it is clear that the machine is grinding large at the front end of the hole; if the cut disappears, you may know that the machine grinds large at the back end of the hole; adjustment is best made by moving the headstock swivel rather than the table, if such a movement is possible.

Chatter. — When grinding, chatter is commonly caused by an incorrect work or wheel speed, or because the work is not properly supported, by means of steady rests. It shows itself in small marks on the work, or a series of wide irregular spots. During the first cuts on a piece, the operator should stop the machine often, and look for signs of chatter. If it shows, he must take steps to prevent it, by adjusting either the steady rests, the work speed, the wheel speed, or changing the wheel.

The feature of constantly watching the work for inaccuracies when operating a machine tool is a very important one. In the matter of testing a grinder, for straight work, it is but rarely that the skilled operator uses the test bar described above. The work is placed on the centers, and the roughing cuts started; as soon as the wheel is carrying a cut over the whole piece, the operator throws out the cross feed, and allows the wheel to make a pass without feeding in the wheel; then he stops the work, calipers and makes any required adjustments; before all the stock is removed on the piece, the machine has been adjusted so it will grind straight.

Whenever working on any piece of stock that is supported on centers, be sure that there are well formed center holes in the piece, and that both holes and centers are perfectly clean. The young worker should write to The Norton Co. at Worcester, Mass., and The Carborundum Co. at Niagara Falls, N. Y., for catalogs of grinding wheels; these booklets contain information of importance when one has occasion to order wheels from dealers.

QUESTIONS

1. Explain the term, "internal grinding."
2. Describe the method of truing a piece of work in the grinder, preparatory to doing a job of internal grinding.
3. Give a brief description of the method of testing the machine for straight grinding, when doing internal work.
4. Describe the method of finishing a "face" true with the bore of a piece which has been internally ground.
5. Explain the method of adjusting the machine for taper grinding.
6. Describe an accurate method of testing the grinder for straight grinding.
7. How can chatter be avoided in grinding?

CHAPTER XI

THE MILLING MACHINE OR MILLER

✓ ONE of the most useful tools in the modern machine shop is the milling machine. It is a tool available for a great many different jobs, it is convenient in operation and interesting in application. The machine is shown in Fig. 176, and the learner should study the figure carefully, in order that the function of the various elements may be understood. Before starting a job on the machine the learner should oil all parts, handle all the levers, and be sure that the effect of each movement made is understood.

The tools used for cutting purposes on the miller are known as mills, and the ones most commonly used are shown in Fig. 177. At *A* is shown an end mill, at *B* a side mill, at *C* a slab mill, and at *D* a gear cutter. The commonly used auxiliary attachments on the miller are the vise, the dividing head centers and the vertical milling attachment. The vise is commonly used for jobs requiring surface operations, such as slabbing or end milling. The centers are used for milling bolt heads, nuts, cutting gears, etc. The vertical milling attachment is used for certain jobs which cannot be operated on conveniently when the mill is held directly in the machine spindle.

As a slabbing, end milling, and side milling operation, we may study the piece of work shown in Fig. 179, which is part of a machine used in the manufacture of wood screws. The first step is to finish the surface *A*. This is done by setting the job in the vise, so that surface *A*

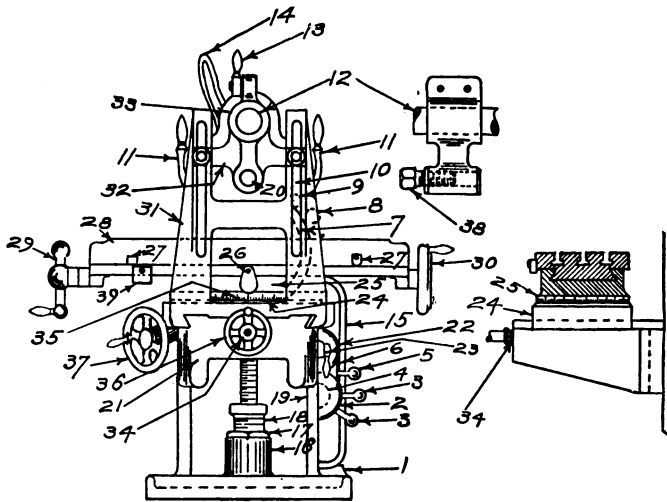

Fig. 176

This figure shows a milling machine as it would appear if you were standing directly before the knee of the machine.

- | | |
|--|--|
| 1. Auxiliary shelf for carrying index centers when not in use. | 25. Table base; note that this swivels. |
| 2. Feed gear box. | 26. Lengthwise feed, operating lever. |
| 3. Feed gear tumbler levers. | 27. Feed trip dogs. |
| 4. Circulating pump for forcing cutting lubricant to cutter. | 28. Table. |
| 5. Feed gearing index lever. | 29. Lengthwise feed handwheel. |
| 6. Feed index plate. | 30. Lengthwise quick return handwheel. |
| 7. Main driving pulley. | 31. Arm brace yoke. |
| 8. Speed change gear tumbler lever. | 32. Arm brace; these parts are to support the arm when running heavy cuts. |
| 9. Speed change gear index lever. | 33. Outboard center support. |
| 10. Speed index plate. | 34. Cross-feed micrometer dial; a similar dial is mounted on the vertical feed handwheel. These dials enable the workman to adjust the knee to limits of .001". A similar dial is also mounted on the lengthwise feed screw. |
| 11. Starting levers; one at front and one at back of machine for convenience in operation. | 35. Graduations on swivel table base. |
| 12. Overhanging arm. | 36. Cross feed handwheel. |
| 13. Overhanging arm clamp. | 37. Vertical feed handwheel. |
| 14. Lubricant conducting pipe, upper section. | 38. Center adjustment. |
| 15. Lubricant conducting pipe, lower section. | 39. Table stop; on some machines two stops are used, but more often one stop is placed on right or left end of table as requirements of job demand. |
| 16. Elevating nut seat. | |
| 17. Elevating screw nut. | |
| 18. Telescoping elevating screw. | |
| 19. Column face. | |
| 20. Main spindle of machine. | |
| 21. Knee; main casting. | |
| 22. Feed transmission gears. | |
| 23. Operating lever for vertical feed. | |
| 24. Cross slide; note gibs for adjustment of this member. | |

is approximately level. This surface may be tested by using the surface gage. A slab mill cut is run over the surface, cleaning it up, but at the same time the workman must be careful that too much stock is not removed. When setting the vise on the table of the machine, be careful not to allow any dirt to remain between the

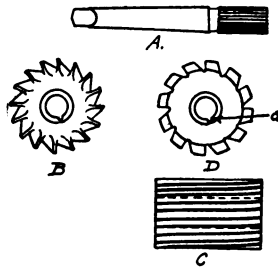

Fig. 177

A is an end mill; made in both right- and left-hand form. To determine the hand of a mill, hold it by the shank, or as it would be mounted on an arbor in the machine spindle; if it must turn to the left to cut, it is a left-hand cutter; if it must turn to the right, it is a right-hand cutter.

B is a side milling cutter; made in various thicknesses and diameters.

C is a slab mill for surface milling; teeth are often nicked for heavy work, so as to break the chips.

D is a gear cutter; note keyway at *a*; keyways are much used in cutters to be operated on heavy work.

Inserted tooth milling cutters are made for side and face milling, similar to *B*, only the body of the cutter is of cast iron or steel. In this design of cutter, teeth are of tool steel and set into the cast iron or soft steel cutter head. Inserted tooth cutters are commonly 6" or more in diameter.

lower face of the shoe and the machine table. File off any rough spots or burrs. The mill is mounted on an arbor; be sure there is no dirt on the taper shank of the arbor, nor in the spindle hole. Bushings must be placed on the arbor as at Fig. 179 indicated by the letter *B*, to bring the cutter approximately in the center of the length of the arbor. Next place some bushings between the cutter and nut on the end of the arbor, and screw the

nut up tightly by hand. Now place the arbor in the spindle of the milling machine, and move the outboard center support into position to support the outer end of the arbor. Tighten binding bolts holding the outboard arm. See that all gibs on the machine are properly adjusted, so the table moves freely, without any shake. The work is adjusted to the cut by means of the elevating and cross feed handwheels. For slabbing cuts on the miller.

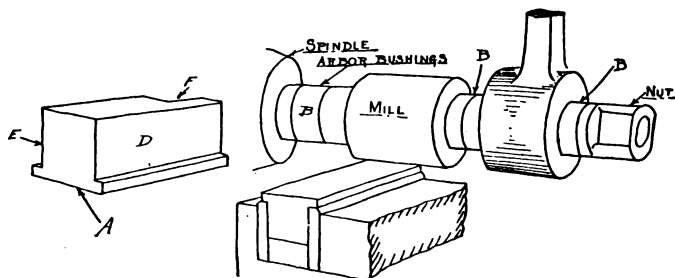

Fig. 179

a lubricant is commonly used, whenever cuts are being taken in steel or wrought iron.

After the surface *A* has been slabbed off, the two surfaces *D* and *E* should be finished. The work is set up for this operation as in Fig. 180; notice the parallels placed beneath the work, and the paper fest strips. Be sure the work is driven down solidly on the parallels, so these strips cannot be pulled out. These test strips should be placed at each end of the work. Use a lead hammer in driving the work in place, and do not drive hard, in setting the work down; strike rather light blows.

There are two ways in which we may mill the surfaces *D* and *E*, set up as illustrated. One is to use a single side mill, and the other is to use two mills, mounted the correct distance apart on the arbor to give the desired distance between *D* and *E*. This class of "set-up" is

known as "straddle milling." Regardless of the method used, we must be careful to keep the central portion of the block equally distant from the surfaces *B* and *C*, so that when we finish surfaces *B* and *C* the dimensions *I* and *J* shall be equal. As a study, we will plan to finish

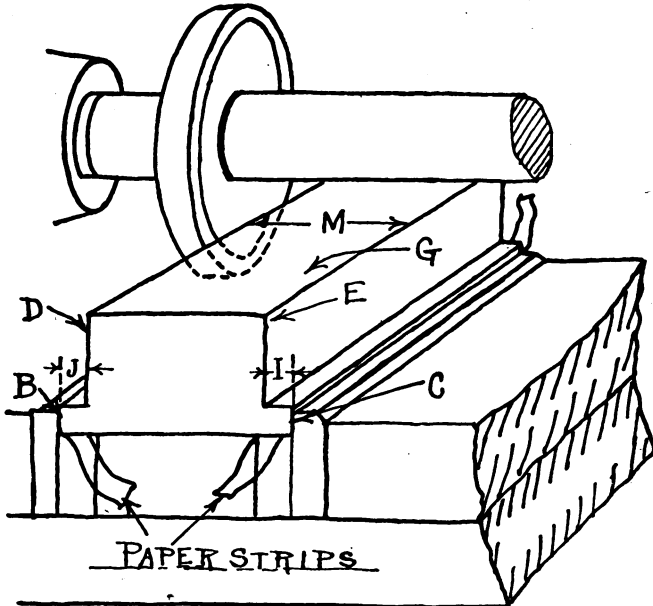

Fig. 180

surfaces *D* and *E* separately, each with a separate cut; this is not the most rapid way of doing the job, since it is evident that the straddle mill method would enable us to finish the work in less time. The single cutter method brings out the operation of the machine better, however, hence the reason for studying this method.

The mill should be placed on the arbor as in Fig. 180 and a cut run on the surface as at *D* for about $\frac{1}{2}$ ". Back the cutter off, and, with a straight edge laid on the section

of cut taken, measure by means of a steel rule the dimension J . With a caliper, measure the dimension M . Two cuts may be run over this surface, and when the finishing cut is made the distance J should be about $\frac{1}{8}$ " larger than the dimension called for on the drawing, and the dimension M about $\frac{1}{8}$ " larger than finished size.

After making the finishing cut on surface D , the table may be moved by means of the cross feed screw so surface E may be finished. At 34, Fig. 176, is located a dial which reads in thousandths of an inch; by measuring the thickness of the cutter, and adding this to the dimension M , the approximate dimension for roughing out surface E may be set with this dial. This should not be depended upon for the finished size, however,

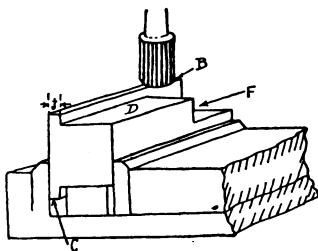

Fig. 181

because any inaccuracy in either cutter or arbor will cause error. The final dimension M should be determined by using the caliper, running the cut on about $\frac{1}{2}$ ", backing off, measuring, and re-setting till the proper size is obtained.

When running the cuts on surfaces D and E do not attempt to finish the flanges at C to size. This work can be more accurately and quickly done by using the vertical milling attachment, and an end mill. The surface G is left rough on this job, so we may take up the finishing of flanges B and C , as well as clearance space F , Fig. 179. The work is placed in the vise as shown at Fig. 181, and the vertical attachment mounted on the arm. In using this attachment, be sure that the table graduations are set true to the index mark. Drive the mill firmly into the spindle, see that the attachment is properly oiled, and run an end cut over surface B , measuring for dimen-

sion with a depth gage. When surface *B* has been properly finished in relation to surface *D*, the thickness of the flange *J* may be finished, at the same setting of the work. Have the end mill sharp, and true for this work, and finish with a cut about $\frac{1}{32}$ " in depth.

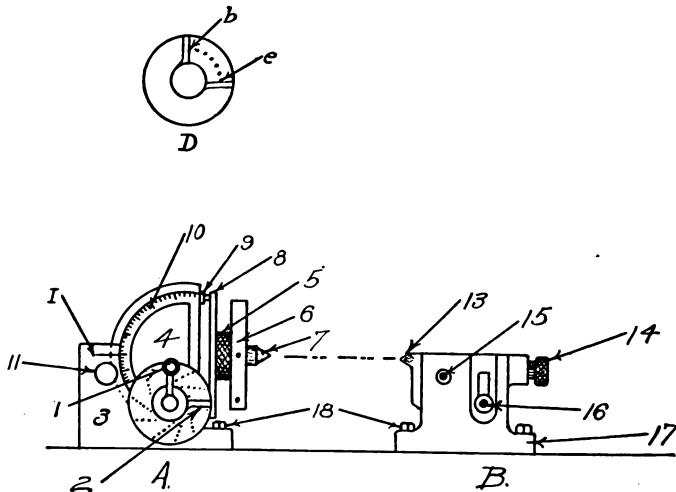

Fig. 178

- | | |
|--|---------------------------------------|
| 1. Index crank. | 9. Index plate locking pin. |
| 2. Sector pieces. | 10. Swivel graduations. |
| 3. Head base. | 11. Swivel clamp bolt. |
| 4. Head swivel. | 12. Footstock center. |
| 5. Spindle collar; this is mounted on and protects the end of the spindle. | 13. Footstock center adjusting screw. |
| 6. Center arm. | 14. Footstock center swivel pin. |
| 7. Center. | 15. Footstock center clamp. |
| 8. Direct index plate; for indexing small number of divisions. | 16. Footstock base. |
| | 17. Table clamp bolts. |

Before turning the work in the vise to finish flange *C*, we will mill the clearance pocket at *F*. This is simply cut out to dimensions called for on the drawings, using the vertical attachment and the same mill we have been

using in finishing flange *B*. The depth gage and scale are used to measure the finished dimensions. The finishing of the flange *C* is a duplicate of the process described for flange *B*. For finishing the ends, the block may be set as for finishing the last flange, and the vertical attachment swung into place so the mill is in a horizontal position, and the ends finished by taking end mill cuts. Dimensions are measured by using the outside caliper. In finishing these end surfaces, the table stops should be used to prevent movement of the table during the cutting operation. The vertical attachment should be looked up in the Brown and Sharpe catalog.¹

Simple Indexing. — The process of simple indexing is one of the most common jobs met on the miller. It introduces to us the milling machine dividing head shown in detail in Fig. 178; at *A* is shown the dividing head and at *B* the footstock. We will study two typical applications of simple indexing at present. In one the centers will be used, and in the other the chuck. For the first job we assume that we are to mill the tongue on a twist drill. Remove all the stops on the machine, take off the vise, and set the dividing head and footstock on the miller table, being careful to clean off all dirt from table surface and bearing surface of dividing head parts. Mount the parts on the table of the miller, and clamp them firmly in place. Oil all parts of the dividing head.

Before starting work we must make a brief study of the dividing head, in order that we may use it intelligently. First find out how many turns of the index handle #1 are necessary in order to turn the index head spindle one complete turn. On most modern millers it requires forty turns of the index handle. All simple indexing is based directly on this relation. With each universal milling machine sent out by the manufacturers, an index card is supplied, for the use of the operator,

¹ Review shaper work for points on shimming and testing work.

214 PRACTICAL MACHINE SHOP PRACTICE

when setting up for indexing. The headings on a typical index card are shown below:

Number of Divisions	Index circle	No. of turns of index	Gear on worm	1st gear on stud	2nd gear on stud	Gear on screw	Lead in inches to one turn	Diam. of cutter mill or drill		
								$\frac{1}{8}$	$\frac{1}{4}$	$\frac{3}{8}$
2	Any	20	24	72	28	86	1.085	20	36	$47\frac{1}{4}$
3	39	$13\frac{1}{3}\frac{3}{8}$								
	33	$13\frac{1}{3}\frac{1}{3}$								
	18	$13\frac{6}{18}$								
4	Any	10								

The meaning of the various headings appearing on this card is outlined below:

“Number of Divisions” means the number of parts into which the circumference of the work is to be divided. In the case of the tongue for the twist drill it is evidently two. If a gear was to be cut, this “number of divisions” would be the number of teeth in the gear.

“Index Circle” means a particular set of holes in the index plate, into which the index pin should set when the index arm #1, Fig. 178, is properly adjusted. If you study the index plates which come with the machine, you will see a set of numbers on the face of each plate. The numbers tell how many holes there are in each circle; for example, the number 18 indicates that there are eighteen holes in the circle located in the line of these figures in the index circle.

“Number of Turns” indicates the movement of the index handle in complete turns, and fractions of a turn, which are necessary, in order to revolve the spindle the proper amount to set the work in the desired position for various cuts. The fraction of a turn is always in the denomination of the number of holes in the index circle. Notice at 2, Fig. 178, the sectors, which are of assistance in setting off the proper fraction of a turn to move the index handle. At *D*, Fig. 178, is shown a view of an index plate, with the sectors in position for spacing a fractional movement of six holes. In use, if the pin were in hole *b* and we were to move $13\frac{6}{8}$ turns, the index handle should be turned thirteen times, and six spaces over, dropping index pin in hole *e*. The operator should then slide the sector along so it is in position for the next movement of the index handle.

Relative to the job we are to do, namely cutting a tongue on a twist drill shank, first select an end mill to give the required radius at the base of tongue; see under *R* in table XII. See that there is no dirt on the end mill shank, nor in spindle or collets. Drive the mill firmly into the spindle using a lead hammer. See that the index lines on the head at *I*, Fig. 178, coincide, and that the movable head of the footstock is tightened, so that the centers are in line. It is a good practice to move the dividing head and footstock up together, so that the centers just touch. By this means, the workman can easily see if the centers are greatly out of line, and make adjustments accordingly.

The work is now mounted on the centers, being sure the head and footstock are properly clamped to the table, and the work run into position for a cut. A center punch mark should be placed on the taper shank of the drill, to indicate the length of the tongue. This mark should be beneath the center of the mill when the lengthwise

feeding is stopped. Use the table stop to hold the table in the proper position after each cut has been made.

Looking at the index card, we see that the number of turns for two divisions is twenty, and we may use any index circle; it is not necessary to set the division sectors for this job, as the index pin is always set into the same hole in the index plate.

Start a light cut on the end of the shank, run up to the position, indicated by the center punch mark on the shank, set the table stop to fix the limit of the cut, back the work off, turn the index handle twenty turns, and run a cut on the surface to the required position, determined by the table stop. Measure the thickness of the tongue thus made with a micrometer caliper, and subtract from this measurement the thickness of the finished tongue. One half the measurement thus found is the amount which must be removed from each face of the tongue, to get the required size.

Looking at the inner end of the handwheel hub #37, Fig. 176, we see a dial reading in thousandths of an inch. By slacking off the binding nut, this dial may be set so it indicates zero in any position of the shaft. The zero on the dial should be set to the index line on the face of the knee, and the binding nut tightened. Raise the table the amount required to conform to the calculation made to determine the finished thickness of the tongue, clamp the knee gib screws at the front of the knee, and run a cut on each face of the tongue. The work should be calipered, and if the dimension is correct the tongue is finished. The machine is apt, under a heavy cut, to show some "spring" so a light finishing cut may be necessary, after the cuts described, in order to bring the work to exact size.

"Straddle Milling." — Whenever more than one milling cutter is mounted on an arbor, the work being operated

upon between the two inner faces of the cutters, the operation is known as straddle milling. In any case, when a number of cutters are used on an arbor, the process is known as "gang milling," so straddle milling is a particular class of gang milling. For accurate gang or straddle mill work, the cutters should remain on the arbor constantly, after they have once been placed, and

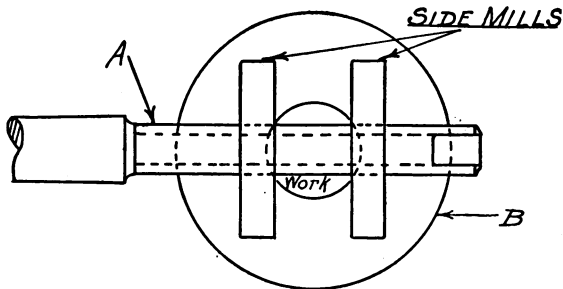

Fig. 182

removed only for purposes of sharpening. Commonly the sharpening and remounting of cutters is done in the tool room. For rough work, permitting a variation of 0.010" to 0.015" this precaution is not necessary. All milled bolt heads, nuts, and a number of other machine parts permit this variation, so a great deal of gang mill work is done with mills mounted for each job, and the cutters removed after the job is completed.

As a study in straddle milling, we will look into the method of finishing a standard hexagonal bolt head, illustrated in Fig. 182. This is to finish $1\frac{9}{8}$ " across flats; place bushings on arbor at A and enough bushings between the cutters to locate the faces of the cutter teeth $1\frac{9}{8}$ " apart. Place the bushings on the remaining portions of the arbor, tighten up the arbor binding nut, drive the arbor in place, being careful to have all parts clean, ad-

just and oil the center, and start the machine. Be sure the cutters run true on the faces, or the work will not be the required size.

The center should now be driven out of the dividing head, the hole stuffed with waste, and a chuck mounted on the spindle nose at #5, Fig. 178. The protecting collar should be removed for this purpose. The chuck is of the universal type; set the work well down in the chuck, tighten the jaws, as described in an earlier chapter, and move the head swivel so the chuck sets horizontally.

All gibs on the machine should be set up closely but not tightly. The work must now be centered relative to the cutters, so that each face of the work shall be equally distant from the center of the bolt; this is done as follows: place the work so it sets beneath the cutters as in Fig. 182; by means of the cross feed screw, set the work so the cutters will remove an equal amount of stock from each side of the bolt head, as nearly as you can judge with the eye. Now by means of the elevating screw, raise the table so that the cutters produce a cut about $\frac{1}{16}$ " deep. Lower the table away, but do not move it lengthwise, turn the index handle twenty turns, and raise the work carefully, so that the work comes to the circumference of the cutters. If the cut previously taken will pass between the cutters without removing any stock from either face, the work is central. If any stock is removed by either cutter, it will be noticed that the opposite cutter is some distance from the face of the work. To correct the error, move the work towards the cutter that is not cutting, one half the distance it stands from the face of the cut previously taken. A second trial cut is now made, and the operation described above is repeated, till the bolt head, by reversing as explained, will enter accurately between the two mills, when we know the head is central.

The workman does not usually make the successive trial cuts, in one position of the bolt head, because the trial cuts might become so deep that they would show on the finished work. The first trial is made in one position, then an index movement is made, and a second trial cut run. When the head is properly located, the table is raised so the cutters will sweep over the whole surface to be finished, and the successive cuts run, indexing between each cut, till the six faces are completed. The process of centering is necessary, only on the first piece of a lot. After the piece is centered, clamp the cross slide gib, so the cross slide cannot be moved, and the machine may be operated without re-setting, as long as machine or cutter arrangement is not changed in any way.

The economic advantage of the gang mill is seen in this job, for we have made but three cuts to finish six faces. Notice that the indexing is set for six divisions, not three. The indexing is always based on the number of divisions wanted on the work when working with straddle mills.

QUESTIONS

1. Name and illustrate the tools commonly used on the miller.
2. Explain the following terms: slab milling; end milling.
3. Give a brief description of the "set up" for a slab milling job.
4. Explain "simple indexing" as applied in milling machine practice.
5. Explain the "headings" found on the index card, in so far as they apply to simple indexing.
6. What is meant by the term, "gang milling"?
7. Explain briefly the "set up" for straddle milling a bolt head.

CHAPTER XII

GEARING

THERE are several different kinds of gears used in the machine shop, but the most common type is the spur gear.

Before the machinist can successfully work on gearing, he must acquaint himself with some of the technical terms which apply to this particular class of work. The "blank" is the piece of material from which the gear is made; the hole in the blank is often spoken of as the "bore" of the blank; the thickness of this blank is known as the "face" of the gear, and the diameter to which the blank is turned in the lathe is known as the "outside diameter" of the gear.

In considering the diameter of a gear we must deal with more than one dimension. The outside diameter is the measurement over the tops of the teeth; this dimension, however, is not the one used in the calculation of running speeds of gearing, but another diameter, somewhat smaller than the outside one, is used for this, which is known as the "pitch diameter," and which is a very important dimension in all gearing calculations. Then, in addition to the two above mentioned, the diameter at the bottom of the teeth must be used at times also. See Fig. 183 for the dimensions to which these various diameters refer.

Now practically all of the dimensions of gearing are related in some manner to the pitch diameter, and one of the much used terms in connection with gearing is "diametral pitch."

It is a well known fact that the circumference of a circle is very nearly equal to 3.1416 times its diameter; since this is true, it is evident that for every inch on the diameter of a circle there must be 3.1416 inches on the circumference. If we regard these linear measurements as related units, which we do when dealing with gearing, then the unit on the circumference is 3.1416 times as large as the unit on the diameter.

It is very convenient when making calculations dealing with gearing to base the work on the diameter, because diametral measurements are conveniently made with simple types of measuring instruments, and the truths just discussed make it possible to use the diameter as the basis of our calculations. Since there are 3.1416 inches in the circumference of a circle for every inch of the diameter, if we place in this space on the circumference a given number of gear teeth, say four, we can easily find the whole number of teeth which can be placed on the circumference by multiplying the number of teeth in this space (4) by the number of inches in the diameter.

Suppose we have a gear blank which is 4" in diameter, and we place 4 teeth in each space in the circumference which corresponds to each 1" space on the diameter, then if we multiply this number of teeth so placed on the circumference by the number of inches in the diameter, the result will give us the number of teeth in the gear.

Now the number of teeth placed in the space on the circumference, which corresponds to one inch on the diameter, is given the specific name of "diametral pitch" in gearing language, and is a term which we commonly meet. Probably one most often hears this unit spoken of as the "pitch," and, unless otherwise advised, he may assume that this term—"pitch" always means the diametral pitch as described above. We may now consider the following as an accepted definition: the diametral

pitch of a gear is the number of teeth on the (pitch) circumference for each inch in the (pitch) diameter.

Whenever the mechanic hears the pitch of a gear mentioned, he has a very good idea of its appearance so far as its teeth are concerned, for, if it be 4 pitch, commonly written 4 P, he knows that for each space 3.1416" long in the circumference there are 4 teeth, as 3.1416" is the space on the circumference corresponding to 1" on the pitch diameter. The catalogue of the Brown & Sharpe Mfg. Co., Providence, R. I., contains cuts showing the comparative sizes of gear teeth, and these cuts may be studied by the young mechanic with considerable profit.

When two gears run together, or "in mesh," the speed ratios are not determined by the outside diameters of the gears, but by the pitch diameters. The extremities of the pitch diameter of a gear are at a point $\frac{1}{2}$ the depth of the tooth, inside the extremities of the outside diameter, see Fig. 183. This pitch diameter is the dimension on which most calculations are based; when two gears are operating, the speed ratios are determined by the diameters of two cylinders, the diameters of which may be regarded as pitch diameters of the gears.

It is evident that two such cylinders in contact would slide on each other, and the motion would not be positive; for this reason gear teeth are placed on these cylinders, one half of the tooth lying outside of the surface of the elementary cylinders, and one half lying inside. That portion which is outside the surface is added to the elementary gear body, and is known as the addendum, while that lying inside the surface is deducted from it, and is known as the dedendum.

Thus we find our tooth divided into two parts by the pitch surface, the outer part known as addendum, and the inner part as dedendum, see Fig. 183. The portion of tooth surface embraced by the addendum dimension is

known as the face of the tooth (not face of gear, remember), while that portion embraced by the dedendum dimensions is known as the flank of the tooth.

Now, relative to the relation of the addendum and the dedendum to the pitch, practice has set the value in fractions of an inch of both these dimensions as equal to

1 divided by the pitch (expressed as $\frac{1}{P}$) in which P equals

the diametral pitch of the gear; from this we see that different pitches have various depths of teeth. If we have a 4 P gear, the addendum will be $\frac{1}{4}$ " and the dedendum $\frac{1}{4}$ ", or the whole depth of tooth $\frac{1}{4}$ " + $\frac{1}{4}$ " = $\frac{1}{2}$ ", thus we see that the depth of the tooth is equal to the addendum and the dedendum added together, or 2 divided by the pitch. We may then assume the following rules to hold true in practice:

To find depth of tooth, divide 2 by the diametral pitch; and

To find addendum or dedendum, divide 1 by the diametral pitch.

Gears of a different pitch will not operate together, so if we have several gears in a set which we expect to run in mesh, all such gears must be of the same pitch, and just what pitch shall be used to do certain classes of work must be determined by the designer. Gear design does not come within the limits of this text, but a simple exposition of this subject is given in the author's book, "Materials and Construction," published by P. Blakiston's Sons, Philadelphia, Pa.

Since we know that the term "pitch" means the number of teeth on the pitch circumference for each inch of pitch diameter, it is clear that if we multiply the pitch by the pitch diameter we will have the number of teeth in the gear; hence the following rule:

Given, pitch diameter and diametral pitch, to find the number of teeth, multiply pitch diameter by pitch.

If we have number of teeth and pitch, we can find the pitch diameter as follows:

Given, number of teeth and diametral pitch, to find pitch diameter, divide number of teeth by the diametral pitch.

If we have number of teeth and pitch diameter, we can easily find the pitch as follows:

Given, number of teeth and pitch diameter, to find the pitch, divide number of teeth by the pitch diameter.

We recall, when discussing the addendum of a tooth, that we found its value in parts of an inch to be equal

to $\frac{1}{P}$; now if we know the pitch diameter of a gear, we

can easily find the outside diameter by adding twice $\frac{1}{P}$

to the pitch diameter, that is, we add the addendum of one tooth to each extremity of the pitch diameter, and we have the diameter to which the blank must be turned in the lathe.

Let us suppose that we have a gear of 16 teeth, and that this gear is to be 4 P; from the previous rule we know that the pitch diameter will be $\frac{16}{4} = 4"$. To get the outside diameter let us add twice the addendum, which in this case is equal to $\frac{2}{4}$, and we have the outside diameter of the gear, which is $4\frac{1}{2}"$. Notice that in order to get the pitch diameter, we divided the number of teeth, 16, by the pitch, 4; and to get the dimension which must be added for the outside diameter, we divided 2 by the pitch and added it to the quotient obtained by dividing 16 by 4. Thus we have calculated as follows:

$$\frac{16}{4} + \frac{2}{4} = \frac{18}{4} = 4\frac{1}{2},$$

or

$$\frac{16 + 2}{4} = \frac{18}{4} = 4\frac{1}{2}$$

From the foregoing we may develop the following rule:

To find the outside diameter of a gear, having given the number of teeth and the pitch, add 2 to the number of teeth and divide by the pitch.

This same analysis applies also to the following very useful rules of gearing:

Having given, number of teeth and diameter of blank, to find the pitch, add 2 to the number of teeth and divide by the diameter of blank.

Having given, whole diameter of blank and pitch, to find number of teeth in gear, multiply diameter by pitch and subtract 2.

The diametral pitch is not the only pitch which the workman must consider. On certain occasions it is necessary to know the relations of various parts of the gear tooth measured on the pitch surface; such measurements are spoken of as the circular dimensions of the gear tooth, and the distance from a point on one tooth to the corresponding point on an adjacent tooth is known as the circular pitch, see Fig. 183.

Now since the diametral pitch is equal to the number of teeth contained in a measurement of 3.1416" on the pitch surface, it is evident that the circular pitch must be equal to 3.1416 divided by the diametral pitch, since this will give as a quotient the distance from the center of one tooth to the center of the next tooth. We have from this process of reasoning the following rule:

Having given the diametral pitch, to find the circular pitch, divide 3.1416 by the diametral pitch.

In looking at a gear we note that for every tooth on the circumference there is a corresponding space. When cutting a gear the mechanic often finds it necessary to measure the width of the tooth on the pitch surface; now on the pitch surface the width of the tooth and the

space are equal, hence if we have 3.1416" on the circumference for each inch on the diameter, one half of this 3.1416" will be space and one half of it will be tooth body, or 1.570" will be space and 1.570" will be tooth. So if we wish to find the width of tooth on pitch surface, since we know that the pitch is the number of teeth in 3.1416" of the circumference, and furthermore since it is a fact that half of this 3.1416", or 1.570", is tooth, then we divide 1.570" by the pitch. We have then the following rule:

To find the width of tooth on the "pitch line," divide 1.570" by the pitch.

This same reasoning enables us to deduce the following rule:

Given the circular pitch, to find the diametral pitch, divide 3.1416" by the circular pitch.

In considering the depth of tooth in the foregoing pages, we assumed that a tooth of a given pitch would exactly fit into a corresponding space, but this is not true, since it is not possible to reach mechanical perfection; hence some extra depth must be added to the theoretical depth; this addition is known as "clearance,"

and is equal to $\frac{0.157}{P}$. For the whole depth of tooth including clearance, related to the diametral pitch, we have $\frac{2.157}{P}$, in which P equals pitch.

This value of whole depth of tooth can be related to the circular pitch as follows: we recall that the circular pitch was shown to be equal to $\frac{3.1416}{P}$, we have also seen that the whole depth of tooth is $\frac{2.157}{P}$, then the ratio of

our whole tooth depth to the circular pitch is

$$\frac{2.157}{P} \div \frac{3.1416}{P} = \frac{2.157}{P} \times \frac{P}{3.1416} = \frac{2.157}{3.1416} = 0.6866, \text{ hence}$$

the following statement:

The whole depth of a tooth equals 0.6866 of the circular pitch.

In applying gearing to service, it is commonly placed in pairs, one gear meshing with another; in this arrangement of a pair of gears, the larger one is usually spoken of as the gear, and the smaller one as the pinion. The mechanic often finds it necessary to determine the proper distance apart at which gear centers may be located in order that they shall run properly.

Looking at Fig. 183 we see that this distance must be equal to the sum of the pitch radii, and we recall that the pitch diameter equals the number of teeth divided by the pitch, and the pitch radius of each gear will equal $\frac{1}{2}$ the number of teeth in each gear divided by the pitch. Adding the values thus found will give us the required center distance; hence we have the following rule:

To find the distance between centers of two gears, add the number of teeth together and divide half the sum by the diametral pitch.

Gears made in the machine shop are commonly cut in the milling machine; other methods of producing gears in large quantities are by means of the automatic gear cutter and the gear shaper. As the two last named machines are of a specialized variety, they will not be considered in the present chapter, since the cutting of a gear in the milling machine presents all the elementary steps of the work.

Assuming that the gear blank has been properly turned and mounted on a mandrel, the first step is to select the proper cutter. Gear cutters are of two general varieties,

namely, involute and epicycloidal; the involute cutter is in such common use that it may be regarded as the accepted system of practice; nevertheless, occasionally the mechanic must cut gears having epicycloidal teeth, hence the cutter for this form of tooth will be briefly discussed later on.

First, relative to involute cutters, we must understand that one cutter will not cut all numbers of teeth, even though all the wheels we wish to cut are of the same pitch. For example, if we are to cut a gear of 12 P having 20 teeth, we must not use for this the same cutter which would serve us when cutting a gear of 12 P, 130 teeth. We therefore have a range table for the various cutters, each cutter having a specific number, and a certain range of teeth is allowed for each of these numbers, as follows:

Involute Cutters.— Eight cutters are made for each pitch, as follows:

No. 1	will cut wheels from 135 teeth to a rack.
“ 2	“ “ “ “ 55 “ “ 134 teeth.
“ 3	“ “ “ “ “ 35 “ “ 54 “
“ 4	“ “ “ “ “ 26 “ “ 34 “
“ 5	“ “ “ “ “ 21 “ “ 25 “
“ 6	“ “ “ “ “ 17 “ “ 20 “
“ 7	“ “ “ “ “ 14 “ “ 16 “
“ 8	“ “ “ “ “ 12 “ “ 13 “

Studying this table, we see that if we wish to cut a gear having 135 teeth or more, we use a #1 cutter; this is also serviceable if we wish to cut a rack, which is nothing but a series of gear teeth cut on the face of a straight piece of stock, see Fig. 183 B. If we wish to cut a gear having any number of teeth between 55 and 134 inclusive, we will use a #2 cutter. Now a set of these cutters is made up for every pitch of gear in common use. Gear

cutters are commonly purchased from manufacturers who make a specialty of this line of work, and have facilities for producing a very accurate tool.

If we have read the preceding text carefully, we know that when asking for a gear cutter, we must state the pitch and range of teeth necessary for the gear on which we are working. In order to save time, the workman should also state the diameter of hole required in the

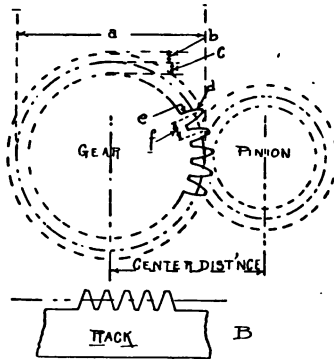

Fig. 183. Gearing Details

- a. Indicates the pitch diameter.
- b. Indicates the addendum.
- c. Indicates the dedendum.
- d. Indicates the tooth face.
- e. Indicates the tooth flank.
- f. Indicates the circular pitch.

The teeth on these gears and on the rack are enlarged out of proper proportion to size of blank, for the purpose of illustration.

cutter, so that it may properly fit the arbor of the milling machine.

The epicycloidal cutter is but rarely used in cutting gears. For certain classes of work, however, the designer uses the epicycloidal tooth because of its smoother action, and therefore the young machinist should be familiar with it. So far as the setting of this cutter in the ma-

chine is concerned, it is in no way different from the process necessary for the involute cutter. The range table for these is related to the alphabet instead of to numerals, as follows.

Epicycloidal Cutters. — Cutters are marked with letters, and there are 24 cutters in each set.

Cutter A cuts	12 teeth	Cutter M cuts	27 to	29 teeth
“ B “	13 “	“ N “	30 “	33 “
“ C “	14 “	“ O “	34 “	37 “
“ D “	15 “	“ P “	38 “	42 “
“ E “	16 “	“ Q “	43 “	49 “
“ F “	17 “	“ R “	50 “	59 “
“ G “	18 “	“ S “	60 “	74 “
“ H “	19 “	“ T “	75 “	99 “
“ I “	20 “	“ U “	100 “	149 “
“ J “	21 to 22 “	“ V “	150 “	249 “
“ K “	23 to 24 “	“ W “	250 or more	
“ L “	25 to 26 “	“ X “	Rack	

In calling for these cutters at the tool room or on requisition, the workman must give the required range letter, pitch, and diameter of hole.

The milling machine should be set up for cutting a spur gear in the same way it was set for cutting the tongue on the twist drill. Cutters carefully adjusted, no dirt on parts, and everything well oiled. The stop for lengthwise movement is not necessary. Looking at the gear cutter, Fig. 184, we see a line marked on the surface at A. This line is the center of the forming faces of the cutter, and it is used for setting the cutter in the proper position for cutting the gear teeth, as illustrated in Fig. 184. The table should be raised, and the footstock center placed directly in line with the mark on the face of the

cutter as shown in the illustration; this is one of the first steps in cutting a gear. Tighten the cross slide gib screws so the cross slide cannot be moved after this setting has been made.

The table is now lowered, and run back, leaving room to place the mandrel having the work properly mounted,

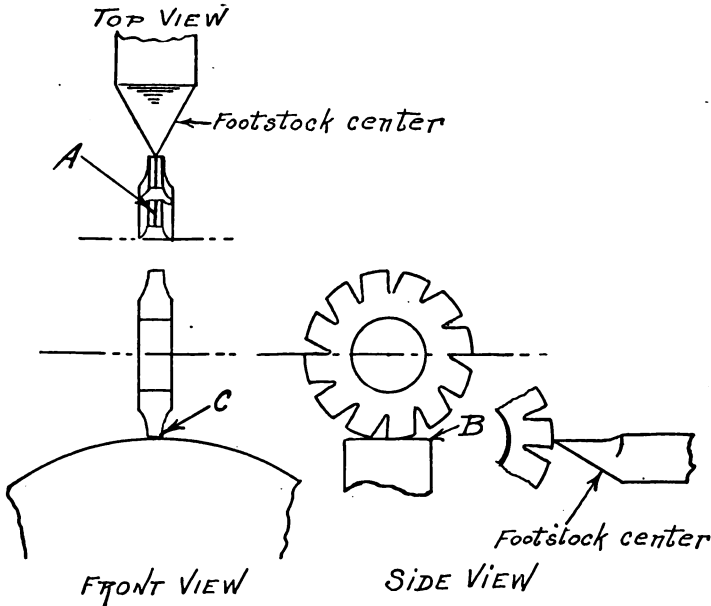

Fig. 184

on the centers; tighten the center arm binding screw on the tail of the dog so there may be no play. We must now set the index for the proper movement of the blank in cutting the teeth; suppose we wish to cut 39 teeth in this gear; looking at the index card we see that we may use a 39 index circle, and that the index crank should be moved one turn and $\frac{1}{39}$ th of a turn over, so we set the sectors to permit a movement of one space, that is the

distance between two holes on the 39 circle. When counting off a spacing on an index circle, always count the spaces between the holes on the plate, as it is the space that determines the movement of the index handle.

Being properly set up, we now run the work up so the cutter just makes a slight mark on the edge of the gear as at *B*, Fig. 184, draw the work back, index, and mark the next tooth; continue this operation around the whole circumference of the blank, and count the marks made; if these marks are the same in number as required for the teeth in the gear, your indexing is correct; if they do not agree, look for an error in your index "set-up," and correct it. The operation just described is known as "spotting the blank."

The next step consists of bringing the blank in position so the cutter just touches the surface as shown in Fig. 184 at *C*; run the work back so it is free from the cutter, set the micrometer dial on the table elevating screw to the zero point, and raise the knee an amount equal to the full depth of the tooth. The cutting may now be proceeded with, going completely around the gear, and letting the cutter run completely across the face of the blank at each pass. As the cut is started on each tooth, notice whether or not it coincides with the small mark previously made when spotting. Occasionally a gear blank slips on the mandrel, and the cutter does not enter the spotting mark. If this is noticed in the process of working, operations should be stopped at once, the gear driven more solidly on the mandrel, and the blank reset in the machine. In resetting, the blank should be turned back, by means of the index handle, so that the cutter is true in a space five or six divisions back of that on which the error was noticed, and cutting proceeded with from that point. There are a number of operations carried out on the miller as the machine is

adapted to many special operations. Most of the work is related directly to slab milling, end milling, gang milling, or indexing, and in the preceding text we have studied these processes. The calculations underlying the index table, which was used in setting up the index of the machine, will be taken up in the chapter on calculations.

In looking at the index card the learner will notice other entries, specifying the use of gears; these data deal with the cutting of helical or "spiral" cutters and gears. The subject is of a more advanced nature than the material logically finding a place in the present text, and it is reserved for treatment in a more advanced work.

QUESTIONS

1. Explain the following terms as applied to gearing: blank; bore; face; outside diameter.
2. Explain your understanding of the term, "diametral pitch."
3. Explain the following terms as applied to gear teeth: addendum; dedendum; face; flank; circular pitch.
4. Explain the meaning of the numbers used in classifying involute cutters.
5. Give a brief description of the "set up" for cutting a spur gear on the miller.

CHAPTER XIII

THE PLANER

THE planer is used in modern shop practice, for the same purpose as the shaper, which we have already studied. The planer accommodates much larger work than the shaper, is capable of carrying heavier cuts, and, while the general principles of operation are the same, the detail of handling the work is somewhat different. The same classes of cutting tools are used on the planer as on the shaper, so the learner may refer to the chapter on shaper operation to refresh his mind on the tool classification. Vise work is handled on the planer in the same way that it is carried out on the shaper, so this subject will not be presented again.

A view of a modern planer is shown in Fig. 185. The learner should study this figure carefully, as he has been advised to do in connection with other machines. In starting the machine, handle all parts, and become acquainted with the functions of each, before attempting to do a job. Be sure to oil all parts of the machine, not forgetting the main and auxiliary driving shafts inside the bed. In some designs this machine has two traveling heads mounted on the rail. These are of service on many occasions when the workman wishes to run a vertical cut on two faces of work, or one vertical and one angular cut, or in certain cases, two surface cuts.

The most of the work done on the planer is platen work, that is, the work is mounted directly on the platen of the machine, and clamped to it, while the cut is being taken. Before starting to study a specific job, it will be

well for the beginner to become acquainted with some of the clamping devices used, and a few features of operation which apply particularly to the planer.

A great deal of planer work consists of planing surfaces flat and true, and for some of this work the vise is used. The pinch strip is used very successfully for this work, as shown in Fig. 186. It is simply a thin piece of metal about $1\frac{1}{2}$ " wide, and $\frac{1}{4}$ " thick, planed parallel on the edges, the heel of which sets into grooves in the vise jaws. The jaws are closed by means of set screws *d*, the jaw holding down bolts *b* being set down closely but not tightly while the jaws are tightened. The pinch strips setting in the grooves *c*, it is evident they cannot rise, so the work is pushed down by the edge *f* of pinch strip. A stop must be used on heavy cuts, to prevent the work sliding endwise. After setting up screws *d*, clamp bolts *b* are tightened solidly.

Much surface planing to be done is too large to hold in the vise; in Fig. 187 the principles of pinching work to the platen are illustrated. The piece *a* is called a rib piece; the tongue *b* should make a close fit in the platen slots, and the bolts *c* clamp the rib piece firmly in place. Here the work is forced downward on one edge only, by means of the pinch stop *d*. This scheme works out very well, if the piece being planed is comparatively thick, but if it is thin, it tends to rise at the edge setting against the rib, and the workman has difficulty in producing accurate work. Figure 188 shows an application of the pinch strip to the rib piece, which enables the workman to get excellent results on thin flat pieces.

The strip *a* is bolted solidly to the platen by means of the bolts *b*, and pinch strip *c* rests in a groove in this strip. Strip *d* is a sliding piece with elongated slots as indicated at *e*; bolts are inserted in the planer T-slot, *g*, and set down just closely enough to permit this strip

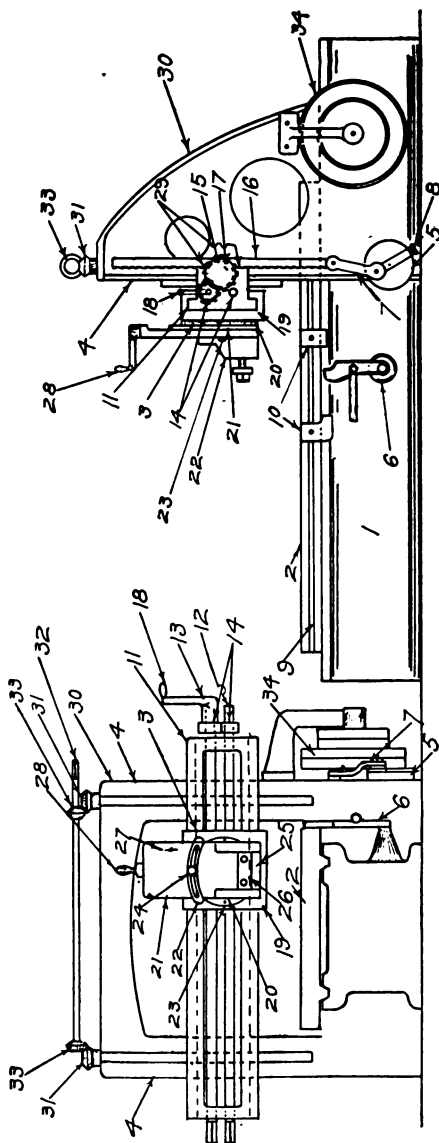

Fig. 185

1. Bed.
2. Platen or table.
3. Rail and head.
4. Uprights.
5. Feed friction disk.
6. Table stroke tripping lever; may be operated by hand when desirable.
7. Feed operating rod.
8. Feed adjustment knob and screw.
9. Slot permitting setting of trip dogs at desired points along table.
10. Trip dogs; for reversing table at desired points.
11. Cross rail; main casting.
12. Cross rail feed screw.
13. Vertical feed rod.
14. Vertical and horizontal feed gears; slipped on and off rods as may be necessary; not often used at same time. On some machines only one "slip-gear" is furnished, and this is placed on either horizontal or vertical feed as operator may desire.
15. Feed driving gear.
16. Feed driving rack.
17. Feed trip latch; used to throw the automatic feed in and out of action.
18. Hand crank for operating vertical and horizontal movement of head by hand.
19. Apron.
20. Swivel; graduated in degrees to permit taking of angular cuts.
21. Vertical slide.
22. Clapper box.
23. Swivel clamp bolts.
24. Clapper box clamp bolt.
25. Clapper block.
26. Tool clamp bolts and clamp.
27. Vertical slide lock; used to prevent vertical movement of the head, when taking surface cuts.
28. Vertical slide crank handle; for operating vertical slide by hand. This slide may be operated either by rod #13 or directly by means of handle #28. Commonly when a considerable movement of the slide is necessary, the rod #13 is used, while for small movements the hand crank #28 is used. Rod #13 is operated by means of handle #18, the end of the rod being squared to fit the handle; this handle fits the cross feed screw #12, and is used on either vertical feed rod #13 or cross feed screw #12.
29. Rail clamping bolts.
30. Uprights; main castings.
31. Elevating screw gears.
32. Elevating rod; crank handle #18 is used here to raise and lower the cross rail.
33. Elevating rod gears.
34. Driving pulleys; one set for cutting stroke and one for quick return of table.

to slide on the platen without lifting. The stop blocks are inserted in the next T-slot, and the screws *k* set against the sliding strip *d*. The pinch strip *m* is placed and the screws *k* set up firmly, after which the strip *d* is bolted solidly to the platen. Stop clamps should be

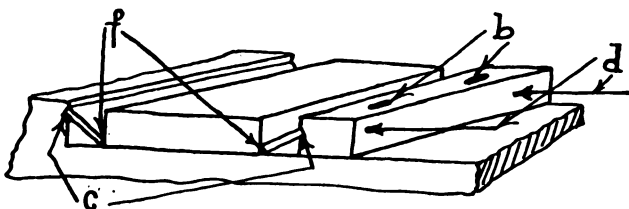

Fig. 186

used at the end of the work, to prevent sliding when the cutting action is in progress. By having a number of widths of strips *a* and *d*, and several widths of pinch strips, any width of work may be handled.

At Figs. 189 *D*, *E*, *F* and *G* are shown some other fixtures that are useful to the planer hand; at *D* is seen

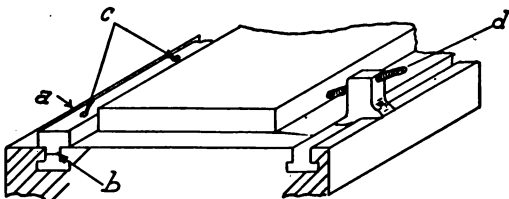

Fig. 187

a stop stake; this is placed in the holes in the planer platen, and prevents the work from moving under the cut. At *E* is a pinch stake; this is placed in the hole in the platen, and serves to pinch work down to the table; it is a very satisfactory pinching device, if the work is sufficiently thick to permit its use. At *F* we have a stop block, used in the cross, or lengthwise T-slots of the

platen to prevent movement of the work under the cut. It serves the same purpose as the stop stake *D*, but it fits in the platen T-slot, instead of in a hole in the platen. The pinch block *G* is used for the same purpose as the

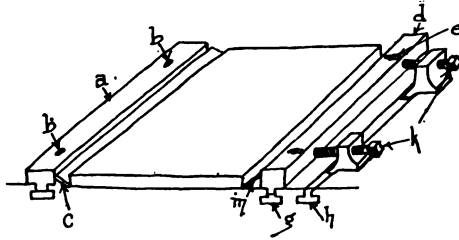

Fig. 188

pinch stake, but it fits the platen T-slot instead of a hole in the platen.

Figure 190 shows a number of other pieces of clamping equipment, necessary for the planer. At *A* is shown a clamping block; these are used under the outer ends

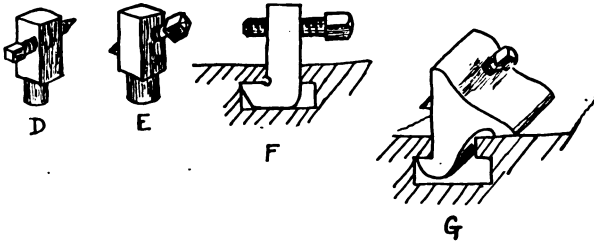

Fig. 189

of clamps, the other end bearing on the work and holding it in place. Not all shops have this equipment; the workman uses any piece of stock he can pick up, when clamping blocks are not available.

At *B* is shown a planer jack; this is very useful under work, on certain occasions, when it cannot be supported

satisfactorily without such equipment. Very often one is called on to plane a piece of work having an overhanging portion. In order to support the surface to be planed in the proper position, a jack is placed beneath this overhanging section of work. At the right of the figure are shown various kinds of clamps; *a* is a straight strap clamp, *b* is a bent strap clamp, *c* is a straight horse shoe clamp, *d* is a pin point clamp, *e* is a goose neck

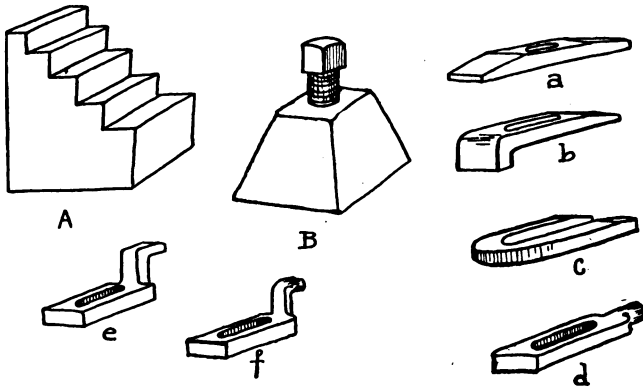

Fig. 190

clamp, *f* is a pin goose neck clamp. "Pin" clamps are also known as "finger" clamps, and "horse shoe" clamps are sometimes called U-clamps. Each type of clamp serves a specific purpose in planer practice, and is used as the judgment of the workman dictates. In setting a clamp on the work, one should be particular not to have it bear at an angle on the surface, but set square and come down to an even seat, on both the work and the blocking. Parallel wedges are much used on the planer as well as on the shaper. An illustration of their use was given in connection with the shaper. Clamps, pinch fingers, screws, and pinch strips are usually of machinery steel; rib strips are of cast iron.

At times the workman will find the pinch fingers and stakes shown in Fig. 191 very convenient. Used in connection with a beveled strip, as illustrated, one is enabled to hold a great many pieces of work more easily than by any other means. At *S*, of this figure, is illustrated an arrangement of pinch clamping. Occasionally the worker finds this method of holding work very serviceable, when no other is available.

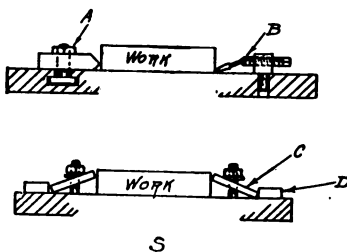

Fig. 191

After the learner has familiarized himself with the planer and its equipment, there are a few tests to be made before starting work, if accurate results are expected. The table should be tested for the crosswise or

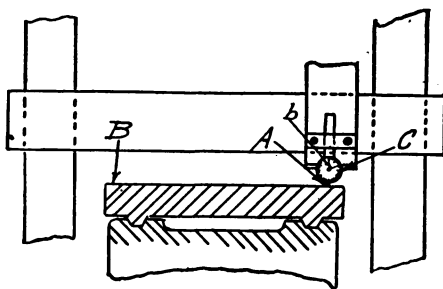

Fig. 192

transverse movement of the head. To do this, set an indicator in the clapper block, and clamp firmly in place as shown in Fig. 192. Move the head so the indicator needle may be placed on one extreme edge of the table as at *A*; run the vertical head slide down till the dial needle *b* on the indicator shows a reading. It is not important what this reading is, but about twenty thou-

sandths is suggested. Now without moving the vertical head slide lift the clapper block by hand, and run the head across the rail so the indicator needle will touch at *B*. If the cross rail and table are accurate, the reading of the indicator should be the same at position *A* and *B*. If it is not the rail must be adjusted; the beginner should not attempt this adjustment without advice from the party in charge of the work, but the method of adjustment will be explained. Looking at 31 and 33, Fig. 185, one will see a bevel pinion and gear; one of these is held in place by means of a set screw. To adjust the cross rail, slack the set screw on the gear or pinion which would raise the end of the rail that is too high, as shown by the test, and, by means of the elevating shaft, raise the low side of the rail the proper amount to show an equal reading at each end of the rail. Clamp the gears by means of the set screw just mentioned, raise the rail about one turn of the elevating shaft, and repeat the test. When adjusting a rail, always correct errors by raising the low end of the cross rail, rather than lowering the high end. When taking readings, always see that the clamp bolts which hold the rail to the uprights are tightened solidly.

In working on the planer, the cross rail must be raised and lowered, to accommodate the height of the work. Whenever the rail is lowered, it must be run down below its working position, and raised slightly, in order to eliminate backlash. The upward and downward movement of the rail is obtained by turning the elevating shaft, #32, Fig. 185, in the proper direction. A few turns one way or the other will show the direction in which the rail is moving, and the operator is governed accordingly.

In connection with the testing of the planer, it may not be possible for the workman to obtain an indicator, in which case he may use a round nosed tool, and place a piece of paper between the cutting point of the tool

and the platen, adjusting the vertical slide till the tool just holds the paper without tearing, when it is drawn from between the tool and platen, with the hand. The rail should be adjusted till the same effect is obtained at both edges of the platen.

Relative to the lengthwise adjustment of the platen, the test indicator or tool should be mounted on the clapper block as already described, and the platen run

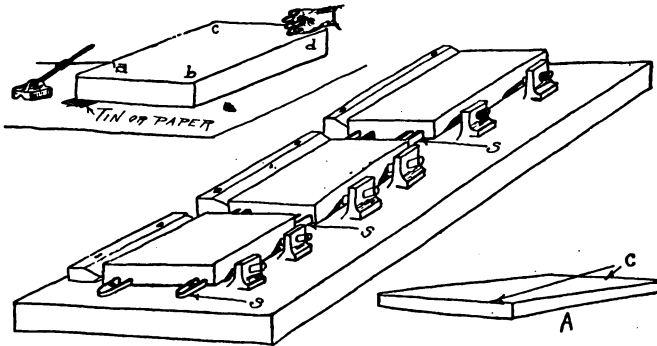

Fig. 193

"Set up" methods on the planer.
S indicates a stop clamp.

all the way back, so the indicator touches on the extreme front end of the platen. A reading is taken here, and the clapper block lifted, while the platen is run along the bed so the indicator will touch at the extreme rear end. If the readings are not the same within required limits of accuracy, the platen must be trued up, by running a cut over it, assuming that the machine is properly set on its foundations. A cut should not be taken from the platen, unless you are authorized to do so by the party in charge of your work.

Two illustrative jobs will be taken up on the planer, one showing a "set up" for "stringing" the work, and

the other an angular job. The principles of most other elementary jobs have been presented in connection with the shaper, and the method of working on the planer, for similar types of jobs, does not vary from that described for the shaper. At *A*, Fig. 193, is shown a steam engine part which is to be produced in quantities; it is a flat, rectangular plate, and must be accurately finished all over.

In working these pieces, without any special fixtures other than the usual planer equipment, we will pinch them down, using a bevel rib strip, and pinch blocks. If we did not have this equipment, it would be possible to hold the work by means of the pinch clamping arrangement illustrated in Fig. 191. Notice that short stop clamps are used between each piece and a couple of heavy stop clamps are used at the end of the last piece.

In setting up pieces of this sort, as in setting up all work on the planer, the operator must see that the piece is properly supported on the platen, so there is as little tendency as possible for the work to spring. Furthermore all the pieces must be approximately the same height, as they set on the planer. The workman sets a plate on the machine platen, and strikes it lightly with the fist, at one of the corners, as indicated at *d*; this operation is repeated at all four corners. In all probability it will be found to rock back and forth slightly when tested in this manner. To prevent this, the machinist puts pieces of paper or tin under the corners as indicated, and with the surface gage as shown in the figure all four corners are set as nearly the same height as possible, by moving the shimming as may be necessary. All plates are set in the manner indicated, and properly shimmed up, after which a roughing cut is run over them.

When this first cut is taken from the work it should remove all the outside rough surface or "scale"; if it

does not, enough cuts must be taken to do so, and leave a reasonably true surface. The pieces being described were required to be true, when they were finished. Now when the outside rough surface is taken from a piece of metal it changes shape, or "springs" as the machinist says; for this reason we do not take the finishing cuts

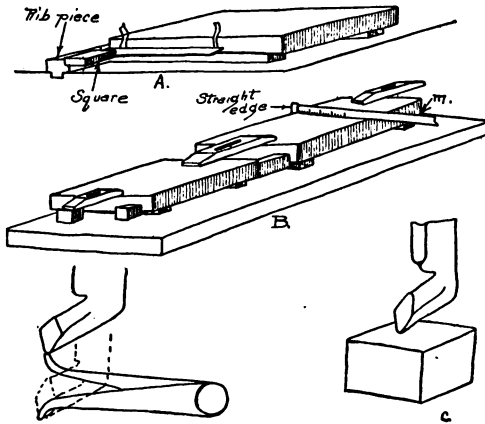

Fig. 194

from the surfaces being worked, but turn the pieces over, and rough out the opposite face. This springing of work when removing the scale is not serious on a heavy body, but on work which is thin, in comparison to the area, it must be carefully guarded against. When the pieces are turned over, and laid flat on the platen, the workman should strike it with the fist as previously described. The piece will jar slightly; this is really the rocking of the piece on the platen, and this jar must be eliminated by shimming under the corners of the work, with pieces of paper. This process must be carried out with each plate as it is set up, when it may be pinched down and roughing cuts run over the surfaces removing all but

about $\frac{1}{8}$ " of the stock. The edges of all these plates are next finished by clamping on parallels, and taking down cuts, using both vertical heads, one cutting on each edge if the planer is equipped with two heads. These edges may be brought to size at one setting, the only precaution necessary being to slack off the holding clamps after the roughing cut. The finishing cuts should be taken with the work clamped rather lightly, on all occasions, in order that the work may not show "spring." In planing the edges of these plates they must be "lined up," before starting the cut. This is done by pushing them against a rib piece as shown in Fig. 194 *A*; this rib piece is removed before cutting is begun. The measurement for size on this class of work is usually made by using a straight edge and long steel rule obtained from the tool room; see *B*, Fig. 194, at *m*.

After the longer edges of the plates have been planed, the ends *c*, shown at *A*, Fig. 193, must be finished; these ends must be square with the longer edges. The new feature in this set up is the squaring of the plates on the platen so they will be true when finished. This is done as shown in Fig. 194 at *A*. A rib piece is set in a slot in the platen, and the hilt of a square rested against it. Pieces of paper are placed against the finished edge of the work and the blade of the square brought up to it; the work is clamped lightly, and knocked into such a position with a lead hammer that the two pieces of paper at extremities of the square blade are held securely in place, when the blade is brought against the work. The piece nearest the forward end of the platen is set first, then those towards the rear end set; space enough should be left between the pieces to permit the square blade to be inserted for final testing after the pieces have been clamped in place. Stop blocks should be used between the plates, and behind the last plate as shown at Fig. 193.

After running a cut over the ends of the work, it should be tested with the try-square, before reaching the finished dimension, in order to be sure that the short edge is planing true with the long edge. If it is not, the work must be reset again. The final measurement for length is made in the same manner as described for final width measurement.

The work is now roughed out all over, and finished on the edges. The final job is the finishing of the flat surfaces. The plates are pinched down again, the same as for the roughing cut shown in Fig. 193 but not so solidly. They are tested for rocking by striking with the fist, and shimmed so they set perfectly solid on the platen, before pinching down. A cut of about 0.015" is run over the first surface, using a shovel nose tool and a feed of from two to four teeth, followed by a light cut of about 0.003" and a feed of about eight or ten teeth. The plates are then turned over, and all but about 0.015" of the thickness removed with a roughing tool, and two light finishing cuts taken as described above, and the planing on the plates is finished.

The method described will produce a plate that is quite true, and will not require an undue amount of scraping to bring it to an accurately true surface on the surface plate. When such accuracy is not necessary, the work may be lessened by running the roughing and finishing surface cuts successively, instead of roughing out, all over, first, and then finishing. A plate thus planed will always show some spring, but it is satisfactory for a great many purposes.

The final thickness of work of the kind described is determined by setting the tool to a gage block, as illustrated at *c*, Fig. 194, the tool being brought down so the gage block is just held in place by the tool. The tool should never mark the block in any way. Sometimes it

happens that a workman may have a size to plane, for which he does not have a gage block, and under such circumstances the inside caliper may be used as shown at Fig. 194 D. The inside caliper is first set to the thickness which is to be planed, either on a scale, or from outside or micrometer calipers. The tool is run down so it just touches the planer platen, and a cross mark made on the platen at the point of the tool. This setting is shown by the tool in dotted lines of the figure. The mark made

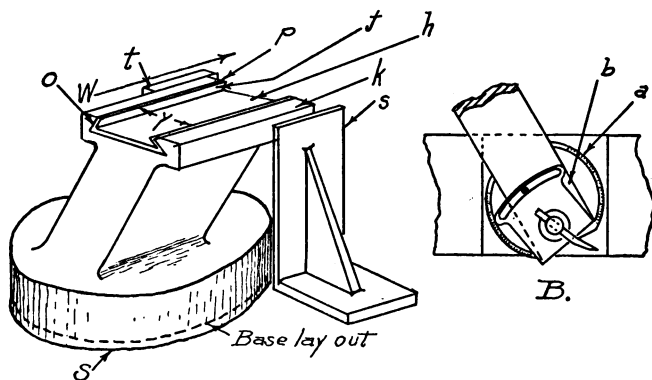

Fig. 195

with the scratch awl gives the point at which one leg of the caliper must always set when making measurements. Without moving the tool in any direction except vertically, it is run well up from the platen, then run down again till the caliper will just pass between the marked point on the platen, and the point of the tool. The marking of the platen is necessary, in order that one may be certain of having the point of the caliper which rests on the platen directly beneath the point of the tool. This method of setting requires some skill, but very good results can be obtained after some practice. The work itself should always be measured, as a final test, before

it is taken from the machine. Use a depth gage for measuring on the machine.

The second illustration to be studied is part of a fixture for turning handwheel rims. The work is shown in Fig. 195, and it offers some interesting "setting up" work, as well as introducing angular down cutting. The piece is first set on the platen as shown at Fig. 196, in order that the base surface *S* may be planed. The work should be trued up by shimming under the corners, so that surface *S* is true when tested with a surface gage. Clamps should be placed at the corners, *a*, *b*, *c* and *d*, while a jack should be placed at *f*. Place a stop at *e* to prevent the work from sliding. Before setting up any work of this sort it should be completely laid out, including the base, bottom of planed surface *h*, Fig. 195, angular

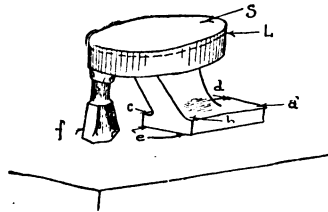

Fig. 196

surface *J*, and surface *k*, Fig. 195. The workman then knows just how much stock may be removed from each surface. In setting up, as in Fig. 196, for planing surface *S*, the work should be set up to layout *L*. Roughing cuts are run, the various holding clamps slacked off and a light finishing cut taken. The work is now removed, and the surface *S* set on the planer platen, clamped lightly, and the work set true to layout for surfaces *h*, *j* and *k*, Fig. 195, using the scribing tool which was mentioned in connection with the slotter, in order to bring the work true to the travel of the table. No shimming should be placed beneath surface *S* on this set up; the only setting necessary being that required to set layout line *op*, Fig. 195, true with the movement of the table. In addition to holding down clamps, and a couple of stop

clamps to prevent the work from sliding along the platen, two knees should be placed as at *s* and *t*, to prevent the work from turning. In setting the work, arrange it so the tools cut in the direction of the arrow *w*, Fig. 195. If the stress is taken in the opposite direction, the work is more apt to spring and cause the tools to "bite," or chatter badly.

The only surfaces to be finished are *h*, *j*, and *k*. The start should be made by finishing the surfaces *h* and *k*, so that the distance of surface *h* from surface *s* is about $\frac{1}{32}$ " too great. This is measured carefully with a scale and straight edge, or with a surface gage set from a scale. The angular surfaces *j* should be roughed out next so that the distance *y* is about $\frac{3}{32}$ " smaller than finished size. Distance of surface *k* from surface *h*, is measured with a depth gage.

The setting of the planer head for taking the angular cut is shown in Fig. 195 *B*. The angle to be planed is 30° from the vertical; the swivel *a* is set to this angle. The clapper box *b* is swung an added amount as shown, to give the required freedom of the tool in action. This setting of the clapper box in no way affects the angle of the cut, as the tool travels to the setting of the swivel. Be sure both swivel and clapper box are bolted firmly, after making the various settings. When finishing into the corner of the angle, at the point of meeting of surfaces *h* and *j* the operator should work very carefully, using the cross and angular movement of the machine, always feeding by hand, in order that the work may not be spoiled. After roughing out, all the surfaces are finished to dimension with light cuts.

QUESTIONS

1. In view of the fact that the shaper is a planing tool, why is the planer necessary?

2. Give your understanding of the following terms: surface cutting; down cutting.
3. Illustrate and describe the various clamping devices used on the planer.
4. Explain the use of " stop clamps " in planer practice.
5. What do you understand to be the meaning of the term spring? How do you plan to avoid it?
6. Briefly describe the tests to be made on a planer before starting work.
7. Mention some important points to be observed when setting the planer for angular cutting.

CHAPTER XIV

MACHINE SHOP CALCULATIONS

THE subject of mathematics is very important to the skilled mechanic. If he understands the more elementary branches, a great many calculations are very clear; if he does not have a knowledge of mathematics, he must do much of his calculation in an imitative sort of way, not knowing the reason for taking certain steps, with the result of making many errors. This text will not deal with mathematics, as such, but will cover certain specific calculations in a practical way; as to the branches of mathematics which the ambitious mechanic will find of assistance, one may mention arithmetic, algebra, geometry and trigonometry.

Our first study will be the analysis of the vernier scale. As the student has seen, this scale has a great many applications in the machine shop to calipers, depth gages, height gages and angular measuring devices. The vernier scale is named after the inventor of the device; it consists essentially of two parts, the beam and the scale. By a proper arrangement of the divisions on the scale and beam, a very small fraction of a given measuring unit may be obtained. In the case of linear measurement, it is the inch that is divided, while in the case of angular measurement it is the degree. In the Metric system of linear measurement, the millimeter is the unit that is divided.

In the construction of a vernier the following plan is observed. A certain number of divisions is laid off on the beam embracing the unit to be divided. A certain length is laid off on the scale, embracing a certain num-

ber of the units on the beam; the number of beam units thus embraced is decided by the final division sought, by the use of the vernier. The section laid off on the scale is divided into one more part than there are parts in the corresponding length on the beam. This extra division enables one to obtain the desired minute measurement.

As an illustration let us take a length of one inch on the beam, which we divide into ten equal parts. Now take a space on the scale, equal in length to nine of these divisions; it is evident that our scale is $\frac{9}{10}$ of an inch long. Let us divide this $\frac{9}{10}$ of an inch into ten equal parts; a little thought will make clear the fact that each division on the scale is $\frac{1}{10}$ of $\frac{9}{10}$ of an inch long or $\frac{1}{100}$ of an inch long. Each division on the beam is $\frac{1}{10}$ of an inch long or $\frac{1}{100}$ of an inch, so we have a difference of length between a division on the scale, and a division on the beam of $\frac{1}{100}$ of an inch. This simple explanation presents the method for laying out any vernier scale for linear measurement. In looking over the steps we have taken, we note that by multiplying the denominator of the fraction into which we divided the unit on the beam, by the number of parts into which we divided the scale we obtain the denominator of our final fraction of measurement. To explain; we divided the inch on the beam into ten equal parts; we divided the space on the scale into ten equal parts; ten times ten equals one hundred, or the denominator of the final fraction which we may possibly obtain by the use of our vernier. We may then make this rule for laying out a vernier: Divide the denominator of the ultimate fraction desired, by the number of divisions into which the unit on the beam is divided and we will find the number of divisions which must be used on the scale. The total length of the scale should be equal, in length, to the number of beam divisions indicated by this quotient, less one.

Now let us apply this rule. We are to lay down a vernier which shall measure the $\frac{1}{100}$ part of an inch. We may take any numbers we wish, which will assure us an even number of divisions for the scale. Suppose we divide 100 by 4, we have 25; this is the number of divisions that must be used on the scale, namely 25, and each inch will be divided into 4 equal parts. The total length of our scale must be equal to $24 \times \frac{1}{4} = 6''$. Our vernier then demands a scale which is 6" long, divided into 25 equal parts, and each division on the beam is $\frac{1}{4}''$ or 0.25" long; each division on the scale is $\frac{1}{25}$ of 6" = 0.24", hence each scale division is $\frac{1}{100}''$ shorter than the beam division, and we have solved our problem.

The scale is too long, however; the instrument will not be convenient for use. By simply dividing the beam unit into a greater number of parts we can reduce the length of the scale to more convenient dimensions. Apply the rule evolved to ten parts of the beam unit and it will be found to produce the scale used in our first illustrative study. The outline given can be followed in laying down any linear vernier. The vernier scale commonly used in machine shops does not read to hundredths of an inch, but to thousandths. The beam is constructed with forty divisions to the inch; thus each division on the beam is 0.025" long. The limit of the scale in length is made twenty-four of these parts, and the scale is divided into twenty-five equal parts. If the rule which we have developed is applied we will find that the space on the scale is $\frac{1}{1000}''$ shorter than the space on the beam.

In the case of the metric vernier the beam division is taken as half a millimeter. Twenty-four of these beam spaces are covered by the scale, and the scale is divided into twenty-five equal parts, making each scale division $\frac{1}{25}$ of $\frac{24}{2}$ mm. or $\frac{24}{5}$ mm. The beam division is $\frac{1}{2}$ mm. or $\frac{5}{10}$. The application of the rule for laying down a

scale is varied, in this case, from that given for English scale, but the rule is unchanged. The application is explained in connection with the angular vernier, so it will not be given here.

Reading the Linear Vernier.—The 0 mark on the scale is the first point to be observed in reading this instrument. The position of this point gives us at once the number of inches and larger fractions of an inch to which the instrument is set. The odd thousandths are read from the scale, using a magnifying glass. Looking

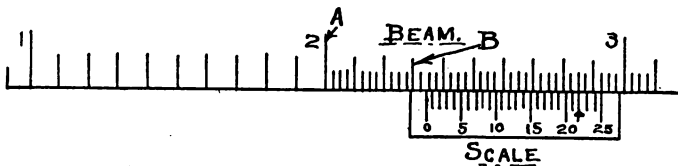

Fig. 197

at Fig. 197, we see that the 0 on the vernier scale is past the 2" mark at A, and the three tenths mark at B. It is just beyond the 0.025" mark; we have as a reading 2" + 0.3" + 0.025" or 2.325" plus the number of thousandths on the vernier scale. To determine this reading, begin at 0 on the scale, and move the eye carefully along till we find a line on the scale which coincides with a line on the beam, and the line on the scale gives us the number of thousandths to make up the total reading. We find that the present scale reading is twenty-two, and thus we have:

$$2'' + 0.300'' + 0.025'' + 0.022'' = 2.347''$$

as the setting of the instrument. To set the vernier at any given reading, place the 0 mark on the vernier scale to the nearest 0.025" division possible, and add the required number of thousandths to this setting, by using the vernier. The learner should practice a number of

different settings of the instrument, in order that he may become proficient in using this type of caliper.

The Angular Vernier Scale. — In the use of this scale it is desired to obtain small fractional readings of parts of the degree; commonly this is five minutes (indicated 5'). This is equal to $\frac{1}{12}$ of a degree. In laying down a scale of this sort the degree is the unit space on the beam. The fact that the beam takes a circular form does not in any way affect the process of working out the scale, except that we make calculations in fractions of degrees instead of fractions of inches. The division of the degree into parts, as we did the inch will produce too fine a scale to read, on instruments used in machine shop practice, so we use the whole degree, or two, three or four degrees, as the demands of practice may make necessary. If we use one degree, it is evident that the unit on the beam is divided into one part. Dividing 12, the denominator of the ultimate fraction by this, we find that we must have twelve divisions of the scale, and its length must be equal to eleven beam divisions, or eleven degrees. Now let us see if our reasoning will prove itself; beam divisions embraced by scale, 11 each 1° or $60'$. Scale divisions 12 each $\frac{1}{12}$ of 11° or $\frac{1}{12}$ of $660' = 55'$. So our scale division is 5' shorter than the beam division, which is the desired difference.

A scale twelve degrees long is too small for machine shop measuring instruments. The above calculations were carried out for illustrative purposes; the scale much used for angular work treats the beam unit as equal to one half a part; dividing twelve by one half

$\left(\frac{12}{\frac{1}{2}} = 12 \times 2 = 24\right)$ we find that our scale should contain

twenty-four divisions, and equal twenty-three degrees in length. Our calculations now work out as follows: beam

unit $\frac{1}{3}$ of $23^\circ = 60'$. Scale division $\frac{1}{4}$ of 23° or $\frac{1}{4}$ of $1380'$ or $57.5'$, giving us a measurement of $2\frac{1}{4}'$. Five minutes is sufficiently accurate for most work, so we place a graduation at every second place on the scale, giving us a twelve space scale, and our scale division length becomes $\frac{1}{2}$ of $1380'$ or $115'$, and each scale division then spans two beam divisions, with a difference between scale and beam division of five minutes.

In connection with the study of the vernier, the learner will notice that the scale division is always the smaller, and that the increment of measure is obtained by moving the scale division into line with the beam division.

Reading the Angular Vernier. — The 0 mark on the scale is the point to be observed in making all readings. The number of degrees is read directly between the 0 on the beam and on the vernier scale.

The number of minutes is determined by carefully looking along the vernier scale in the same direction in which the whole degrees have been read. The first coinciding line between lines on scale

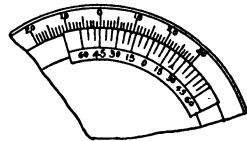

Fig. 198

and on beam, gives the number of minutes. The number of divisions thus counted on the vernier scale should be multiplied by five, to determine the number of minutes. The angular vernier may be read in either direction from the 0 line of the beam divisions. Look at the reading shown in Fig. 198; the 0 of the vernier is sixteen degrees from 0 of the beam divisions, and we see that the fifth division from the vernier 0, is the first division in line with a beam division. The reading then is $16^\circ 25'$. All readings in this case were in a clockwise direction from the 0 line of the beam.

In many places in this text, the learner has seen the term "surface speed" used, and the meaning of the term

has been explained. It is important on certain occasions, that the surface speed be calculated. To determine the surface speed of a revolving piece we first determine the number of revolutions per minute that the work is making. This is obtained by counting, or by using a speed indicator; (see small tool catalog for a description of this instrument). After finding the number of revolutions per minute which the work is making, the circumference must be determined. This value multiplied by the number of rev. per min. will give us the number of inches per minute the work is running, assuming that the circumference was calculated in inches, which is usually the case. The result must be divided by twelve, to determine the feet per min. In shop practice, "rev. per min." is usually represented by R. P. M. and "feet per min. by Ft. P. M. From the above we may form a simple rule as follows:

The cutting speed in Ft. P. M. is equal to the circumference of the work in inches, multiplied by the R. P. M. of the work, and this product divided by twelve.

This may be worked into a formula as follows:

Let S = Surface speed Ft. P. M.

C = Circumference of work in inches — equals
 $3.1416 D$ (D = Diam. of work in ins.).

R. P. M. = Rev. per min.

12 = Number of inches in one foot.

Then

$$S = \frac{3.1416 D \text{ times R. P. M.}}{12}$$

This method of calculation may be used for any revolving piece of work or tool. To determine the cutting speed of a shaper or planer, set the stroke so the ram or table will

run a length of two feet. Start the machine and holding a watch in hand, read the number of seconds it takes to make this stroke.

The number of seconds in a minute, sixty, divided by the number of seconds just found will give us the multiple of two feet which is to be used in calculating the cutting speed in Ft. P. M. The following rule may be evolved: Find number of seconds it takes planer to travel 2 ft.; divide 60 by this number and multiply the quotient by 2; the result will be cutting speed in Ft. P. M.

The following formula is derived.

S = Cutting speed Ft. P. M.

T = Time in seconds for table to travel 2 ft.

60 = Number seconds in one min.

2 = Number of feet in unit of travel.

$$S = \frac{60}{T} \text{ times } 2$$

Any other number of feet than two, may be used as a unit of travel, provided due allowance is made for such a unit, in other calculations. There is an instrument on the market, known as a "cut meter" which may be placed against a piece of revolving or reciprocating work, and the cutting speed in feet per minute read directly from a dial. This is a very convenient tool for shop use.

Calculation of Pulley and Gear Speeds. — There are a great many occasions on which the machinist must calculate the relative number of revolutions of pulleys and gears which run in various combinations. The law of ratio is the foundation of all of these calculations. A *ratio* is the relation of one number to another, as found by dividing one by the other. As an example 2 to 4 or 2:4 or $\frac{2}{4} = \frac{1}{2}$ indicates the ratio of the first to the second number. A *proportion* indicates an equality of two ratios; as an ex-

260 PRACTICAL MACHINE SHOP PRACTICE

ample $\frac{3}{8} = \frac{4}{8}$ or $3:6::4:8$. This simple mathematical arrangement is very useful to the mechanic. The first and last figures in a proportion are known as the **extremes**, while the second and third figures are called the

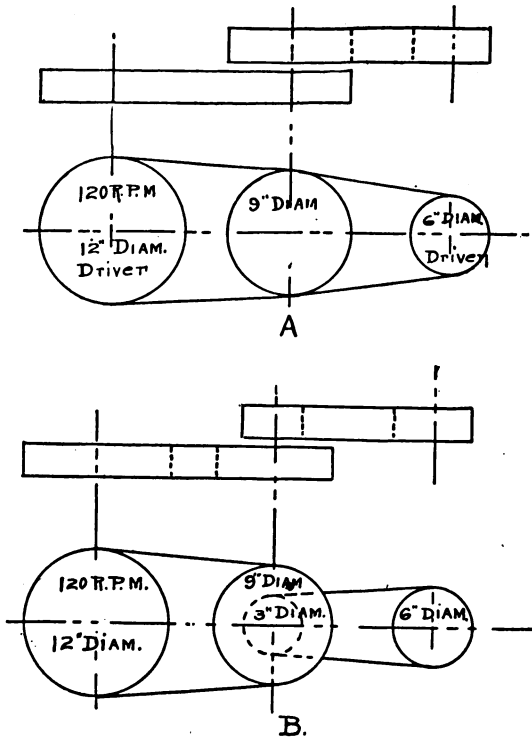

Fig. 199

means. If we multiply the **extremes** together, we will find that the product equals the product of the **means**. It is evident that if we have given any three terms of a proportion, we can easily obtain the fourth. For a number of machine shop calculations, we find that the inver-

sion of one of the ratios of a proportion gives us the desired result; the various elements are then spoken of as being **inversely proportional**. We will meet a practical application of this truth when we take up the calculation of the speeds of pulleys in detail.

In any arrangement of pulleys on gears, the first element of a train is known as the "**driver**," and the element receiving power from this driver is known as the "**driven**" element. Elements placed between the driver and the driven unit, are known as "**intermediates**"; they may or may not affect the speed ratio of the main elements, depending on the arrangement of the intermediate elements, as will be seen later. Looking at Fig. 199 A we see an arrangement of pulleys and belts, in which the belt from the driver transmits power to an intermediate, and this in turn transmits power to the driven element. Now it is a proven law of kinematics that **the speeds of two pulleys are inversely proportional to their diameters**. In the present problem, the driver is 12" diam. and runs 120 R. P. M. It is evident that the intermediate speed can be determined by the following inverse proportion:

12: 9:: Speed of int.: 120 or 160 R. P. M.

Applying the law again and treating the intermediate as the driver we will have for the speed of the driven pulley:

9: 6:: Speed of driven: 160 or speed of driven is 240 R. P. M.

Now let us neglect the intermediate entirely and work our inverse ratio directly from first driver to last driven and our proportion becomes

12: 6:: Speed of driven: 120 or speed of driven is 240 R. P. M. From this it is evident that our intermediate has no effect on the relation of speeds, of first driver and last driven, if the two pulleys or gears on the intermediate

shaft are the same size. This is a fact, and whenever we have a series of intermediates of the same size, regardless of their number, in a train of belting or gears we may neglect them in our speed calculations. Their only effect is to make a difference in the direction of rotation, in the case of gearing. They may be totally disregarded in belting problems, so far as speed is concerned.

Now let us give our attention to Fig. 199 *B* where we have a different intermediate, using two sizes of pulleys. Driver and first driven same size; as in former problems driver 120 R. P. M.

$$12:9::x:120. \quad x = 160.$$

x = R. P. M. of intermediate shaft.

Now applying our proportion again using the intermediate as driver, and noticing that we are running our belt from a 3" pulley on the intermediate to a 6" pulley on the driven, we have:

$3:6::x:160 = 80$ R. P. M. for last driven. It is very evident that any change in size of pulleys or gears used on an intermediate element, will make a difference in the speed obtained between the first driver and last driven element.

In making calculations dealing with pulleys and gears, it is customary to regard any element which supplies power to another element, as a driver, and any element receiving power, as a driven element, regardless of its position in the train. This will make every "intermediate" a driven element, when considered relative to the unit from which it receives power, and a driving element relative to the unit to which it delivers power. Studying the problem presented in Fig. 199 *B* we notice that the ultimate ratio of speeds from first driver to last

driven is $\frac{120}{80}$. In view of the explanations just made

concerning the relation of driving and driven elements, we have drivers 12" and 3" diameter and driven elements 9" and 6" diameter. The relation of all drivers to all driven elements is

$$\frac{12 \times 3}{9 \times 6} = \frac{36}{54} = \frac{2}{3}$$

From these calculations it is evident that **the product of the diameters of all drivers, divided by the product of the diameters of all driven units, will give us the final ratio of any train of belt or gearing.** Furthermore the speeds of first driver and last driven unit of a train are inversely proportional to the final ratio of the train.

By way of proof of this last statement let us analyze the train shown at Fig. 199 B. The first driver runs 120 R. P. M.; what will be speed of last driven unit? The driver and driven ratio is

$$(12 \times 3) : (9 \times 6);$$

our proportion becomes

$(12 \times 3) : (9 \times 6) ::$ speed of last driven: 120 or speed of last driven unit is 80 R. P. M. This is the same result as obtained by separate calculation. The above explanations make comparatively simple the various calculations of speeds as applied to pulleys and gears. In the case of gears, the **pitch diameter** should be used in all calculations of speed, when the diameter is introduced in the work. The number of teeth in a gear may be introduced in the place of the diameter, and the same results will be obtained, so far as speed calculations are concerned.

Calculating Gears for Cutting Threads on the Engine Lathe. — In earlier chapters, directions have been given for cutting threads on the lathe. The type of machine studied was equipped with a quick change gear system, but the learner will recall that mention was made of the

fact that all machines are not so equipped. The smaller tools used for general jobbing work are designed so that the change gears are shifted by removal from various shafts, and other gears substituted when a change is made. At Fig. 200 is shown an end view of a lathe, equipped with removable change gears. Each of the elements with

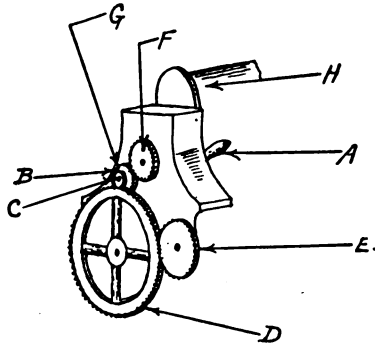

Fig. 200

- A. Reversing lever for tumbler gears.
- B. First gear on stud compound.
- C. Second gear on stud compound.
- D. Intermediate or swing plate gear.
- E. Screw gear or driven gear.
- F. Driving gear or stud gear.
- G. Compound element; composed of two gears mounted on and keyed to a bushing which in turn is mounted on a stud carried on a swinging arm.
- H. Section of lathe cone pulley.

which we will deal in our calculations is marked. Notice the intermediate countershaft, sometimes spoken of as a "compound." This is not used in cutting all threads; if it is swung out of the way, so that the stud gear *F* meshes directly with the intermediate swinging gear *D*, we will have to deal with but two gears in our calculations, the stud gear and lead screw gear, as it is evident from our previous analysis of gear trains, that it will have no effect

on the speed relations of these gears. We will study calculations with and without the use of the intermediate countershaft.

A number of gears are furnished with lathes of the class we are now studying; these gears are necessary in cutting the various threads met in machine shop practice. If the gears are examined it will be found that the number of teeth in successive gears increases in regular order. This increase in the number of teeth for each gear, is known as the **progression** of the set. Commonly the first gear of a set is 24, next 28, then 32, 36, 40, 44, 48 and so on, four teeth being added to the number of teeth in each gear, to determine the number of teeth in the next gear of the set. It is evident that the progression here is four. The first step in calculating gears for thread cutting, is to determine the progression of the set of gears furnished with the lathe. The next step is to determine the number of threads per inch on the lead screw. This is measured with a steel rule as previously described; we will assume that it is six. Now the size of the gears to be used in cutting the thread will depend on the ratio of the threads per inch on the screw to be cut, to the threads per inch on the lead screw. This will be evident if one studies the construction of the lathe in Fig. 200, where it is seen that the spindle drives the stud gear *F*, and this in turn drives the lead screw gear *E*. At *A* in this figure is seen a reverse gear lever; the use of these gears has been explained. In making calculations for thread cutting gears, the workman should always be sure that one revolution of the lathe spindle produces one revolution of the stud gear. Commonly it does, but occasionally it does not, and if it does not, the number of teeth in the driver, as found in the following work, should be divided by the number of turns the stud gear makes to one turn of the spindle, to determine the correct

number of teeth in the stud gear. This point will be illustrated in the calculations.

As an illustrative problem let us calculate the gears necessary to cut eight threads per inch, on a lathe having a lead screw of six threads per inch, and a direct transmission through the head; that is stud gear makes one turn when spindle makes one turn. The gears are determined by an inverse ratio of the number of threads per inch to be cut, and number of threads per inch on the lead screw. We wish to cut 8 threads per inch. We have on lead screw 6 threads per inch. The ratio of driver to driven gear is then 6 to 8, since our gears are an inverse ratio of the threads. We could use any gear we chose as a driver, and accommodate our driven gear to it, but from the standpoint of practice it will be wise to use those gears furnished with the lathe. If we multiply our ratio as found above by the progression of the set of gears we are using, we are sure to select a gear which is supplied with the machine. Our progression was four, so multiplying 6 and 8 our ratio units by 4, we have a 24 tooth gear for the driver, and a 32 tooth gear for the driven gear. Hence the following convenient rule. **To find proper gears to cut a thread, multiply threads per inch on lead screw by the progression of gear set, to determine driver, and threads per inch to be cut, by progression to determine driven gear.**

Suppose that the stud gear makes but one half turn for each turn of the spindle; we then divide 24, the number of teeth found for the driver with a direct transmission by $\frac{1}{2}$, and we must use a 48 tooth gear as a driver, instead of a 24 tooth gear.

In the above problem, it was not necessary to use the intermediate countershaft or compound. Suppose we have to cut a thread which shall have but three fourths of a turn to the inch, instead of eight threads; that is, the

lead is $1\frac{1}{3}$ " instead of $\frac{1}{8}$ ". A little thought will show that the lead screw must revolve quite rapidly, relative to the spindle, in order to carry the tool fast enough to cut this thread. The ratio of the threads per inch to be cut,

and the threads per inch on the lead screw is $\frac{3}{6}$ and the

ratio of driving to driven gears is $\frac{6}{3}$ or $\frac{6 \times 4}{3} = \frac{24}{3}$. If we

multiply this by the progression we will require gears $\frac{96 \text{ teeth}}{12 \text{ teeth}}$; but the smallest gear we have in our set is a

24 tooth gear. In order to bring our ratio into the range of our gear set we must double each element and the gears required are $\frac{192}{24}$ teeth. We cannot place a 192

tooth gear on the lathe, so it is impossible to cut the thread we have under consideration, if we use but one driver and one driven gear in our train. It is possible to cut this thread with our present gear equipment, if we employ the intermediate countershaft or compound. Returning to our earlier calculations, we see that the ultimate ratio of our driving to driven gears must be $\frac{24}{3}$.

We recall that the ultimate ratio of any train of gears is equal to the product of the number of teeth in the drivers, divided by product of the teeth in the driven gears. Looking at the construction of the intermediate countershaft we see that it is possible to mount two gears here, one of which will be a driven gear from stud gear, indicated at *B*, and the other a driving gear to gear on swing plate. This is indicated at *C*. We must have our gear ratio in such a form that we can factor both elements, and

the denominator 3 in the above ratio is not factorable. We may multiply both terms of this ratio by the same number without affecting its value, however, and by so doing, get both elements in factorable form. We will multiply by 2, and our ratio is $\frac{48}{6}$. We might multiply

by any other number, but in making such transformations as we are discussing, it is best to keep the numbers involved as small as is consistent with the result we wish to attain. Using our ratio in the form of $\frac{48}{6}$ we find that

it conveniently factors to $\frac{8 \times 6}{3 \times 2}$; the 8×6 combination

represents the driving gears and the 3×2 combination the driven gears of our train. We may now multiply these units by our progression or any multiple of it, and obtain gears which may be used. We cannot use a gear of less than 24 teeth, because we do not have one in our set. Inspecting the ratio combination which we have developed, we find that we must multiply all elements by 12, in order that no required gear shall have less than 24 teeth. Following this suggestion we must use driving gears of 96 and 72 with driven gears of 36 and 24. The arrangement which this train will take on the machine will be a 96 tooth gear for a stud gear, meshing into a 36-tooth gear as indicated at *B*, Fig. 200, with a 72 tooth gear mounted in position indicated at *C*, meshing into the swing gear, and a 24 tooth gear on the lead screw at *E*.

In working out gearing for such work as illustrated, a great many combinations are available. The illustrations serve to show the principles involved in the calculations, however; occasionally one meets a combination demanding a gear not available from the change gear set, regard-

less of the variations made in calculations. Under such circumstances it is necessary to turn and cut a gear of the proper size.

Calculations Used in Connection with Simple Indexing on the Miller. — Before starting this study, a brief analysis of Fig. 201 will be helpful. This is a diagram of the arrangement of the parts of a milling machine dividing head, which are necessary for the various indexing

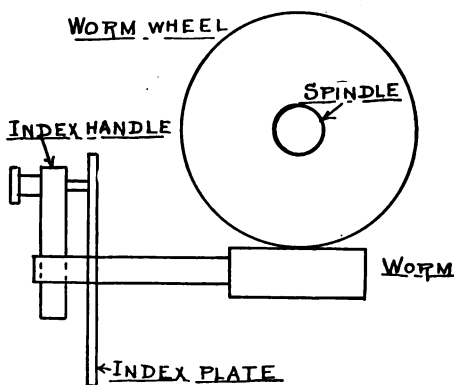

Fig. 201

movements. If the learner will carefully mark a point on the spindle of a miller dividing head, and turn the index crank till the spindle has made a complete revolution, he will find that in most machines, the index crank will have made 40 turns. This is not always true but it holds for most miller designs. The first step in making indexing calculations, is to find out how many turns of the index crank are necessary for one complete turn of the spindle. The next step is to inspect the index plates, and find out the range of index circles available. These plates are made up with several circles on each plate, and each circle is laid out in a series of holes, so that we may obtain fractional parts of the turns of index handles.

The index circles listed by one manufacturer are as follows:

Plate #1 — 15, 16, 17, 18, 19, 20

“ #2 — 21, 23, 27, 29, 31, 33

“ #3 — 37, 39, 41, 43, 47, 49

Thus we have three index plates available on this machine, each plate having six index circles, each circle being drilled to the number of holes indicated. The number of holes in a circle, will be seen stamped on the plate, in the line of the circle. Let us assume that forty turns of the index handle, turns the machine spindle once; it is evident that each turn of the index handle turns the spindle $\frac{1}{40}$ th of a turn. Now the feature to be determined in an indexing calculation, is the number of turns of index handle to produce the required movement of the spindle. If we were to cut forty divisions then we would move one turn of the handle for each tooth; if there are more than forty divisions the index handle will move less than a complete turn, and if less than forty, the handle moves more than one turn; a little study will make this point evident. In other words, the movement of the index handle, is an inverse ratio to the number of divisions wanted in a circumference. Since one turn of the handle gives us 40 divisions the ratio of divisions to index handle movement is 40 to 1. It might be any other number, and our process of calculation would be the same. As our index handle movement is in inverse ratio to the number of divisions wanted, the following proportion will solve our problem for any division.

40 : Number of div. wanted :: required turns : 1. Suppose, for illustration that we want three divisions, then our calculation becomes

40 : 3 :: turns : 1 = $13\frac{1}{3}$ turns of index handle. Now in setting up, we must select an index plate which will permit $\frac{1}{3}$ of a turn of the index handle. This may be ob-

tained by using five spaces on fifteen circles, six spaces on eighteen, eleven on thirty-three, or any other circle having a number of holes divisible by three.

If the proportion just given is studied, we will see that the number of turns of index handle was determined by dividing the total number of turns of the index handle, required for a complete turn of the spindle, by the number of divisions we wished to cut, and from this statement we may evolve the following rule:

To determine number of turns of index handle for a given number of divisions, divide number of turns of index handle for a complete revolution of the spindle, by number of divisions wanted.

Suppose we wish to cut fifty-five divisions we divide forty by fifty-five = $\frac{40}{55} = \frac{8}{11}$; so we may use twenty-four

spaces on the thirty-three hole, or $\frac{24}{33}$ of a turn of the

index handle. For the sake of practice the learner should calculate the necessary movement of index handle for a great many divisions, in order that he may become thoroughly familiar with the principles involved in the process of simple index calculation.

QUESTIONS

1. Describe the method of reading the vernier scale, as applied to linear measure.
2. As applied to angular measure.
3. Explain the method of calculating the surface speed of any revolving body.
4. A piece of work is 5.375" diam. and is running 93 R.P.M. What is its surface speed?
5. A grinding wheel is 22" diam. and runs 350 R.P.M. What is its surface speed?

272 PRACTICAL MACHINE SHOP PRACTICE

6. A piece of work is 3.250" diam. and is to run at a cutting speed of 90 ft. per min. How many R.P.M. must it make?

7. A grinding wheel is 15" diam. and is to run at a surface speed of 5000 ft. per min. How many R.P.M. must it make?

8. It is desired that the R.P.M. of two gears shall be as 3 to 4. Select two gears which will run in this ratio, and give the pitch diameters.

9. A shaft having on it a 6" pulley runs 250 R.P.M. We wish to drive another shaft 90 R.P.M. Give the diameter of pulley to be used on the second shaft.

10. We have available a 24" pulley to be used on a shaft that is to run 150 R.P.M. The driving shaft we must use runs 95 R.P.M. What diameter pulley must we use as a driver?

11. In a belting arrangement, from a driver to a driven shaft, it is necessary to use an intermediate counter shaft. The driving shaft runs 75 R.P.M. and we want to run the driven shaft 300 R.P.M. Select the pulleys, and illustrate the arrangement you will use.

12. A lead screw on a lathe is cut five threads per inch; the progression is four. What gears would you use to cut 10, $12\frac{1}{2}$, 16, and 24 threads respectively?

13. With a lead screw of five threads per inch, what gears would you use to cut three threads per inch? Progression of gear set four, and no gear less than 24 teeth.

14. With a lead screw of six threads per inch, progression 4, no gear smaller than 24 teeth, what gears would you use to cut $1\frac{1}{2}$ threads per inch?

15. Calculate the necessary index movement for obtaining the following divisions by simple indexing. Give all index circles which could be used, and the necessary fractional division in each case: 12, 15, 22, 30, 33, 50, 60, 85, 100. Assume that you have the same range of plates as mentioned in the text, in connection with simple indexing.

CHAPTER XV

MACHINE GLOSSARY

THIS glossary is introduced for the purpose of assisting beginners in the machinist's trade, to an understanding of the many technical terms met in every day practice. Terms which are clearly defined in the text, in a way that will fix them in the learner's mind, are not introduced a second time in this glossary.

Apron: any overhanging shield, covering the face of a machine part. It often carries some actuating mechanism, as the apron of a lathe carries much of the feeding mechanism.

Arbor: any element used to carry a revolving cutting tool, as milling machine arbor.

Backrest: a device used on the engine lathe for the purpose of supporting long work during the turning operation. It is attached to the carriage and supports the work near the cutting tool; it should not be confused with the steady rest.

Breast drill: a small drill worked by hand, and fed by means of the pressure exerted on the head, as it rests against the workman's chest. It is not used for drills over $\frac{1}{4}$ " or $\frac{5}{16}$ " diameter, as a rule.

Bushing: an element which serves as a lining, between a journal, and the inner wall of a bearing. When worn out, the bushing may be removed and a new one inserted, while the main parts are still serviceable. The bushing is usually though not always, of some softer material than the journal.

Backlash: the loose play between various parts of a machine; a certain amount is unavoidable in order that

the machine may operate, but it should be as little as is consistent with working.

Bull wheel: the main driving gear in any heavy gear train; it is seen in the platen driving train, inside the planer bed.

Back gears: any set of gears arranged in relation to the main driving element of a machine so that the speed may be reduced by introducing them; these gears are used on all lathes, drill presses, except sensitive drills, and many other machines.

Bed: the main casting of a machine; it is the principal supporting element.

Coloring acid: a mixture of blue vitriol, water and sulphuric acid, which is rubbed over finished surfaces with waste or a piece of cloth, to color them so that layout lines may be easily seen. The following is a satisfactory mixture:

$\frac{1}{4}$ pint of water
 $\frac{1}{4}$ oz. of sulphate of copper
 50 drops sulphuric acid.

The sulphate of copper should be dissolved in the water, then the acid added a few drops at a time, shaking the solution well at each addition. The solution is often made up without the acid, and gives good service. If acid is used keep solution away from hands and face at all times. Blue vitriol is often spoken of as "copperas" in the shop.

Cutting compound: or cutting solution; any solution used to lubricate cutting tools or grinding wheels, during the cutting operation; the following has proven very satisfactory:

Eight parts of washing soda, dissolved in 15 parts of boiling water; add to this one part of lard or sperm oil. Let solution cool before using. There are a number of prepared cutting solutions sold by supply dealers.

Cross feed handle: any handle controlling a cross feed on a machine.

Cross feed knob: any knob controlling the automatic cross feed of a machine.

Carriage: the part of a machine, with all its actuating mechanism which supports a movable cutting tool; the carriage of a lathe.

Centers: the elements which support any revolving piece of work, by means of holes or points formed in, or on the ends of the work; lathe centers.

Cross-rail: the horizontal rail on a shaper or planer, on which the knee or head apron slides.

Compound rest: a tool rest so designed that the tool may be made to travel at any angle to the center line of the machine, that the work may demand. The compound rest is most commonly applied to the engine lathe.

Column: the main upright element on a vertical machine, to which the secondary parts are attached. It corresponds in the upright machine, to the bed in a horizontal machine; the column of a miller, or of a drill press.

Cross-slide: any sliding element which may be moved across the base casting; cross slide of a miller, or slotter.

Cam: a mechanical element designed with an irregular face or periphery so as to produce some desired motion; slotter feed cam.

Clutch: a releasing device designed with engaging teeth, which may be placed in fast position with a driving half, or released at will; the disengaging half is usually keyed to the shaft it is to drive, and slides on it lengthwise. Friction clutch; see under friction.

Cat-head: a plate or block, having several set screws projecting radially from the center, which is placed inside a piece of pipe or other hollow element, in order to support the work on lathe centers during a turning operation.

Dutchman: a small piece of material dovetailed into the body of casting, or forging, for the purpose of remedying some defect.

Drunken thread: a crooked thread caused by the springing of the cutting tool, or some other defect in the machine, which produces a thread of irregular lead.

Dividing head: any type of headstock which is used primarily to divide a circle into any given number of parts; the miller dividing head. Sometimes spoken of as the index head.

Dog: a contrivance used to drive work in the lathe, grinder, or other machine; sometimes called carriers. Also any small piece so placed on a machine that it trips a feed or reversing mechanism; the miller feed trip dogs; planer reversing dogs. The term is applied to a great many small holding, and striking devices.

Elevating screw: any screw used to raise or lower a machine part; cross rail elevating screws on planer; knee elevating screw on miller.

Follow rest: see backrest.

Feed rack: any rack which acts as part of the feeding mechanism of a machine. See also Rack.

Friction disk: a specially designed disk for carrying a machine part to a certain position, and permitting it to stop at some predetermined point, while the driving element continues to revolve; feed friction disk on the planer.

Friction clutch: any clutch in which the power is transmitted from one element of the clutch to the other, by means of surfaces held in frictional contact, instead of by means of teeth in the clutch; cone friction clutch in overhead works of lathe. See Overhead Works.

Feed rod: any rod carrying a worm or other device which moves a tool carrying part; lathe feed rod.

Feed screw: a screw serving the same purpose as a feed rod. Some lathes use the lead screw as a feed screw;

but this is a poor practice, if the screw is depended upon to cut accurate threads, as the constant service of the screw wears it out of truth.

Foot stock: any part of a machine which acts as a supporting element, for work driven at one end, and which must be sustained in a given position at the other end; it contains no driving mechanism, as a rule. Its purpose is to properly support one end of the work; lathe footstock; grinder footstock.

Footstock cap: see poppet head.

Feed handles and knobs: the various handles and knobs that control the feeds; they are designated by the feed they control, as the horizontal feed handle, transverse or crosswise feed handle, etc.

Guides: the various elements of a machine which serve to keep sliding parts in their proper position during movement; lathe guides, planer platen guides. See Ways.

Gib: an element placed between sliding surfaces for the purpose of taking up wear.

Head: any main part of a machine; commonly though not always it carries the driving elements; lathe head; planer head.

Headstock: that portion of a rotating machine which carries the driving mechanism; lathe headstock.

Intermediate gear: any gear or gears of a train between the first driver, and last driven gear of the train.

Journal: that part of a shaft which runs in a bearing.

Jack: a device for lifting heavy parts, by applying beneath the load. It may be hydraulic or screw type.

Knobs: are the various knurled, and irregularly shaped pieces, found at various points about a machine, which are used to throw into and out of action the various feeds. The throwing is effected by pushing, pulling or turning the knob.

Knee: an element of right angular form, used as a support for working parts of a machine; it may be movable or stationary; miller knee; shaper knee.

Lead screw: the screw which moves the carriage of a lathe during the thread cutting operation.

Lead screw nut: the nut which is thrown into engagement with the lead screw when it is desired to connect the carriage to the lead screw.

Longitudinal or length feed handle: the handle which enables the operator to make any lengthwise feeding movement of a machine part.

Lock nut: lock pin; the nut or pin which is slacked off, or thrown out of engagement, when one wishes to disengage the cone pulley, in order to throw in the back gears. Term is often used to imply same meaning as term check nut. See body of text for check nut.

Miter gears: a pair of bevel gears of equal size, connecting shafts at right angles.

Monitor; see turret.

Old man: any device used to clamp a portable machine in place; it may be a set of chains and a brace, or a set of clamps and a brace. See body of text in connection with use of ratchet.

Over-hang arm: any arm which extends out from the main body of a machine, to support another part; miller over-hang arm.

Outboard bearing: a bearing located outside the main body of a machine, for the purpose of supporting an extending shaft; steam engine outboard bearing.

Overhead works: the pulleys and shafting suspended from the ceiling, which are necessary to transmit the power from the main shaft to the machine.

Pinion: the small gear of a train; it is usually the first driver.

Poppet head: also spoken of as footstock cap; the upper part of a footstock which may be moved crosswise relative to the length of the machine.

Platen: also spoken of as table; a flat surface element on any machine, which is used as a support for work; usually designed with some kind of machinery attached for making necessary movements.

Pawl and ratchet: a toothed wheel (the ratchet), arranged in relation to a latch (the pawl), in such a way that a backward and forward movement of the pawl, shall produce only a forward movement of the ratchet. The pawl may be thrown out of action at the will of the workman, or it may, in some designs be reversed, producing only a backward movement. This device is much used on shapers, planers, and on the hand ratchet.

Pulley tap: a long tap so made that it will pass through the rim of a pulley, and tap a hole in the hub.

Quick return: any device which quickly returns a machine part from a final to a first position; introduced on shapers, planers, millers and drillers; the detail of design varies greatly in form.

Ratchet: see pawl.

Rack: a straight, linear element with gear teeth on the face; lathe feed rack; planer platen rack.

Riser block: any block or device used to raise some part from the machine table or bed, in order to accommodate larger work, or to make special settings; milling machine riser block.

Ram: the reciprocating element of any planer type of machine, in which the tool is carried over the work, rather than the work under the tool; shaper ram; slotter ram.

Saddle: any element which acts as a supporting member for parts to be carried over, or along another part of a machine; the saddle carries other operating parts of the machine; saddle of the lathe carriage.

Slide block, or tool block; the block which supports the tool post on a machine; lathe slide block.

Shaft: any revolving element which is considerably greater in length than in diameter; it usually carries pulleys or gears.

Sizing: the final bringing of work to the finished dimensions.

Sizing machine tools: giving the specific dimensions by which the various tools are classified; for the tools mentioned in the present text these are as follows:

Engine Lathes: in the American market are classified by the diameter of work which can be swung over the bed; in the English market by the distance from the center to the top plane of the bed.

Planers: by the length, width and height which the machine will plane; sometimes listed by length or width only, when placing in shop lists.

Shapers: by the length of stroke.

Slotters: by the length of stroke.

Milling machines: by the table movements; lengthwise, cross wise and vertical, named in the order here given.

Upright drills: by the diameter of work which the table will carry, assuming that the work is circular; it is actually twice the distance from the center of the spindle to the column.

Universal grinding machines: by the diameter and length of work that can be accommodated between centers.

Polishing heads: distance from base to the center of spindle.

Arbor presses: distance from plate to extreme upper position of plunger.

Vises: width of jaw.

Step bearing: a vertical bearing which supports the weight, brought on a shaft, by a bearing at the end,

rather than by circumferencial support alone; nearly all vertical shafts in a machine are supported by some form of step bearing.

Steady rest: a stationary device, clamped to the ways of a machine, for the purpose of supporting a long bar, during turning or boring operations; lathe steady rest.

Scarfig: setting a cutting tool so that it takes a dragging chip when passing over the surface; the tool is set so that its side cutting face is at an angle other than 90° with the center line of the work.

Slide: any element so designed that it can be moved to and fro on a base, by means of ways and guides; the planer head slide.

Swing plate: any plate which may be swung to various positions about a center; it often carries adjustable gears; lathe swing plate.

Spindle: the smaller central element of a machine part which acts as a sort of shaft on which other parts are located, and by means of which motion is transmitted.

Shipper: a device for starting and stopping a machine, by means of throwing a belt, from a tight to a loose pulley, or by throwing a clutch into or out of engagement.

Tumbler gears: any pair of gears, set in a rocking bracket, in such a manner that first one, then another gear, may be brought into mesh with a driving gear; lathe tumbler gears.

Tool post: tool clamps; the elements which hold the cutting tool in place when a machine is in operation.

Turret or monitor: a revolving element which carries several cutting tools, which may be successively brought into line for cutting operations; the turret lathe.

Table: see platen.

Upright: any vertical sustaining element of a machine; planer uprights.

282 PRACTICAL MACHINE SHOP PRACTICE

Verticle feed handles: the handles, or knobs that control the vertical feed; see knobs.

Vise or shoe: the device used to hold work for taking a surface cut on planer, shaper or miller.

Worm: a short screw, usually of special form of thread, running in mesh with a worm wheel; lathe feed rod worm; miller dividing head worm.

Ways: the elements which serve as a seat for the guides on various machine parts; the planer platen ways.

TABLES

TABLE I. — STEEL RULE GRADUATIONS AS LISTED BY THE
BROWN AND SHARPE MFG. CO.

#1 Graduation.

1st Edge,	10ths, 20ths, 50ths, 100ths.
2nd "	12ths, 24ths, 48ths.
3rd "	14ths, 28ths.
4th "	16ths, 32nds, 64ths.

#2 Graduation.

1st Edge,	8ths.
2nd "	10ths, 20ths, 50ths, 100ths.
3rd "	12ths, 24ths, 48ths.
4th "	16ths, 32nds, 64ths.

#4 Graduation.

1st Edge,	8ths.
2nd "	16ths.
3rd "	32nds.
4th "	64ths.

The #4 graduation is the one most used by machinists.

284 PRACTICAL MACHINE SHOP PRACTICE

TABLE II. — SCREW THREADS, UNITED STATES STANDARD

Diameter of bolt	Set thread micrometer	No. of threads per inch	Hole in nut		
			Exact size	Approx. size	Tap drill size
$\frac{1}{4}$ inch	.2175	20	.1850	.188	$\frac{3}{16}$
$\frac{5}{16}$ "	.2764	18	.2403	.244	$\frac{1}{4}$
$\frac{3}{8}$ "	.3344	16	.2938	.298	$\frac{19}{64}$
$\frac{7}{16}$ "	.3911	14	.3447	.349	$\frac{23}{64}$
$\frac{1}{2}$ "	.4500	13	.4001	.405	$\frac{13}{32}$
$\frac{9}{16}$ "	.5083	12	.4542	.459	$\frac{15}{32}$
$\frac{5}{8}$ "	.5659	11	.5069	.512	$\frac{33}{64}$
$\frac{11}{16}$ "	.6284	11	.5694	.575	$\frac{37}{64}$
$\frac{3}{4}$ "	.6850	10	.6201	.626	$\frac{41}{64}$
$\frac{7}{8}$ "	.8028	9	.7306	.737	$\frac{47}{64}$
1 "	.9188	8	.8376	.844	$\frac{27}{32}$
$1\frac{1}{8}$ "	1.0322	7	.9394	.947	$\frac{31}{32}$
$1\frac{1}{4}$ "	1.1572	7	1.0644	1.072	$1\frac{3}{32}$
$1\frac{3}{8}$ "	1.2667	6	1.1585	1.167	$1\frac{3}{8}$
$1\frac{1}{2}$ "	1.3917	6	1.2835	1.292	$1\frac{5}{16}$
$1\frac{5}{8}$ "	1.5069	$5\frac{1}{2}$	1.3888	1.398	$1\frac{3}{32}$
$1\frac{3}{4}$ "	1.6201	5	1.4902	1.500	$1\frac{1}{2}$
$1\frac{7}{8}$ "	1.7451	5	1.6152	1.625	$1\frac{5}{8}$
2 "	1.8556	$4\frac{1}{2}$	1.7113	1.722	$1\frac{3}{4}$
$2\frac{1}{4}$ "	2.1056	$4\frac{1}{2}$	1.9613	1.972	2
$2\frac{1}{2}$ "	2.3376	4	2.1752	2.186	$2\frac{3}{8}$
$2\frac{3}{4}$ "	2.5876	4	2.4252	2.436	$2\frac{7}{8}$
3 "	2.8144	$3\frac{1}{2}$	2.6288	2.640	$2\frac{21}{32}$

TABLE III.—DIFFERENT STANDARDS FOR WIRE GAGES IN USE IN THE UNITED STATES
Dimensions of Sizes in Decimal Parts of an Inch

Number of Wire Gage	American, or Brown & Sharpe	Birmingham, or Stubbs' Iron Wire	Waaburn & Moen Mfg. Co., Worcester, Mass.	Imperial Wire Gage	Stubbs' Steel Wire	U. S. Standard Gages for Sheet and Plate Iron and Steel	Number of Wire Gage
00000046446875	000000
000004324375	00000
0000	.46	.454	.3938	.40040625	0000
000	.40964	.425	.3625	.372375	000
00	.3648	.38	.3310	.34834375	00
0	.32486	.34	.3065	.3243125	0
1	.2893	.3	.2830	.300	.227	.28125	1
2	.25763	.284	.2625	.276	.219	.265625	2
3	.22942	.259	.2437	.252	.212	.25	3
4	.20431	.238	.2253	.232	.207	.234375	4
5	.18194	.22	.2070	.212	.204	.21875	5
6	.16202	.203	.1920	.192	.201	.203125	6
7	.14428	.18	.1770	.176	.199	.1875	7
8	.12849	.165	.1620	.160	.197	.171875	8
9	.11443	.148	.1483	.144	.194	.15625	9
10	.10189	.134	.1350	.128	.191	.140625	10
11	.090742	.12	.1205	.116	.188	.125	11
12	.080808	.109	.1055	.104	.185	.109375	12
13	.071961	.095	.0915	.092	.182	.09375	13
14	.064084	.083	.0800	.080	.180	.078125	14
15	.057068	.072	.0720	.072	.178	.0703125	15
16	.05082	.065	.0625	.064	.175	.0625	16
17	.045257	.058	.0540	.056	.172	.05625	17
18	.040303	.049	.0475	.048	.168	.05	18
19	.03589	.042	.0410	.040	.164	.04375	19
20	.031961	.035	.0348	.036	.161	.0375	20
21	.028462	.032	.03175	.032	.157	.034375	21
22	.025347	.028	.0286	.028	.155	.03125	22
23	.022571	.025	.0258	.024	.153	.028125	23
24	.0201	.022	.0230	.022	.151	.025	24
25	.0179	.02	.0204	.020	.148	.021875	25
26	.01594	.018	.0181	.018	.146	.01875	26
27	.014195	.016	.0173	.0164	.143	.0171875	27
28	.012641	.014	.0162	.0149	.139	.015625	28
29	.011257	.013	.0150	.0136	.134	.0140625	29
30	.010025	.012	.0140	.0124	.127	.0125	30
31	.008928	.01	.0132	.0116	.120	.0109375	31
32	.00795	.009	.0128	.0108	.115	.01015625	32
33	.00708	.008	.0118	.0100	.112	.009375	33
34	.006304	.007	.0104	.0092	.110	.00859375	34
35	.005614	.005	.0095	.0084	.108	.0078125	35
36	.005	.004	.0090	.0076	.106	.00703125	36
37	.0044530068	.103	.00640625	37
38	.0039650060	.101	.00625	38
39	.0035310052	.099	39
40	.0031440048	.097	40

286 PRACTICAL MACHINE SHOP PRACTICE

TABLE IV. — SIZES OF WOODRUFF KEYS

The Woodruff key is semi-circular in form; the "length" in the table indicates the diameter of a circular blank from which the particular key designated could be made.

Length	Thickness	No. of key and cutter
$\frac{1}{2}$ "	$\frac{1}{16}$ "	1
$\frac{1}{2}$ "	$\frac{3}{32}$ "	2
$\frac{1}{2}$ "	$\frac{1}{8}$ "	3
$\frac{5}{8}$ "	$\frac{3}{32}$ "	4
$\frac{5}{8}$ "	$\frac{1}{8}$ "	5
$\frac{5}{8}$ "	$\frac{5}{32}$ "	6
$\frac{3}{4}$ "	$\frac{1}{8}$ "	7
$\frac{3}{4}$ "	$\frac{5}{32}$ "	8
$\frac{3}{4}$ "	$\frac{3}{16}$ "	9
$\frac{7}{8}$ "	$\frac{5}{32}$ "	10
$\frac{7}{8}$ "	$\frac{3}{16}$ "	11
$\frac{7}{8}$ "	$\frac{7}{32}$ "	12
1"	$\frac{3}{16}$ "	13
1"	$\frac{7}{32}$ "	14
1"	$\frac{1}{4}$ "	15
$1\frac{1}{8}$ "	$\frac{3}{16}$ "	16
$1\frac{1}{8}$ "	$\frac{7}{32}$ "	17
$1\frac{1}{8}$ "	$\frac{1}{4}$ "	18
$1\frac{1}{4}$ "	$\frac{3}{16}$ "	19
$1\frac{1}{4}$ "	$\frac{7}{32}$ "	20
$1\frac{1}{4}$ "	$\frac{1}{4}$ "	21
$1\frac{3}{8}$ "	$\frac{1}{4}$ "	22
$1\frac{3}{8}$ "	$\frac{5}{16}$ "	23
$1\frac{1}{2}$ "	$\frac{1}{4}$ "	24
$1\frac{1}{2}$ "	$\frac{5}{16}$ "	25

All keys, whether of Woodruff or square type should have a slight clearance between the top surface of the key and the bottom of the keyway formed in the hub.

TABLE V. — STANDARD SIZES OF SPRING COTTER PINS

Cotter pins are classified by their diameter, when tightly closed, and the length measured from the point to just below the eye.

Diameter	Lengths available
$\frac{3}{32}$ "	$\frac{1}{2}$ " — $\frac{3}{4}$ " — 1" — $1\frac{1}{4}$ "
$\frac{7}{64}$ "	$\frac{3}{4}$ " — 1" — $1\frac{1}{4}$ " — $1\frac{1}{2}$ "
$\frac{1}{8}$ "	$\frac{3}{4}$ " — 1" — $1\frac{1}{4}$ " — $1\frac{1}{2}$ "
$\frac{5}{32}$ "	$\frac{3}{4}$ " — 1" — $1\frac{1}{4}$ " — $1\frac{1}{2}$ "
$\frac{3}{16}$ "	1" — $1\frac{1}{4}$ " — $1\frac{1}{2}$ " — $1\frac{3}{4}$ " — 2" — $2\frac{1}{2}$ "
$\frac{7}{32}$ "	1" — $1\frac{1}{4}$ " — $1\frac{1}{2}$ " — 2"
$\frac{1}{4}$ "	$1\frac{1}{4}$ " — $1\frac{1}{2}$ " — $1\frac{3}{4}$ " — 2" — $2\frac{1}{2}$ "
$\frac{5}{16}$ "	$1\frac{1}{2}$ " — 2" — $2\frac{1}{2}$ " — 3"
$\frac{3}{8}$ "	$2\frac{1}{2}$ " — 3" — $3\frac{1}{2}$ " — 4"

TABLE VI. — SIZES OF MACHINE SCREWS, AND SIZES OF TAP DRILLS TO BE USED WHEN DRILLING AND TAPPING HOLES TO FIT VARIOUS SIZES OF SCREWS

Number of screw by gage	Diam. in thousandths of an inch	Number of threads per inch	Number of tap drill by drill gage. Diam. in thousandths of inch
2	.0842	56	#49— .073
3	.0973	48	#45— .082
4	.1105	36	#42— .093
5	.1236	36	#38— .101
6	.1368	32	#35— .110
7	.150	32	#30— .128
8	.163	32	#29— .136
9	.1763	30	#27— .144
10	.1894	24	#25— .149
11	.2026	24	#21— .159
12	.2158	24	#17— .173
13	.2289	22	#15— .180
14	.2421	20	#13— .185
15	.2552	20	#8— .199
16	.2684	18	#6— .204
17	.2816	18	#2— .213
18	.2947	18	#1— .228
19	.3079	18	C— .242
20	.321	16	D— .246

TABLE VI A

An effort is being made at the present time to introduce a more rational standard for machine screws than that presented in table VI. The screw is identified by the diameter in thousandths of an inch instead of by a number, and the variation in consecutive sizes is more logical. The following table is suggested by the American Society of Mechanical Engineers, but the use of this standard is not yet accepted in the hardware trade at large.

Diam. of screw	Threads per inch	Diam. of root of thread	
0.060	80	0.0438	Select tap drill from Table VII or VIII using a drill .003" larger than root diameter for small sizes, to .012" larger than root diam. for largest screw.
.073	72	.0550	
.086	64	.0657	
.099	56	.0758	
.112	48	.0849	
.125	44	.0955	
.138	40	.1055	
.151	36	.1149	
.164	36	.1279	
.177	32	.1364	
.190	30	.1467	
.216	28	.1696	
.242	24	.1879	
.268	22	.2090	
.294	20	.2290	
.320	20	.2550	
.346	18	.2738	
.372	16	.2908	
.398	16	.3168	
.424	14	.3312	
0.450	14	0.3572	

200 PRACTICAL MACHINE SHOP PRACTICE

TABLE VII. — DECIMAL EQUIVALENT OF VARIOUS NUMBERS OF THE TWIST DRILL GAGE

Number of drill	Diameter in thousandths of an inch	Number of drill	Diameter in thousandths of an inch
1	.228	31	.120
2	.221	32	.116
3	.213	33	.113
4	.209	34	.111
5	.205	35	.110
6	.204	36	.1065
7	.201	37	.104
8	.199	38	.1015
9	.196	39	.0995
10	.1935	40	.098
11	.191	41	.096
12	.189	42	.0935
13	.185	43	.089
14	.182	44	.086
15	.180	45	.082
16	.177	46	.081
17	.173	47	.0785
18	.1695	48	.076
19	.166	49	.073
20	.161	50	.070
21	.159	51	.067
22	.157	52	.063
23	.154	53	.0595
24	.152	54	.055
25	.149	55	.052
26	.147	56	.046
27	.144	57	.043
28	.140	58	.042
29	.136	59	.041
30	.1285	60	.040

TABLE VIII. — DECIMAL EQUIVALENTS OF LETTER SIZES OF DRILLS

Letter designating drill	Diameter in thousandths of an inch	Letter designating drill	Diameter in thousandths of an inch
A	.234	N	0.302
B	.238	O	.316
C	.242	P	.323
D	.246	Q	.332
E	.250	R	.339
F	.257	S	.348
G	.261	T	.358
H	.266	U	.368
I	.272	V	.377
J	.277	W	.386
K	.281	X	.397
L	.290	Y	.404
M	0.295	Z	0.413

TABLE IX. — CUTTING SPEEDS FOR COMMON REDUCTIONS
 F = Number of turns of cutter or work for 1 inch travel of table.
 S = Speed in feet per minute.

Operation	Formula	F=20 $\frac{1}{4}$ -inch reduction and average practice on light cuts	F=34.2 $\frac{1}{2}$ -inch reduction	F=58.48 $\frac{3}{4}$ -inch reduction	F=100 $1\frac{1}{2}$ -inch reduction	
Turning...	$S = -\frac{2}{3}F + 106$	93	83	67	39	Brass
Milling...	$S = -\frac{1}{2}F + 80$	69	62	50	30	
Drilling...	$S = -\frac{2}{3}F + 64$	56	50	40	24	
Planing...	$S = -\frac{1}{3}F + 53$	46	42	34	20	
Turning...	$S = -\frac{5}{12}F + 66$	58	52	42	25	Cast iron
Milling...	$S = -\frac{5}{18}F + 50$	43	39	31	18	
Drilling...	$S = -\frac{1}{2}F + 39$	35	31	25	15	
Planing...	$S = -\frac{5}{24}F + 33$	39	26	21	12	
Turning...	$S = -\frac{1}{3}F + 53$	46	42	34	20	Wrought iron and machinery steel
Milling...	$S = -\frac{1}{4}F + 40$	35	33	25	15	
Drilling...	$S = -\frac{1}{5}F + 32$	28	25	20	12	
Planing...	$S = -\frac{1}{6}F + 27$	23	21	17	10	
Turning...	$S = -\frac{5}{24}F + 33$	29	26	21	12	Tool steel
Milling...	$S = -\frac{5}{32}F + 25$	22	20	16	9	
Drilling...	$S = -\frac{1}{8}F + 20$	17	16	13	7	
Planing...	$S = -\frac{5}{48}F + 17$	14	13	10	6	

These rates are for carbon steel; for high speed steels these rates may be doubled in speed, keeping feeds the same as given.

TABLE IX A

C equals outside diameter of flange.
D equals thickness of flange at bore.
E equals diameter of recess on inner face of flange.

Diameter of wheel	<i>C</i> Inches	<i>D</i> Inches	<i>E</i> Inches
6"	2"	$\frac{3}{8}$ "	1"
8"	3"	$\frac{3}{8}$ "	2"
10"	$3\frac{1}{2}$ "	$\frac{3}{8}$ "	$2\frac{1}{4}$ "
12"	4"	$\frac{1}{2}$ "	$2\frac{3}{4}$ "
14"	$4\frac{1}{2}$ "	$\frac{1}{2}$ "	3"
16"	$5\frac{1}{2}$ "	$\frac{1}{2}$ "	$3\frac{1}{4}$ "
20"	7"	$\frac{5}{8}$ "	$4\frac{1}{2}$ "
24"	8"	$\frac{5}{8}$ "	$5\frac{1}{2}$ "

TABLE X. — ALLOWANCES FOR SHRINK, DRIVE AND RUNNING FITS

Nominal diameter of shaft	Drive fit. Shaft large	Shrink fit. Shaft large	Force fit. Shaft large	Running fit. Shaft small
1"	.001"	.0016"	.0021"	.002"
2"	.0015"	.0026"	.0031"	.003"
3"	.002"	.0036"	.0061"	.0035"
4"	.0024"	.0048"	.0083"	.0037"
5"	.003"	.0058"	.0102"	.004"
6"	.0035"	.0069"	.0124"	.004"
7"	.004"	.008"	.0144"	.004"
8"	.0045"	.009"	0.0164"	.0042"
9"	.005"	.010"		.0045"
10"	.0055"	.0112"	For sizes above	.005"
11"	.006"	.0122"	8" increase al-	.005"
12"	.0066"	.0136"	lowance 0.002"	.006"
13"	.007"	.0144"	for each inch	.006"
14"	.0076"	.0155"	increase in di-	.0062"
15"	.0086"	0.0176"	ameter of shaft	0.007"

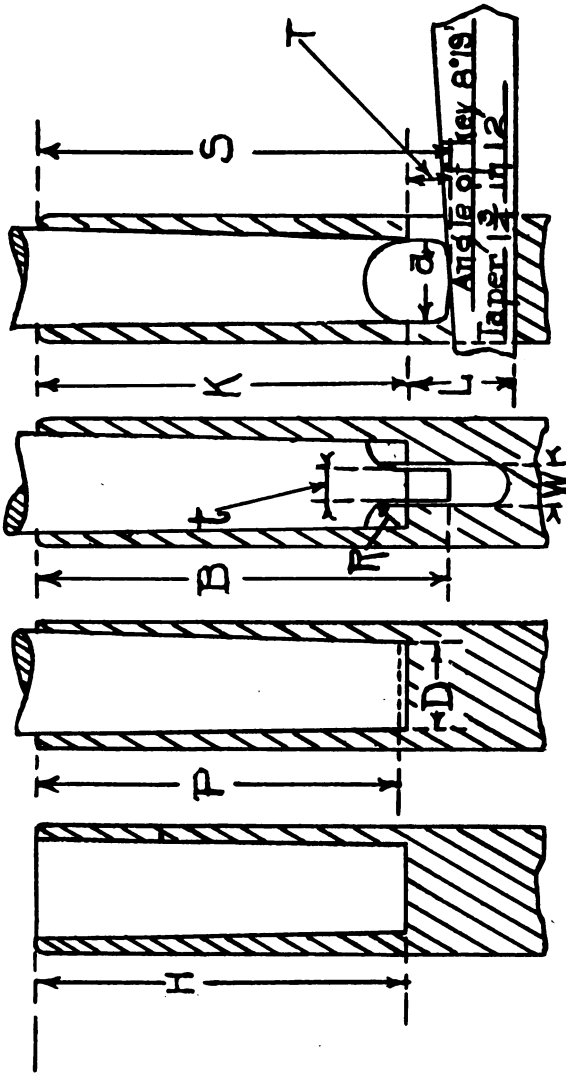

Properties of Morse Taper

TABLE XII. — PROPERTIES OF THE MORSE STANDARD TAPERS

Number of taper	Diameter of plug	Diameter at end of socket	Stand depth	Whole length of shank	Depth of hole	End of socket to keyway	Length of keyway	Width of keyway	Length of tongue	Diameter of tongue	Thickness of tongue	Radius of mill for tongue	Radius of tongue	Shank depth	Paper per ft.
0	1	2	3	4	5	6	7								
0	.252"	.356"	2"	2 $\frac{1}{8}$ "	2 $\frac{3}{8}$ "	1 $\frac{5}{8}$ "	1 $\frac{9}{8}$ "	.160"	1 $\frac{1}{4}$ "	.24"	5 $\frac{3}{8}$ "	5 $\frac{5}{8}$ "	.04"	2 $\frac{7}{8}$ "	.625"
1	.369"	.475"	2 $\frac{1}{8}$ "	2 $\frac{3}{8}$ "	2 $\frac{1}{8}$ "	2 $\frac{1}{8}$ "	2 $\frac{3}{4}$ "	.213"	1 $\frac{5}{8}$ "	.35"	1 $\frac{3}{8}$ "	1 $\frac{3}{8}$ "	.05"	2 $\frac{3}{8}$ "	.600"
2	.572"	.700"	2 $\frac{3}{8}$ "	3 $\frac{1}{8}$ "	2 $\frac{5}{8}$ "	2 $\frac{3}{8}$ "	7 $\frac{3}{8}$ "	.260"	1 $\frac{3}{8}$ "	1 $\frac{7}{8}$ "	1 $\frac{1}{4}$ "	1 $\frac{1}{4}$ "	.06"	2 $\frac{1}{8}$ "	.602"
3	.778"	.938"	3 $\frac{1}{8}$ "	3 $\frac{3}{4}$ "	3 $\frac{1}{4}$ "	3 $\frac{1}{8}$ "	1 $\frac{1}{8}$ "	.322"	1 $\frac{7}{8}$ "	1 $\frac{3}{4}$ "	1 $\frac{5}{8}$ "	1 $\frac{3}{8}$ "	.08"	3 $\frac{1}{8}$ "	.602"
4	1.020"	1.231"	4 $\frac{1}{8}$ "	4 $\frac{3}{4}$ "	4 $\frac{1}{8}$ "	3 $\frac{7}{8}$ "	1 $\frac{1}{4}$ "	.478"	1 $\frac{1}{2}$ "	1 $\frac{3}{2}$ "	1 $\frac{5}{8}$ "	1 $\frac{5}{8}$ "	.10"	4 $\frac{1}{2}$ "	.623"
5	1.475"	1.748"	5 $\frac{3}{8}$ "	6"	5 $\frac{1}{4}$ "	4 $\frac{5}{8}$ "	1 $\frac{1}{2}$ "	.635"	1 $\frac{5}{8}$ "	1 $\frac{3}{8}$ "	1 $\frac{3}{8}$ "	1 $\frac{3}{8}$ "	.12"	5 $\frac{3}{8}$ "	.630"
6	2.116"	2.494"	7 $\frac{1}{4}$ "	8 $\frac{5}{8}$ "	7 $\frac{3}{8}$ "	7"	1 $\frac{3}{4}$ "	.760"	2"	2"	2"	2"	.15"	8"	.626"
7	2.75"	3.27"	10"	11 $\frac{3}{8}$ "	10 $\frac{1}{8}$ "	9 $\frac{1}{2}$ "	2 $\frac{1}{8}$ "	1.135"	1 $\frac{3}{8}$ "	2 $\frac{1}{8}$ "	1 $\frac{1}{8}$ "	1 $\frac{1}{8}$ "	.18"	11 $\frac{1}{4}$ "	0.625"

The angle formed at the end of the tongue on a twist drill is 8° 19' or equal to a taper of 1 $\frac{1}{4}$ " per foot.

For the various diameters of drills the following numbers of tapers are commonly used in practice.

- #1 Taper for drills from $\frac{1}{8}$ " to $\frac{1}{2}$ " inclusive.
- #2 " " " $\frac{3}{8}$ " to $\frac{2}{3}$ " inclusive.
- #3 " " " $\frac{5}{8}$ " to $\frac{3}{4}$ " inclusive.
- #4 Taper for drills from 1 $\frac{1}{4}$ " to 2" inclusive.
- #5 " " " 2 $\frac{1}{4}$ " to 3" inclusive.
- #6 " " " 3 $\frac{1}{4}$ " to 4" inclusive.

In considering the length of a taper shank the length including the tongue is regarded as the dimension to be used.

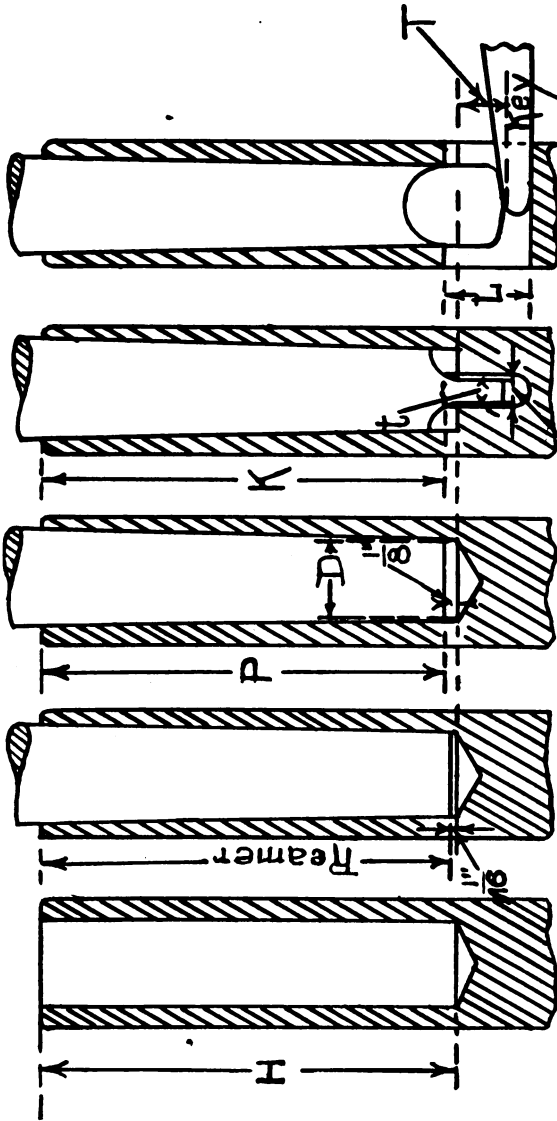

Properties of B. & S. Taper

TABLE XIII. — PROPERTIES OF THE BROWN & SHARPE
STANDARD TAPERS

Number of taper	Diameter of plug at small end	Plug depth	Depth of hole	Keyway from end of spindle or collet	Length of keyway	Width of keyway	Length of tongue	Thickness of tongue	Taper per foot
	<i>D</i>	<i>P</i>	<i>H</i>	<i>K</i>	<i>L</i>	<i>W</i>	<i>T</i>	<i>t</i>	
1	.20"	$\frac{15}{16}$ "	$1\frac{1}{16}$ "	$\frac{15}{16}$ "	$\frac{3}{8}$ "	.135"	$\frac{3}{16}$ "	$\frac{1}{8}$ "	.500"
2	.25"	$1\frac{3}{16}$ "	$1\frac{5}{16}$ "	$1\frac{11}{16}$ "	$\frac{1}{2}$ "	.166"	$\frac{1}{4}$ "	$\frac{5}{32}$ "	.500"
3	.312"	$1\frac{3}{4}$ "	$1\frac{7}{8}$ "	$1\frac{33}{32}$ "	$\frac{5}{8}$ "	.197"	$\frac{1}{8}$ "	$\frac{3}{16}$ "	.500"
3	.312"	2"	$2\frac{1}{8}$ "	$1\frac{31}{32}$ "	$\frac{5}{8}$ "	.197"	$\frac{5}{16}$ "	$\frac{3}{16}$ "	.500"
4	.35"	$1\frac{1}{4}$ "	$1\frac{3}{8}$ "	$1\frac{13}{16}$ "	$\frac{11}{16}$ "	.228"	$\frac{11}{32}$ "	$\frac{7}{32}$ "	.500"
5	.45"	$1\frac{3}{4}$ "	$1\frac{7}{8}$ "	$1\frac{11}{16}$ "	$\frac{3}{4}$ "	.260"	$\frac{3}{8}$ "	$\frac{1}{4}$ "	.500"
6	.50"	$2\frac{3}{8}$ "	$2\frac{1}{2}$ "	$2\frac{9}{16}$ "	$\frac{7}{8}$ "	.291"	$\frac{7}{16}$ "	$\frac{9}{32}$ "	.500"
6	.50"	$3\frac{1}{4}$ "	$3\frac{3}{8}$ "	$3\frac{11}{16}$ "	$\frac{7}{8}$ "	.291"	$\frac{7}{16}$ "	$\frac{9}{32}$ "	.500"
7	.60"	3"	$3\frac{1}{8}$ "	$2\frac{29}{32}$ "	$\frac{15}{16}$ "	.322"	$\frac{15}{32}$ "	$\frac{5}{16}$ "	.500"
7	.60"	4"	$4\frac{1}{8}$ "	$3\frac{29}{32}$ "	$\frac{15}{16}$ "	.322"	$\frac{15}{32}$ "	$\frac{5}{16}$ "	.500"
8	.75"	$3\frac{9}{16}$ "	$3\frac{11}{16}$ "	$3\frac{29}{16}$ "	1"	.353"	$\frac{1}{2}$ "	$\frac{11}{32}$ "	.500"
9	.90"	4"	$4\frac{1}{8}$ "	$3\frac{7}{8}$ "	$1\frac{1}{8}$ "	.385"	$\frac{9}{16}$ "	$\frac{3}{8}$ "	.500"
10	1.0446"	5"	$5\frac{1}{8}$ "	$4\frac{27}{32}$ "	$1\frac{5}{8}$ "	.447"	$\frac{21}{32}$ "	$\frac{7}{16}$ "	.5161"
10	1.0446"	$5\frac{11}{16}$ "	$5\frac{13}{16}$ "	$5\frac{17}{32}$ "	$1\frac{5}{8}$ "	.447"	$\frac{21}{32}$ "	$\frac{7}{16}$ "	.5162"
10	1.0446"	$6\frac{7}{32}$ "	$6\frac{11}{32}$ "	$6\frac{1}{8}$ "	$1\frac{5}{8}$ "	.447"	$\frac{21}{32}$ "	$\frac{7}{16}$ "	.5162"
11	1.25"	$6\frac{3}{4}$ "	$6\frac{7}{8}$ "	$6\frac{19}{32}$ "	$1\frac{5}{8}$ "	.447"	$\frac{21}{32}$ "	$\frac{7}{16}$ "	.500"
12	1.50"	$7\frac{1}{8}$ "	$7\frac{1}{4}$ "	$6\frac{15}{16}$ "	$1\frac{1}{2}$ "	0.510"	$\frac{3}{4}$ "	$\frac{1}{2}$ "	0.500"

The angle on the end of tongue on milling cutters and arbors, and the angle of the keys for driving cutters from collets may be made the same as for twist drills.

Radius of mill for cutting tongue may be the same as for twist drill shanks.

THE JARNO TAPER

The taper per foot for all numbers in this system is 0.600"

Formulas for various sizes of tapers are as follows:

N = number of Jarno taper.

D = diameter at large end of taper.

d = diameter at small end of taper.

L = length of taper.

$$D = \frac{N}{8}$$

$$d = \frac{N}{10}$$

$$L = \frac{N}{2}$$

The various clearance and tongue dimensions for the Jarno taper may be taken from the Brown and Sharpe list, with slight modifications.

TABLE XIV. — THREADS FOR PIPE SIZES. PIPE TAP DRILLS

Diam. of tap . . .	$\frac{1}{8}$ "	$\frac{1}{4}$ "	$\frac{3}{8}$ "	$\frac{1}{2}$ "	$\frac{3}{4}$ "	1"	$1\frac{1}{4}$ "	$1\frac{1}{2}$ "	2"	$2\frac{1}{2}$ "	3"	
Threads per inch	27	18	18	14	14	$11\frac{1}{2}$	$11\frac{1}{2}$	$11\frac{1}{2}$	$11\frac{1}{2}$	8	8	All diameters above 3", 8 threads per inch.
Diam. of tap drill	$\frac{11}{32}$ "	$\frac{7}{16}$ "	$\frac{37}{64}$ "	$\frac{45}{64}$ "	$\frac{29}{32}$ "	$1\frac{9}{64}$ "	$1\frac{1}{2}$ "	$1\frac{23}{32}$ "	$2\frac{3}{16}$ "	$2\frac{5}{8}$ "	$3\frac{1}{4}$ "	

For good work, a pipe reamer should follow the drill before tapping, but in a great deal of work, the tap is used directly after the drill and gives satisfactory results.

TABLE XI. — PROPERTIES OF UNITED STATES STANDARD
THREAD

Diameter of bolt	Number threads per inch	Size of tap drill or size to bore to form thread
$\frac{1}{4}$ "	20	$\frac{3}{16}$ "
$\frac{5}{16}$ "	18	0.242" or $\frac{1}{4}$ "
$\frac{3}{8}$ "	16	.302" or $\frac{5}{16}$ "
$\frac{7}{16}$ "	14	.348" or $\frac{11}{32}$ "
$\frac{1}{2}$ "	13	$\frac{13}{32}$ "
$\frac{9}{16}$ "	12	$\frac{29}{64}$ "
$\frac{5}{8}$ "	11	$\frac{37}{64}$ "
$\frac{3}{4}$ "	10	$\frac{5}{8}$ "
$\frac{7}{8}$ "	9	$\frac{33}{32}$ "
1"	8	$\frac{7}{8}$ "
$1\frac{1}{8}$ "	7	$\frac{9}{8}$ "
$1\frac{1}{4}$ "	7	$1\frac{5}{8}$ "
$1\frac{3}{8}$ "	6	$1\frac{11}{8}$ "
$1\frac{1}{2}$ "	6	$1\frac{13}{8}$ "
$1\frac{5}{8}$ "	$5\frac{1}{2}$	$1\frac{25}{8}$ "
$1\frac{3}{4}$ "	5	$1\frac{1}{2}$ "
$1\frac{7}{8}$ "	5	$1\frac{5}{8}$ "
2"	$4\frac{1}{2}$	$1\frac{33}{8}$ "
$2\frac{1}{4}$ "	$4\frac{1}{2}$	1.970"
$2\frac{1}{2}$ "	4	2.185"
$2\frac{3}{4}$ "	4	2.435"
3"	$3\frac{1}{2}$	2.638"
$3\frac{1}{4}$ "	$3\frac{1}{2}$	2.888"
$3\frac{1}{2}$ "	$3\frac{1}{4}$	3.110"
$3\frac{3}{4}$ "	3	3.327"
4"	3	3.576"
$4\frac{1}{4}$ "	$2\frac{7}{8}$	3.808"
$4\frac{1}{2}$ "	$2\frac{3}{4}$	4.037"
$4\frac{3}{4}$ "	$2\frac{5}{8}$	4.265"
5"	$2\frac{1}{2}$	4.490"
$5\frac{1}{4}$ "	$2\frac{1}{2}$	4.740"
$5\frac{1}{2}$ "	$2\frac{3}{8}$	4.963"
$5\frac{3}{4}$ "	$2\frac{5}{8}$	5.213"
6"	$2\frac{1}{4}$	5.433"

TABLE XV

This table gives sizes of Morse Taper Shanks for use on twist drills of various diameters. It is a guide for use of taper shanks on counterbores.

#1 shank is used on drills of the following diameters: $\frac{1}{4}$ " , $\frac{5}{16}$ " , $\frac{3}{8}$ " , $\frac{7}{8}$ " , $\frac{1}{2}$ " , $\frac{9}{16}$ " .

#2 shank is used on drills of the following diameters: $\frac{5}{8}$ " , $1\frac{1}{8}$ " , $\frac{3}{4}$ " , $1\frac{3}{8}$ " , $\frac{7}{8}$ " .

#3 shank is used on drills of the following diameters: $1\frac{5}{8}$ " , 1" , $1\frac{1}{8}$ " , $1\frac{1}{8}$ " , $1\frac{3}{8}$ " , $1\frac{1}{4}$ " .

#4 shank is used on drills of the following diameters: $1\frac{5}{8}$ " , $1\frac{3}{8}$ " , $1\frac{7}{8}$ " , $1\frac{1}{2}$ " , $1\frac{9}{16}$ " , $1\frac{5}{8}$ " , $1\frac{1}{8}$ " , $1\frac{3}{4}$ " , $1\frac{1}{8}$ " , $1\frac{7}{8}$ " , $1\frac{5}{8}$ " , 2" .

#5 shank is used on drills of the following diameters: $2\frac{1}{8}$ " , $2\frac{1}{8}$ " , $2\frac{3}{8}$ " , $2\frac{5}{8}$ " , $2\frac{3}{8}$ " , $2\frac{7}{8}$ " and all larger diameters.

This table serves as a guide for selecting shanks for counterbores. Do not use a smaller shank than #2 on any diameter of counterbore.

BIBLIOGRAPHY

The young man who is ambitious should begin very early in his career to build a library for his future use. The civilization of past ages has come to us very largely through the medium of books. The experiences of preceding generations of skilled workers is recorded in certain written texts. Again through the medium of books we can get knowledge of methods of work adopted by plants at great distances from our homes which we could never expect to visit personally.

A good text book, furthermore, presents only those features of an industry which have been reduced to practice, and is therefore not only a source of information, but the information contained therein is selected and well classified.

No one text can possibly contain all the valuable information used in the practice of any one of the leading trades of our day; no set of books by any one author will contain all such information. A well selected lot of books, by different authors will prove of material value to the young man who is learning or practicing a trade.

The books listed in this brief bibliography will prove helpful to the machinist. The author has used them in classes himself and is sure of their value as aids in industrial education. The order in which the books are named is not an evidence of their value; each text is equally valuable, when its purpose is considered. These books can be obtained from any dealer.

Machine Shop Practice, by Kaup. — This book is a general survey of the elementary work of the machine shop of our day. It does not go into detail. It may be

regarded as a text presenting the generalities of machinery production, in a simple and direct manner.

Machine Tool Operation, by Burghardt. — A text going into considerable detail particularly relating to lathe operation. The text does not aim to cover the machinist's trade as a whole, but presents a great many interesting and helpful hints. The author has been a successful teacher of machine shop practice for many years. The book will prove of value to any man who likes a machine shop.

Advanced Machine Work, by Smith. — This book is written in the form of a number of directions as to methods of doing various jobs. The student should have taken elementary machine practice before attempting to use this text. The book is a mine of valuable detail relating to machine shop practice, all of which is carefully presented.

Machinery's Handbook. — This is just what the title implies; it is a handbook of the machinery trade. Like Smith's book, the learner should have elementary preparation before attempting to use this book. A very valuable book for any person working in the machine shop.

Practical Treatise on Gearing. Brown and Sharpe Mfg. Co. — A very good book for the practical machinist. Each subject taken up is definitely related to shop practice. There is no advanced mathematical work introduced, but there is plenty of good wholesome thinking required to master the contents of the work.

A Treatise on The Planer. The Cincinnati Planer Co. — A practical text dealing with the operation and upkeep of the planer. Many special methods of handling work are described.

The Gisholt Turret Lathe Guide. Gisholt Machine Co. — A book presenting many good points on operating the Gisholt machine. Many good points on "set

up" which can be applied to other machines than the Gisholt tool.

American Machinist Gear Book, by Logue. — A text dealing with the subject of gearing in a very satisfactory manner. A very good course of study in gearing is Brown and Sharpe's text, followed by this book. To get the most out of the American Machinist Gear Book, the student should have a knowledge of geometry and trigonometry.

Accurate Tool Work, Goodrich and Stanley. — This book deals with the practical features of fine tool making. Very good for the machinist who is anxious to enter the tool making field.

How to Read a Blueprint, by Getty. — A book dealing in a practical way with the elements of drawing. The conventionalities of the drawing room are explained in so far as they relate to the practical features of shop work.

COURSE OUTLINE

ELEMENTARY MACHINE SHOP PRACTICE

The following course outline is presented as a guide to those interested. The various jobs given in connection with each trade process are articles of use in the machine shop. In a commercial shop the instructor can find many jobs which present the desired trade step, and it is advisable to use such. In cases where the line manufactured by the firm will not supply all the trade processes the job list given will serve as an efficient guide. It is essential in trade training that important processes shall not be neglected, if we wish to produce a supply of all around workmen.

In the school shop, the outline will prove of assistance in rounding out the course where a selected or available line of work may not supply all the trade processes. All the articles mentioned can be made much more cheaply in the school than they can be purchased on the market.

Any trade course outline must be laid down to fit the organization in which it is to operate. A program that may work out most satisfactorily in one community may not prove a success in another because of varying local conditions. It is necessary therefore to adapt the course, in so far as its job content is concerned, to the plant or school in which it is to operate. In a full trade course the process outline should not be widely departed from.

The teacher of manual training or prevocational classes may select from the trade course such processes as best meet the requirements of his work.

The course is built around the trade process, not around the job. This arrangement is both efficient and effective; with each process entry appear several jobs, to which

reference has already been made. These jobs are the means of developing skill in the desired process.

The outline starts with work at the bench, but it is not absolutely necessary that the learner start at the bench. For a full trade course, the bench serves admirably as a starting point. The early processes at the bench are simple, and the equipment used is easily understood.

In teaching all trades the author has followed a concentric plan. On such a plan the learner starts, for example, at the bench, taking the first half dozen processes, possibly, then going to the lathe taking the early processes, thence to drill press, shaper, miller and slotter taking the first few processes on each machine. After completing the round the learner returns to the bench and takes another series of processes, somewhat more advanced than the first series taken. The same circuit of machines is repeated on somewhat more advanced work.

The order in which the machines are taken is not important; the learner may pass from bench to shaper, miller, or slotter just as well as from bench to lathe. It is important, however, that the learner start on elementary processes when beginning on a machine. He should not begin with an advanced process and follow with an elementary one; such a plan retards the development of skill.

TRADE STEPS AND RELATED WORK ¹

BENCH WORK

Plain Chipping. — Gage blocks, block parallels, clamp blocks, planer stops and stakes. Refer to text for method of work.

¹ Prints giving process content for each job mentioned may be purchased from Minot H. Pratt, Media, Delaware Co., Pa. These are illustrative prints showing job and related process. Prints are not dimensioned.

Use of Steel Stamps. — Marking sizes and shop numbers on all work made. Refer to text for method.

Use of Hack Saw. — Cutting of stock for bolts. Refer to text for method.

Flat Filing. — Same as for plain chipping. Refer to text for method.

Use of Outside and Inside Caliper. — Assignment in measuring standard work. Careful instructions as to method of use, and transfer of dimensions between scale, outside and inside caliper. Refer to text for method.

Belt Lacing. — Sample pieces made up for learner to study; unlace and lace until arrangement of lace is learned. Be sure necessity for squaring ends of belt is explained. See text for method.

Use of Micrometer Caliper. — Study instrument carefully; instruction in method of reading. Select several pieces of various diameters; arrange in a given order; have the learner measure these and list measurements, as he reads them from the instrument. Be sure to have some fractional measurements in half thousandths. Have several pieces with bored holes listed in order. Pieces to have holes of various diameters. Let learner measure these with inside caliper, transfer size to micrometer and list measurements, as read. This is excellent practice in developing the sense of touch and accuracy in the use of the micrometer caliper. Refer to text for method of using inside caliper and the micrometer.

Use of the Vernier Caliper. — Follow the same plan as outlined for the micrometer.

Use of the Speed Indicator. — Careful study of instrument. Assign to read speed of several rotating parts of various machines in the shop. Machines taken in a specific order, and speeds recorded in same order. Refer to small tool catalog for study of instrument.

Use of Taps. — Have a supply of blank nuts available; same of size in use about shop. Assign learner to tapping

a given number. See that learner understands squaring tap with face of nut when starting the tap. Refer to text for material on taps.

Use of Threading Dies. — Assign to going over a certain number of clamp bolts in use about shop. Clean up threads; saw off damaged threads and cut new threads. Cut threads on such rough bolts as you want about the shop, by means of the die. Be sure learner is taught to start the die square. Some work should be done with set die, and some with "jam" die. Refer to text for data on threads.

Laying Out. — Laying out clamps for ratchet work. Laying out oil can parts for soldering and sweating work. Laying out any of the jobs given in this outline for shaper, planer or slotter.

Use of the Ratchet. — Have learner make at least two clamps as follows: On the end of a steel bar of required dimensions lay out the clamps. Lay out holes for slot in clamp and drill these with ratchet. Saw off the clamp with hack saw. Broach out and file the slot. Trim ends of clamp to desired form by means of chisel and files. The whole clamp is made without a power tool. A knowledge of the processes involved is very valuable to the mechanic who may be sent out on a repair or erection job. Refer to text for ratchet "set up."

Broaching and Drifting. — See job listed for ratchet work.

Soldering and Sweating. — Make at least one conical oil can. A satisfactory size is $3\frac{1}{2}$ " at base with $\frac{3}{4}$ " hole at top; solder in a $\frac{3}{4}$ " nipple drilled and tapped for a $\frac{5}{8}$ " 16 thread. This includes making base and spout. See text for method of soldering.

Chipping and Filing Keyways. — Fitting keys to planer and miller vises, planer jack bases, V-blocks, miller arbors; compound bushings, gears for lathe change gear sets, and

for stock, cutter heads and boring bars. It is a good plan to have a number of V-blocks, jack bases, fitted with keys which in turn fit in T-slots of miller and planer. These blocks and bases are very convenient for a great deal of work. See text on shaper and slotter for layout of keyways on internal and external cylindrical work.

Calculating Cutting Speed. — Assign learner several jobs going on in the shop; these to be taken in a specified order and calculations made for each. The results to be tabulated. See text for method of calculation.

Scraping, Spot and Bearing. — Keep bases of all miller and planer fixtures well spotted and free from burrs. For accurate surface scraping, keep a supply of various size surface plates. Have some knees of various sizes scraped accurately to bearing and surfaces at right angle. These are very convenient for laying out work. See text for method.

Cylindrical Scraping to Bearing. — Have a set of main spindle bearing boxes made up for each machine in shop, and keep in stock. Let these be carefully scraped to a gage, the same size as spindle they are to fit. The spindle boxes of machines in continual operation should be opened frequently, and boxes re-scraped to bearing. When bearing becomes excessively worn, replace with a new bearing. The lathes in most shops are much neglected in this respect, particularly the speed lathes. See text for method of cylindrical scraping.

Forge Work. — Preparation of fire, forging chisels, broaches, screw drivers, cutting-off tools, side tools, brass tools, diamond points. See Forging of Iron and Steel by Richards (D. Van Nostrand Co).

Hardening and Tempering. — Harden and temper tools given in above list. See text for method.

THE DRILL PRESS

Grinding of Drills. — Fitting new drills for use. Upkeep of stock in tool room.

Reamer Drilling, Tap Drilling, Pipe Tap Drilling. Have the learner lay out a piece of stock of required size, which introduces the required kind of work; that is one reamer drill hole, $\frac{3}{4}$ " diam., one $\frac{3}{4}$ " tap drill, and one $\frac{3}{4}$ " pipe tap drill. This project should be clearly explained, so the learner understands the difference in the classification of the tools. The holes should be reamed and tapped. Extend practice on planer strips, planer stakes, nut blanks, cutter blanks, clamps, planer clamp strips, planer jacks, angle plates. See text for details.

Countersinking and Counterboring. — Lay out a piece of stock from a prepared drawing introducing this work. Carefully instruct learner on importance of bringing countersinking and boring to proper depth. Oil guide teat of counterbore when in use. Extend practice on vise parts, hardening press parts, monkey wrench parts, dogs, vise pin jaws, boring tool holders, drill holders, planer jacks, try squares, wedge parallels.

Drilling Cylindrical Work. — Collets, boring bars, tool posts, ratchet spindles, inserted cutter counterbores. See text for method.

LATHE WORK

Centering, Facing, Turning, Shouldering, Chamfering, Filing. — Mandrels, end mills, drills, reamers, taps, bolts, nuts, cutters. See text for methods of doing various kinds of work.

Thread Cutting, Right and Left Hand; Inside and Outside. — Bolts, jack screws, arbor nuts, threading dies,

310 PRACTICAL MACHINE SHOP PRACTICE

planer jacks, and screws, for same, vise screws, monkey wrench screws (left hand). See text for method of working.

Lathe Fitting, Running Fits. — Pin jaws, milling machine arbors, boring bars, miller arbor bushings, ratchet brace parts, boring tool holders, boring tool blanks, hardening press parts, ratchet parts, vise parts, machine reamer shanks. See text for data.

Lathe Fitting, Drive and Shrink. — Ratchet brace parts, machine reamer parts, small tap wrenches, vise screws, jack bases. See text for data.

Use of Follow and Back Rest. — Push rods, bolt bodies, twist drills, reamer blanks, die holder handles, die holder bodies. See text for method.

Taper Turning and Fitting. Poppet Head and Taper Attachment Method. — Collects, drills, end mills, lathe centers. See text for method.

Knurling. — Tap wrench and die handles, screw driver handles, ratchet feed nuts.

Angular Turning. — Angular cutters, lathe centers, countersinks. See text for method.

Use of Center Indicator. — Threading dies, die holders, safety dogs. See text for method.

Face Plate Work. — See under center indicator.

Eccentric Turning. — Drill holders, safety dogs. See text for method.

Taper Boring. — Collets, sleeves, ratchet spindles, drill holders, taper gages. See text for data.

• THE SLOTTER

Surface Work and Cornering. — Fly tool holders, monkey wrench parts, lathe dogs, ratchet parts. See text for method.

Key Way Cutting. — Gears, ratchet parts, miller arbor bushings, milling cutters. See text for method.

Radial Work. — Lathe dogs, monkey wrench parts, die holders, ratchet parts. See text for method.

PLANER AND SHAPER

Surface Work, Shoe and String Work. — V-Blocks, angle plates, surface plates, planer rib pieces, straight parallels, wedge parallels, wedge jaws for vise, key seat rules. See text for method.

Angular Work, Undercutting. — V-Blocks, tap wrenches, centering y's, miller and grinder dogs, tap wrench parts, vise jaws, boring tool holders. See text for methods.

Radial and Indexing Work. — Standard nuts, jack screw heads, safety lathe dogs, monkey wrench parts, die holders, drill holders, ratchet parts, miller and grinder dogs. See text for method.

Key Way Cutting. — Vise screws, miller arbors, jack screws, machine reamer shanks, ratchet and ratchet brace parts, breast drill parts, universal chuck parts. See text for method.

THE MILLING MACHINE

Slabbing. — Vise parts, die holders, monkey wrench parts, tap wrenches, boring tool holders, wedge parallels, V-blocks. See text for data.

End Milling and Vertical Milling Attachment Work. — Chuck parts, tap wrench parts, monkey wrench parts. See text for method.

Straddle Milling. — Standard nuts and bolt heads for general shop use. See text for method.

Simple Indexing. — Milling cutters, end mills, reamers, taps, gears. See text for data.

HARDENING AND ANNEALING

Open Fire Heating; Water Anneal; Ash Anneal. — Hardening and tempering chisels and lathe tools, cutters, taps, lathe centers, end mills. Annealing such tools when worn down, so they may be reclaimed.

THE GRINDER

Testing the Machine. — See text for method.

Straight Traverse Grinding. — (Use the steady rests.) Drills, reamers, mandrels, bolt bodies, taps, machine reamer shanks. See text for data.

Face Grinding. — Threading dies, vise screws, slab mills, side mills, angular mills. See text for data.

Taper Grinding. — Centers, drills, collets, sleeves. See text for data.

Angular Grinding. Angular cutters, centers, countersinks.

In the operation of this course outline in a school shop it is assumed that the classes make all mandrels, drills, reamers, cutters, gages, dogs, clamps, bench vises, breast drills, ratchets, bench centers, planer jacks, floor jacks, hardening presses, ratchet braces (old men) and adjustable blade try squares that are used by the metal trades sections.

INDEX

	PAGE		PAGE
A			
Acid-muriatic	56	Brown and Sharpe taper; proportions	296
Annealing	64	Books for machinists	299
Anneal; water	64	Bibliography	299
Adjusting machinery	66	Box shim	66
Analysis; machine	97	C	
Angular turning	139	Copper jaws	3
Anchored tool	171	Chipping; method	6
Angular vernier	256	Chipping; instructions	6
Angular vernier; reading	257	Caliper; vernier; microm- eter	16
Acid; coloring	274	Caliper; micrometer	20
Accurate centering	33, 34, 35	Circular measure	23
B		Center punch	27
Bench machinists	2	Caliper; outside	27
Bench stool	2	Caliper; inside	28
Bench; proper position at	5	Caliper; hermaphrodite	30
Bench work; instructions concerning method	5	Catalog; small tool	31
Bearings; providing for lu- brication	14	Center square	32
Bevel protractor	25	Cylindrical work; laying out for drilling	33, 34, 35
Bevel	25	Centering; accurate	33, 34, 35
Box square	36	Carrier	40
Box; taper shell	70	Center gauge	43
Bolts; standard	72	Cloth; emery	43
Belting	76	Center indicator	51
Belt lacing	76	Caliper; transfer	53
Belt upkeep	78	Calipers; classification	54
Brass	80	Check nut	68
Babbitt	81	Crowning; on pulleys	71
Brass tool	91	Cotter pins	74
Brown and Sharpe taper	125	Centering Y	95
Back rest	135	Center square	96

PAGE	PAGE		
Centering	101	Coolant for grinding	274
Center; truing	102	Cotter pins	287
Center; live	102	Cutting speed table	292
Center; dead	102	Course outline; see appendix	
Cutting off	106	Cylindrical scraping	13
Chuck work	106	Castings; general notes on	78
Cutting a left-hand thread	120	Crucible machine steel	79
Cutting internal threads	120	Cutting speeds	79
Classification of tapers	126		
Compound rest	139	D	
Collet; long	147	Divider	31
Collet; short	147	Drill; reamer	41
Chuck; hand for drill press	148	Drill; tap	41
Counterbore; solid	148	Drill; tap sizes; table	2
Counterbore; inserted cutter	148	Drill gages	45
Countersink	148	Depth gage	49
Countersink; angle for wood and machine screws	149	Drills; sizing by letters	75
Cylindrical work; drilling	155	Dresser; emery wheel	83
Cylindrical work on slotter	177	Diamond point; lathe and planer	90
Coolant for grinding	196	Dead center	103
Centers; milling	208	Drill press	147
Cutters; gear	228	Drill; sensitive	150
Cutters; involute	228	Drill; upright	149
Cutters; epicycloidal	230	Drill press; operating	152
Cutting gears	231	Drill; pod	153
Clamps; planer	240	Drill; twist; names of parts	154
Calculations; machine shop	252	Die; pipe threading	154
Calculating surface speed	257	Drilling cylindrical work	155
Calculating speed of pulleys	259	Drill press; use of vise on	156
Calculating speed of gears	259	Diamond	190
Calculating gears for thread cutting on engine lathe	263	Driving fit	293
Compound in thread gear train	264	Dividing head; milling machine	212
Calculations; simple indexing	269	Drills; standard shanks for	298
Coloring acid	274		
Cutting compound	274	E	
		Emery cloth; grading	43
		Emery wheel dresser	83

	PAGE		PAGE
Engine lathe.....	98, 99	Gage; surface.....	32
Elastic wheel.....	185	Gage; surface; use of for accurate centering.....	33
Epicycloidal gear cutters... ..	230	Gage; center.....	43
English measure; table....	15	Gages; wire and drill.....	45
Eccentric turning.....	141	Gages; table of wire and drill; see table 3	
F			
Faces; leather for vise jaws.	4	Gage; thread.....	48
File card.....	7	Gage; thickness.....	49
File blank.....	7	Gage; depth.....	49
Files; shapes used in shop..	7	Gage; scratch.....	49
Files; common lengths....	7	Gasoline torch.....	54
File; catalog.....	7	Gas furnace.....	65
File "Filosofy".....	8	Gib.....	69
Files; cuts used in machine shop.....	8	Gage; twist drill.....	75
File handles.....	8	Grindstone.....	81
File; placing handle.....	8	Grinding wheel; mount- ing.....	85
Filing; correct position for.	8	Grinder; tool post.....	103
Filing; method.....	9	Gears; setting for thread cutting.....	116
Flux.....	56	Gears; selective for thread cutting.....	117
Forge.....	60	Gears; calculating for thread cutting.....	123
Furnace; gas.....	65	Grinder.....	181
Feather key.....	73	Grinding wheels; grading..	184
Facing.....	102	Grinding wheel; vitrified..	185
Face plate; removing.....	107	Grinding wheels; elastic... ..	185
Facing work.....	103, 110	Grinding; method.....	186
Filing; in the lathe.....	110	Grinding; work speed....	186
Fitting.....	111	Grinding; classification of methods.....	187, 188
Fitting a taper.....	124	Grinding wheels; truing... ..	189
Follow rest.....	135	Grinder; steady rest.....	192
Fits; table of allowance for various.....	293	Grinding; preparation of work for.....	193
G			
Graduations; for scale....	16	Grinding; coolant for.....	196
Graduations; see table....	1	Grinding; internal.....	198
Gage; standard snap.....	22	Grinding; taper.....	192
Gage; plug and ring.....	22	Grinder; testing.....	203
Gage; taper.....	23		

	PAGE		PAGE
Gearing	220		
pitch of gear	220		
pitch diameter	222		
addendum	223		
tooth depth	223		
dedendum	223		
pitch defined	223		
rules for calculation	224, 225, 226, 227, 228		
Gear set; progression of	265		
Glossary	273		
Graduations; steel rule	283		
Grinding wheels; mounting			
data	293		
Gage; screw pitch	48		
Gage; taper	126		
Grinding twist drill	149		
Gear cutting; work method	231		
H			
Hammer; machinists	5		
Hardening steel	5		
Hammer; proper holding	5		
Handles; file	8		
Handle; placing on file	8		
Hermaphrodite caliper	30		
Hardening	60		
Hardening high-speed steel	63		
Hog nose tool	91		
Hack saw	37		
Hammer; lead	39		
I			
Inside caliper	28		
Inside caliper setting	29		
Indicator; test	50		
Indicator; center	51		
Index centers	212		
Indexing; simple	213		
Involute cutters	228		
Internal grinding	198		
		J	
		Jaws; copper	3
		Jaws; taper for vise	4
		Jaws; pin for vise	4
		Jig; soldering	56
		Journal	67
		Jarno taper	297
		K	
		Key seat rule	36
		Key; Woodruff	73
		Kettle; soda	87
		Knurl	95, 96
		Key way cutting on shaper	169
		Key way cutting on slotter	178
		Key; Woodruff	286
		Keys; taper	73
		L	
		Leather face for vise jaw	4
		Lead; red	11
		Lubrication; providing for	14
		Linear measure	15
		Level	36
		Lead hammer	39
		Lacing a belt	76
		Lathe tools	90
		Lathe; engine	98, 99
		Live center	103
		Lathe; testing	104
		Lathe; approximate method	
		of testing	105
		Length of work; measuring	106
		Lubricant; for forcing fits	112
		M	
		Machinist's trade; require-	
		ments	1
		Measurement; linear	15
		Micrometer caliper	16, 20, 21
		Measure; circular	23

PAGE		PAGE	
Monkey wrench	38		
Mandrel	39	P	
Measure; paper	43	Pin jaws for vise	4
Marking stamp	54	Plate; surface	10
Machinery; adjusting	66	Protractor; bevel	25
Machine screws	75	Prick punch	27
Machine steel; open hearth	79	Paper measure	43
Mounting grinding wheels	85	Pulley	71
Mandrel press	87	Pins; taper	73
Machine analysis	97	Pins; cotter	74
Measuring length of work	106	Polishing stand	84
Measuring threads	113	Polishing wheels	85
Micrometer caliper for threads	114	Press; mandrel	87
Milling machine	206	Parting tool	91
Milling cutters; various kinds	208	Parting	106
Milling machine; methods of work	209	Pipe die	154
Milling machine dividing head	212	Planer	234
Milling; straddle	217	Planer small tool equip- ment	234, 235, 237, 238, 239
Machine tools; sizing clas- sification	280	Planer clamps	240
Machine screws; gages, numbers, standard threads	288	Planer testing	241
Machine screws; A. S. M. E. standard	289	Planer; method of work	243
Morse taper properties	295	Progression of gear set	265
N		Pins; cotter	287
Nuts; standard	72	Pulley crowning	71
Nut mandrel	123	Pod drill	154
Nut; check	68	Pipe thread table	297
O		R	
Oil stone	10	Red lead	11
Outside caliper	27	Rule; steel	16
Oakum	45	Reamer	40
Open hearth machine steel	79	Reamer drill	41
		Ratchet	57
		Removing lathe faceplate	107
		Running fit	293
		Round nose tool	95
		Radius tool	95
		Radial work on slotter	177
		S	
		Stool; bench	2
		Steel; hardening	5

PAGE	PAGE		
Scraper for cylindrical work.	13	Soda kettle.	87, 88
Scale; graduated measuring.	16	Shovel nose tool.	95
Scale; binary graduated.	16	Square center.	96
Scraping.	9	Stud.	119
Surface plate.	10	Screws; angle of head for wood and machine.	149
Scraper; stoning.	10	Sensitive drill.	150
Stoning scraper.	10	Shaper.	157
Scraping without use of sur- face plate.	12	Shaper; tools for.	157
Scraping; cylindrical.	13	Shaper; method of working	161
Scale; steel.	16	Shaper; use of centers on.	163
Standard snap gage.	22	Shaper; key way cutting on	169
Scratch awl.	31	Slotter.	173, 175
Straight edge.	31	Slotter tools.	176
Surface gage.	32, 33	Slotter; cylindrical or radial work on.	177
Spirit level.	36	Steady rest for grinder.	192
Screw thread gage.	48	Simple indexing.	213
Scratch gage.	49	Straddle milling.	217
Socket wrench.	52	Surface speed; calculating.	257
Screw driver.	53	Speed of pulleys and gears; calculating.	259
Stamp; marking.	54	Simple indexing calcula- tions.	269
Soldering.	54	Sizing of machine tools in trade.	280
Soldering copper.	55	Steel rule graduations.	283
Solder.	55	Scale graduations.	283
Scale; temperature for tem- pering.	62	Speed; cutting.	292
Steel; high speed; harden- ing.	63	Sleeve.	147
Shaft defined.	66		
Spindle defined.	66	T	
Shims.	67	Tempering.	5
Set screws; types.	69	Taper gage.	23
Set screws.	74	Try square.	23
Screws; set.	74	Try square; testing.	24
Screws; machine.	75	Taps.	41
Steel; crucible machine.	79	Tap drill.	41
Speeds; cutting.	79	Tap drill sizes; see table 2	
Steel; tool.	79	Thickness gage.	49
Stellite.	80	Trammel points.	50
Surface speed.	84		

PAGE	PAGE		
Test indicator.....	50	Tapers used in shop practice.....	125
Transfer caliper.....	53	Taper; Brown and Sharpe.....	125
Torch; gasoline.....	54	Taper; Jarno.....	125, 297
Tempering; temperatures for.....	62	Turning tapers.....	125
Taper keys.....	73	Tapers; classification.....	126
Taper pins.....	73	Taper; setting poppet head for.....	126
Twist drill gage.....	75	Taper gage.....	126
Tool steel.....	79	Taper work; internal.....	130
Truing grindstone.....	82	Taper attachment.....	131
Tool grinder.....	82	Taper turning in degrees.....	133
Tools; lathe.....	90	Turning; angular.....	139
Tool; lathe diamond point.....	90	Turning; eccentric.....	141
Tool; planer diamond point.....	90	Twist drill grinding.....	149
Tool; brass.....	91	Twist drill parts.....	154
Tool; hog nose.....	91	Tools for shaper.....	157
Tool; parting.....	92	Tool; anchored.....	171
Tool; threading.....	93	Tools; slotter.....	176
Tool; right and left hand side.....	94	Taper grinding.....	202
Tool; shovel nose.....	95	Testing grinder.....	203
Tool; round nose.....	95	Testing planer.....	241
Tool; radius.....	95	Threads; calculating gears for.....	263
Turning.....	101	Tap drills for machine screws.....	288
Tool post grinder.....	103	Threads for machine screws A. S. M. E.....	289
Testing lathe.....	104	Tap drills for A. S. M. E. standard machine screws.....	289
Thread cutting; setting gears for.....	116, 284, 294	Twist drill gage; decimal equivalents.....	290
Thread; U. S. S.....	113, 115	Twist drill gage; decimal equivalents of letter sizes.....	291
Thread; measuring.....	113	Tap drill for U. S. Std. thread.....	294
Thread micrometer.....	114	Taper; properties of Morse.....	295
Thread; right hand.....	118	Taper; properties of Brown & Sharpe.....	296
Thread; left hand.....	118		
Thread bushing.....	120		
Thread; cutting left hand..	120		
Thread; cutting internal...	120		
Thread tool; grinding.....	122		
Thread cutting; calculating gears for.....	123		
Taper fitting.....	124		

	PAGE		PAGE
Threads; table of pipe	297	Vitrified grinding wheels . . .	185
Taper shanks; proper sizes for various diameters of drills	298	Vernier; method of laying out	253
Taper jaws for bench vise . .	4	Vernier; angular	256
Tempering	60	Vernier; reading angular	257
		W	
U		Wrenches; miscellaneous . .	42
Use of mandrel	109	Waste; cotton	44
U. S. S. thread	115	Wrenches; socket	52
Upright drill	149	Washers	72
U. S. S. thread; tap drill for.	284	Woodruff keys; see table 4	73, 286
V		Wheels; polishing	85
Vise for machinist	3	Wire gages; table	285
Vernier caliper	16, 22	Wire gages	45
Vise; use on drill press	156	Wiggler; see center indicator	

D. VAN NOSTRAND COMPANY
8 WARREN STREET
NEW YORK

SHORT-TITLE CATALOG
OF
Publications & Importations
OF
**SCIENTIFIC AND ENGINEERING
BOOKS**



**This list includes the technical publications of the following
English publishers:**

SCOTT, GREENWOOD & CO. JAMES MUNRO & CO., Ltd.
CONSTABLE & COMPANY, Ltd. TECHNICAL PUBLISHING CO.
BENN BROTHERS, Ltd.

for whom D. Van Nostrand Company are American agents

Descriptive Circulars sent on request.

October, 1929

SHORT-TITLE CATALOG
OF THE
Publications and Importations
OF
D. VAN NOSTRAND COMPANY
8 WARREN STREET

All bindings are in cloth unless otherwise noted

Prices subject to change without notice.

Abbott, A. V. The Electrical Transmission of Energy....	8vo,	6 00
— A Treatise on Fuel.....	16mo,	0 75
— Testing Machines	16mo,	0 75
Abraham, H. Asphalt and Allied Substances.....	8vo,	5 00
Adam, P. Practical Bookbinding.....	12mo,	*2 50
Adams, H. Theory and Practice in Designing.....	8vo,	*2 50
Adams, H. C. Sewage of Seacoast Towns.....	8vo,	*2 50
Adams, J. W. Sewers and Drains for Populous Districts...	8vo,	2 50
Addyman, F. T. Practical X-Ray Work.....	8vo,	5 00
Adler, A. A. Theory of Engineering Drawing.....	8vo,	*2 50
— Principles of Parallel Projecting-Line Drawing....	8vo,	1 25
Aikman, C. M. Manures and the Principles of Manuring.	8vo,	
		(Reprinting.)
Aitken, W. Manual of the Telephone.....	8vo,	*8 00

d'Albe, E. E. F. Contemporary Chemistry.....	12mo,	1 50
Alexander, J. Colloid Chemistry.....	12mo,	1 00
Allan, W. Strength of Beams under Transverse Loads.	16mo,	0 75
Allan, W. Theory of Arches.....	16mo,	
Allen, H. Modern Power Gas Producer Practice and Applications	12mo, (<i>Reprinting.</i>)	
Anderson, J. W. Prospector's Handbook.....	12mo,	2 00
Andes, L. Vegetable Fats and Oils.....	8vo,	*6 00
— Animal Fats and Oils.....	8vo,	6 00
— Drying Oils, Boiled Oil, and Solid and Liquid Driers. .	8vo,	*6 00
— Iron Corrosion, Anti-fouling and Anti-corrosive Paints.	8vo,	*6 00
— Oil Colors and Printers' Ink.....	8vo,	4 00
— Treatment of Paper for Special Purposes.....	12mo,	*3 00
Andrews, E. S. Reinforced Concrete Construction.....	12mo,	*2 00
— Theory and Design of Structures.....	8vo,	3 50
— Further Problems in the Theory and Design of Structures	8vo,	2 50
— The Strength of Materials.....	8vo,	*4 00
— Elastic Stresses in Structures.....	8vo,	9 00
Andrews, E. S., and Heywood, H. B. The Calculus for Engineers.....	12mo,	2 00
Annual Reports on the Progress of Chemistry. Fifteen Volumes now ready. Vol. I, 1904, to Vol. XV, 1919, 8vo, each.....		3 00
Argand, M. Imaginary Quantities.....	16mo,	0 75
Armstrong, R., and Idell, F. E. Chimneys for Furnaces and Steam Boilers	16mo,	0 75
Arnold, E. Armateur Windings of Direct Current Dynamos.	8vo,	*2 00
Asch, W., and Asch, D. The Silicates in Chemistry and Commerce	8vo,	7 50
Ashe, S. W., and Keiley, J. D. Electric Railways. Theoretically and Practically Treated. Vol. I. Rolling Stock	12mo,	*2 50

4 D. VAN NOSTRAND COMPANY'S SHORT-TITLE CATALOG

Ashe, S. W. Electric Railways. Vol. II. Engineering Preliminaries and Direct Current Sub-Stations.	12mo,	2 50
— Electricity: Experimentally and Practically Applied.	12mo,	*2 00
Ashley, R. H. Chemical Calculations.	12mo,	2 50
Atkins, W. Common Battery Telephony Simplified.	12mo,	*1 25
Atkinson, A. A. Electrical and Magnetic Calculations.	8vo,	*1 50
Atkinson, J. J. Friction of Air in Mines.	16mo,	0 75
Atkinson, J. J., and Williams, E. H., Jr. Gases Met with in Coal Mines	16mo,	0 75
Atkinson, P. The Elements of Electric Lighting.	12mo,	1 50
— The Elements of Dynamic Electricity and Magnetism.	12mo,	2 00
Auchincloss, W. S. Link and Valve Motions Simplified.	8vo,	2 00
Audley, J. A. Silica and the Silicates.	8vo (<i>In Press.</i>)	
Austin, E. Single Phase Electric Railways.	4to,	*5 00
Austin and Cohn. Pocketbook of Radiotelegraphy.	(<i>In Press.</i>)	
Ayrton, H. The Electric Arc.	8vo,	*5 50
Baff, W. E. Sale of Inventions.	12mo,	2 00
Baker, A. L. Quaternions.	8vo,	1 50
— Thick-Lens Optics.	12mo,	2 00
Baker, Benj. Pressure of Earthwork.	16mo,	
Baker, G. S. Ship Form, Resistance and Screw Propulsion.	8vo,	*4 50
Baker, I. O. Levelling.	16mo,	0 75
Baker, M. N. Potable Water.	16mo,	0 75
— Sewerage and Sewage Purification.	16mo,	0 75
Baker, T. T. Telegraphic Transmission of Photographs.	12mo, (<i>Reprinting.</i>)	
Bale, G. R. Modern Iron Foundry Practice. Two Volumes.	12mo.	
Vol. I. Foundry Equipment, Material Used.		*3 00
Ball, J. W. Concrete Structures in Railways.	8vo,	*2 50
Ball, R. S. Popular Guide to the Heavens.	8vo,	6 00
— Natural Sources of Power.	8vo,	*2 50

Ball, W. V. Law Affecting Engineers.....	8vo,	*3 50
Bankson, Lloyd. Slide Valve Diagrams.....	16mo,	0 75
Barham, G. B. Development of the Incandescent Electric Lamp	8vo,	*2 50
Barker, A. F. Textiles and Their Manufacture.....	8vo,	2 50
Barker, A. F., and Midgley, E. Analysis of Woven Fabrics, 8vo,		3 50
Barker, A. H. Graphic Methods of Engine Design....	12mo,	*2 00
— Heating and Ventilation.....	4to,	9 00
Barnard, J. H. The Naval Militiaman's Guide.....	16mo, leather,	1 00
Barnard, Major J. G. Rotary Motion.....	16mo,	0 75
Barnes, J. B. Elements of Military Sketching.....	16mo,	*0 75
Barnett, E. de B. Coal-Tar Dyes and Intermediates....	8vo,	3 50
— Explosives	8vo,	5 00
— Synthetic Dyes.....	8vo, (<i>In Press.</i>)	
Barrowcliff, M., and Carr, F. H. Organic Medicinal Chemicals, 8vo (<i>In Press.</i>)		
Barrus, G. H. Engine Tests.....	8vo,	*4 00
Baterden, J. R. Timber.....	8vo,	*2 50
Bates, E. L., and Charlesworth, F. Practical Mathematics and Geometry	12mo,	
Part I. Preliminary Course.....		*1 00
Part II. Elementary Course.....	12mo,	1 00
Part III. Advanced Course.....		*1 50
— Practical Mathematics.....	12mo,	*2 00
— Practical Geometry and Graphics.....	12mo,	*2 00
Batey, J. The Science of Works Management.....	12mo,	*2 00
— Steam Boilers and Combustion.....	12mo,	*2 00
Bayonet Training Manual.....	16mo,	0 30
Beadle, C. Chapters on Papermaking. Five Volumes. 12mo, each,		2 50
Beaumont, R. Color in Woven Design.....	8vo,	*6 00
— Finishing of Textile Fabrics.....	8vo,	*5 00
— Standard Cloths	8vo,	*6 00
Beaumont, W. W. Steam-Engine Indicator.....	8vo,	2 50
Bechhold, H. Colloids in Biology and Medicine.....	8vo,	5 00

6 D. VAN NOSTRAND COMPANY'S SHORT-TITLE CATALOG

Beckwith, A. Pottery.....	8vo, paper,	0 60
Bedell, F. Airplane Characteristics.....	8vo,	1 60
— The Air Propeller.....	8vo,	1 00
— The Airplane.....	8vo, (<i>In Press.</i>)	
Bedell, F., and Pierce, C. A. Direct and Alternating Current Manual.....	8vo,	*2 00
Beech, F. Dyeing of Cotton Fabrics.....	8vo,	*5 00
— Dyeing of Woolen Fabrics.....	8vo,	*3 50
Beggs, G. E. Stresses in Railway Girders and Bridges....	(<i>In Press.</i>)	
Begtrup, J. The Slide Valve.....	8vo,	*2 00
Bender, C. E. Continuous Bridges.....	16mo,	0 75
— Proportions of Pins Used in Bridges.....	16mo,	0 75
Bengough, G. D. Brass.....	(<i>In Press.</i>)	
Bennett, H. G. The Manufacture of Leather.....	8vo,	*6 00
— Animal Proteids.....	8vo (<i>In Press.</i>)	
Bernthsen, A. A Text-book of Organic Chemistry....	12mo,	*3 50
Bersch, J. Manufacture of Mineral and Lake Pigments.....	8vo,	*6 00
Beveridge, J. Papermaker's Pocket Book....	12mo,	*4 00
Binnie, Sir A. Rainfall Reservoirs and Water Supply.....	8vo,	4 00
Binns, C. F. Manual of Practical Potting.....	8vo,	*8 00
— The Potter's Craft.....	12mo,	*2 00
Birchmore, W. H. Interpretation of Gas Analysis....	12mo,	*1 25
Blaine, R. G. The Calculus and Its Applications....	12mo,	*1 75
Blanchard, W. M. Laboratory Exercises in General Chem- istry.....	12mo,	1 00
Blasdale, W. C. Quantitative Chemical Analysis.....	12mo,	*2 50
Bloch, L. Science of Illumination.....	8vo,	*2 50
Blyth, A. W. Foods: Their Composition and Analysis.....	8vo,	8 50
— Poisons: Their Effects and Detection.....	8vo,	8 50
Böckmann, F. Celluloid.....	12mo,	*2 50
Bodmer, G. R. Hydraulic Motors and Turbines.....	12mo,	5 00
Boileau, J. T. Traverse Tables.....	8vo,	5 00
Bonney, G. E. The Electro-plater's Handbook.....	12mo,	1 50
Boone, W. T. A. A Complete Course of Volumetric Analysis.	12mo,	1 50
Booth, W. H. Water Softening and Their Control....	8vo,	3 50
— Superheaters and Superheating and their Control....	8vo,	*1 50
Bottcher, A. Cranes: Their Construction, Mechanical Equip- ment and Working.....	4to, (<i>Reprinting.</i>)	

Bottler, M. Modern Bleaching Agents.....	12mo,	*2 50
Bottone, S. R. Magnetos for Automobilists.....	12mo,	*1 00
— Electro-Motors, How Made and How Used.....	12mo,	1 00
Boulton, S. B. Preservation of Timber.....	16mo,	0 75
Bourcart, E. Insecticides, Fungicides and Weedkillers..	8vo,	*6 00
Bourgougnon, A. Physical Problems.....	16mo,	0 75
Bourry, E. Treatise on Ceramic Industries.....	8vo,	6 00
Bowie, A. J., Jr. A Practical Treatise on Hydraulic Mining..	8vo,	5 00
Bowles, O. Tables of Common Rocks.....	16mo,	0 75
Bowser, E. A. Elementary Treatise on Analytic Geometry..	12mo,	1 75
— Elementary Treatise on the Differential and Integral Calculus	12mo,	2 25
Bowser, E. A. Elementary Treatise on Analytic Mechanics, 12mo,		3 00
— Elementary Treatise on Hydro-mechanics.....	12mo,	2 50
— A Treatise on Roofs and Bridges.....	12mo,	*2 25
Boycott, G. W. M. Compressed Air Work and Diving....	8vo,	*4 25
Bradford, G. Whys and Wherefores of Navigation..	12mo,	2 00
— Sea Terms and Phrases.....	12mo, fabrikoid (<i>In Press.</i>)	
Bragg, E. M. Design of Marine Engines and Auxiliaries...		4 00
Brainard, F. R. The Sextant.....	16mo,	
Brassey's Naval Annual for 1919.....	8vo,	10 00
Briggs, R., and Wolff, A. R. Steam-Heating.....	16mo,	0 75
Bright, C. The Life Story of Sir Charles Tilson Bright..	8vo,	*4 50
— Telegraphy, Aeronautics and War.....	8vo,	6 00
Brislee, T. J. Introduction to the Study of Fuel....	8vo,	3 50
Broadfoot, S. K. Motors Secondary Batteries.....	12mo,	*0 75
Broughton, H. H. Electric Cranes and Hoists.....		
Brown, G. Healthy Foundations.....	16mo,	0 75
Brown, H. Irrigation.....	8vo,	6 00
Brown, H. Rubber.....	8vo,	*2 50
Brown, W. A. Portland Cement Industry.....	8vo,	3 00
Brown, Wm. N. The Art of Enamelling on Metal....	12mo,	*2 00
— Handbook on Japanning.....	12mo,	*2 00
— House Decorating and Painting.....	12mo,	*2 00
— History of Decorative Art.....	12mo,	*0 50
— Dipping, Burnishing, Lacquering and Bronzing Brass Ware	12mo,	*1 50
— Workshop Wrinkles	8vo,	*1 00

8 D. VAN NOSTRAND COMPANY'S SHORT-TITLE CATALOG

Browne, C. L. Fitting and Erecting of Engines.....	8vo,	*1 50
Browne, R. E. Water Meters.....	16mo,	0 75
Bruce, E. M. Detection of the Common Food Adulterants,	12mo,	1 40
Brunner, R. Manufacture of Lubricants, Shoe Polishes and Leather Dressings	8vo,	*3 50
Buel, R. H. Safety Valves.....	16mo,	0 75
Bunkley, J. W. Military and Naval Recognition Book..	12mo,	1 00
Burley, G. W. Lathes, Their Construction and Operation,	12mo,	2 00
— Machine and Fitting Shop Practice 2 vols..	12mo, each,	2 00
— Testing of Machine Tools.....	12mo,	2 00
Burnside, W. Bridge Foundations.....	12mo,	*2 00
Burstall, F. W. Energy Diagram for Gas. With text..	8vo,	1 50
— Diagram sold separately.....		*1 00
Burt, W. A. Key to the Solar Compass.....	16mo, leather,	2 50
Buskett, E. W. Fire Assaying.....	12mo,	*1 25
Butler, H. J. Motor Bodies and Chasis.....	8vo,	*3 00
Byers, H. G., and Knight, H. G. Notes on Qualitative Analysis.....	(New Edition in Preparation.)	
Cain, W. Brief Course in the Calculus.....	12mo,	*1 75
— Elastic Arches	16mo,	0 75
— Maximum Stresses	16mo,	0 75
— Practical Designing Retaining of Walls.....	16mo,	0 75
— Theory of Steel-concrete Arches and of Vaulted Struc- tures	16mo,	0 75
— Theory of Voussoir Arches.....	16mo,	0 75
— Symbolic Algebra	16mo,	0 75
Calvert, G. T. The Manufacture of Sulphate of Ammonia and Crude Ammonia	12mo,	4 00
Carey, A. E., and Oliver, F. W. Tidal Lands.....	8vo,	5 00
Carhart, H. S. Thermo-Electromotive Force in Electric Cells	12mo (In Press.)	
Carpenter, F. D. Geographical Surveying.....	16mo,	
Carpenter, R. C., and Diederichs, H. Internal-Combustion Engines	8vo,	5 50
Carpmael, H. Electric Welding and Welding Appliances.	4to,	5 00
Carter, H. A. Ramie (Rhea), China Grass.....	12mo,	*3 00

Carter, H. R. Modern Flax, Hemp, and Jute Spinning.....	8vo,	*3 50
— Bleaching, Dyeing and Finishing of Fabrics.....	8vo,	*1 25
Cary, E. R. Solution of Railroad Problems With the Use of the Slide Rule.....	16mo,	1 25
Casler, M. D. Simplified Reinforced Concrete Mathematics,	12mo,	1 25
Cathcart, W. L. Machine Design. Part I. Fastenings... ..	8vo,	*3 00
Cathcart, W. L., and Chaffee, J. I. Elements of Graphic Statics	8vo,	*3 00
— Short Course in Graphics.....	12mo,	1 50
Caven, R. M., and Lander, G. D. Systematic Inorganic Chem- istry	12mo,	2 25
Chalkley, A. P. Diesel Engines.....	8vo,	5 00
Chalmers, T. W. The Production and Treatment of Veg- etable Oils.....	4to,	7 50
— Paper Making and Its Machinery.....	4to,	8 00
— The Gyroscopic Compass.....	8vo,	5 00
Chamber's Mathematical Tables.....	8vo,	2 50
Chambers, G. F. Astronomy.....	16mo,	*1 50
Chappel, E. Five Figure Mathematical Tables.....	8vo,	2 50
Charnock. Mechanical Technology.....	8vo,	*3 50
Charpentier, P. Timber.....	8vo,	*6 00
Chatley, H. Principles and Designs of Aeroplanes.....	16mo,	0 75
— How to Use Water Power.....	12mo,	*1 50
— Gyrostatic Balancing	8vo,	*1 25
Child, C. D. Electric Arc.....	8vo,	*2 00
Christian, M. Disinfection and Disinfectants.....	12mo,	2 50
Christie, W. W. Boiler-waters, Scale, Corrosion, Foaming,	8vo,	*3 00
— Chimney Design and Theory.....	8vo,	*3 00
— Furnace Draft	16mo,	0 75
— Water, Its Purification and Use in Industries....	8vo,	3 00
Cisin, H. J. Modern Marine Engineering. 12mo, fabrikoid (<i>In Press</i>)		
Church's Laboratory Guide.....	8vo,	2 50
Clapham, J. H. Woolen and Worsted Industries.....	8vo,	2 00
Clapperton, G. Practical Papermaking.....	8vo, (<i>Reprinting.</i>)	
Clark, A. G. Motor Car Engineering. Vol. I. Construction.....		*4 00
Vol. II. Design.....		3 50
Clark, C. H. Marine Gas Engines. New Edition.....		2 00

10 D. VAN NOSTRAND COMPANY'S SHORT-TITLE CATALOG

Clark, J. W., and Scott, W. Plumbing Practice.		
Vol. I Lead Working and Plumbers' Materials..8vo,		*4 00
Vol. II Sanitary Plumbing and Fittings.....(In Press.)		
Vol. III Practical Lead Working on Roofs.....(In Press.)		
Clarkson, R. P. Elementary Electrical Engineering.....(In Press.)		
Clerk, D., and Idell, F. E. Theory of the Gas Engine.	16mo,	0 75
Clevenger, S. R. Treatise on the Method of Government		
Surveying	16mo, mor.,	2 50
Clouth, F. Rubber, Gutta-Percha, and Balata.....	8vo,	*6 00
Cochran, J. Treatise on Cement Specifications.....	8vo,	*1 00
— Concrete and Reinforced Concrete Specifications...8vo,		*2 50
Cocking, W. C. Calculations of Steel-Frame Structures..12mo,		2 50
Coffin, J. H. C. Navigation and Nautical Astronomy..12mo,		*3 00
Colburn, Z., and Thurston, R. H. Steam Boiler Explosions.	16mo,	0 75
Cole, R. S. Treatise on Photographic Optics.....	12mo,	2 00
Coles-Finch, W. Water, Its Origin and Use.....	8vo,	3 50
Collins, C. D. Drafting Room Methods, Standards and		
Forms.....	8vo,	2 00
Collins, J. E. Useful Alloys and Memoranda for Goldsmiths,		
Jewelers.....	16mo,	0 50
Collins, S. Hoare. Plant Products and Chemical Fertilizers,		
.....	8vo,	3 00
— Chemical Fertilizers and Parasitocides.....		3 50
Collis, A. G. High and Low Tension Switch-Gear Design.8vo,		*3 50
— Switchgear	12mo,	0 50
Colver, E. D. S. High Explosives.....	8vo,	12 50
Comstock, D. F., and Troland, L. T. The Nature of Matter		
and Electricity.....	12mo,	2 50
Coombs, H. A. Gear Teeth.....		0 75
Cooper, W. R. Primary Batteries.....	8vo,	*6 00
Copperthwaite, W. C. Tunnel Shields.....	4to,	*9 00
Corfield, W. H. Dwelling Houses.....	16mo,	0 75
— Water and Water-Supply.....	16mo,	0 75
Cornwall, H. B. Manual of Blow-pipe Analysis.....	8vo,	*2 50
Couch, J. F. Dictionary of Chemical Terms.....	12mo,	3 00
Cowee, G. A. Practical Safety Methods and Devices...8vo,		4 00

Cowell, W. B. Pure Air, Ozone, and Water.....	12mo,	*2 50
Craig, J. W., and Woodward, W. P. Questions and Answers About Electrical Apparatus.....	12mo, leather,	1 50
Craig, T. Motion of a Solid in a Fuel.....	16mo,	0 75
— Wave and Vortex Motion.....	16mo,	0 75
Crehore, A. C. Mystery of Matter and Energy.....	12mo,	1 00
— The Atom.....	12mo,	2 00
Crocker, F. B., and Arendt, M. Electric Motors.....	8vo,	*2 50
— and Wheeler, S. S. The Management of Electrical Machinery	12mo,	*1 00
Crosby, E. U., Fiske, H. A., and Forster, H. W. Handbook of Fire Protection.....	12mo,	4 00
Cross, C. F., Bevan, E. J., and Sindall, R. W. Wood Pulp and Its Uses.....	8vo,	3 50
Crosskey, L. R. Elementary Perspective.....	8vo,	2 50
Crosskey, L. R., and Thaw, J. Advanced Perspective....	8vo,	2 00
Culley, J. L. Theory of Arches.....	16mo,	0 75
Cushing, H. C., Jr., and Harrison, N. Central Station Man- agement		*2 00
Dadourian, H. M. Analytical Mechanics.....	8vo,	3 75
— Graphic Statics.....	8vo,	0 75
Danby, A. Natural Rock Asphalts and Bitumens.....	8vo,	*2 50
Darling, E. R. Inorganic Chemical Synonyms.....	12mo,	1 00
Davenport, C. The Book.....	8vo,	2 50
Davey, N. The Gas Turbine.....	8vo,	*4 00
Davies, F. H. Electric Power and Traction.....	8vo,	*2 00
— Foundations and Machinery Fixing.....	16mo	*1 00
Deerr, N. Sugar Cane.....	8vo,	10 00
Deite, C. Manual of Toilet Soap-Making.....	8vo,	7 00
De la Coux, H. The Industrial Uses of Water.....	8vo,	*5 00
Del Mar, W. A. Electric Power Conductors.....	8vo,	*2 00
Denny, G. A. Deep-Level Mines of the Rand.....	4to,	*10 00
De Roos, J. D. C. Linkages.....	16mo,	0 75
Derr, W. L. Block Signal Operations.....	Oblong 12mo,	*1 50
Desaint, A. Three Hundred Shades and How to Mix Them. 8vo,		9 00
De Varona, A. Sewer Gases.....	16mo,	0 75
Devey, R. G. Mill and Factory Wiring.....	12mo,	*1 00

12 D. VAN NOSTRAND COMPANY'S SHORT-TITLE CATALOG

Dichman, C. Basic Open-Hearth Steel Process.....	8vo,	4 00
Dieterich, K. Analysis of Resins, Balsams, and Gum Resins.	8vo,	*3 50
Dilworth, E. C. Steel Railway Bridges.....	4to,	6 00
Dinger, Lieut. H. C. Care and Operation of Naval Machinery	12mo,	3 00
Dixon, D. B. Machinist's and Steam Engineer's Practical Calculator	16mo, mor.,	1 25
Dommett, W. E. Motor Car Mechanism.....	12mo,	*2 00
Dorr, B. F. The Surveyor's Guide and Pocket Table-book.	16mo., mor.,	2 00
Draper, C. H. Heat and the Principles of Thermo-dynamics,	12mo,	2 25
Draper, E. G. Navigating the Ship.....	12mo,	2 00
Dubbel, H. High Power Gas Engines.....	8vo,	*5 00
Dumesny, P., and Noyer, J. Wood Products, Distillates, and Extracts	8vo,	*5 00
Duncan, W. G., and Penman, D. The Electrical Equipment of Collieries	8vo,	*5 00
Dunkley, W. G. Design of Machine Elements. 2 vols.	12mo, each,	*2 00
Dunstan, A. E., and Thole, F. B. T. Textbook of Practical Chemistry	12mo,	3 00
Durham, H. W. Saws.....	8vo,	2 50
Duthie, A. L. Decorative Glass Processes.....	8vo,	2 50
Dwight, H. B. Transmission Line Formulas.....	8vo,	2 00
Dyke, A. L. Dyke's Automobile and Gasoline Engine Encyclopedia	8vo,	6 00
Dyson, S. S. and Clarkson, S. S. Chemical Works.....	8vo,	9 00
— A Manual of Chemical Plant. 12 parts.....	4to, paper,	7 50
Eccles, W. H. Wireless Telegraphy and Telephony.....	12mo,	7 00
Eck, J. Light, Radiation and Illumination.....	8vo,	*2 50
Eddy, H. T. Maximum Stresses Under Concentrated Loads,	8vo,	1 50
Edelman, P. Inventions and Patents.....	12mo,	*1 50
Edgecumbe, K. Industrial Electrical Measuring Instruments,	8vo,	5 00
Edler, R. Switches and Switchgear.....	8vo,	*4 00

Eissler, M. The Metallurgy of Gold.....	.8vo,	9 00
— The Metallurgy of Silver.....	.8vo,	4 00
— The Metallurgy of Argentiferous Lead.....	.8vo,	6 25
— A Handbook of Modern Explosives.....	.8vo,	5 00
Ekin, T. C. Water Pipe and Sewage Discharge Diagrams,	folio,	*3 00
Electric Light Carbons, Manufacture of.....	.8vo,	1 00
Eliot, C. W., and Storer, F. H. Compendious Manual of Qualita-		
tive Chemical Analysis.....	12mo,	1 50
Elliott, A. W. M. Rectangular Areas.....	12mo,	3 00
Ellis, C. Hydrogenation of Oils.....	.8vo,	7 50
— Ultraviolet Light, its Application in Chemical Arts,	12mo (In Press.)	
— and Meigs, J. V. Gasolene and Other Motor Fuels.	(In Preparation.)	
Ellis, G. Modern Technical Drawing.....	.8vo,	*2 00
Ennis, Wm D. Linseed Oil and Other Seed Oils.....	.8vo,	5 00
— Applied Thermodynamics.....	.8vo,	5 00
— Flying Machines To-day.....	12mo,	*1 50
— Vapors for Heat Engines.....	12mo,	*1 00
Ermen, W. F. A. Materials Used in Sizing.....	.8vo,	*2 00
Erwin, M. The Universe and the Atom.....	12mo (Reprinting)	
Ewing, A. J. Magnetic Induction in Iron.....	.8vo,	*5 00
Page, A. Airscrews in Theory and Practice.....	4to,	10 00
Fairchild, J. F. Graphical Compass Conversion Chart and		
Tables.....		0 50
Fairie, J. Notes on Lead Ores.....	12mo,	*0 50
— Notes on Pottery Clays.....	12mo,	*2 00
Fairley, W., and Andre, Geo. J. Ventilation of Coal Mines.		
	16mo,	0 75
Fairweather, W C. Foreign and Colonial Patent Laws ..	.8vo,	*3 00
Falk, K. G. Chemical Reactions: Their Theory and Mechanism,		
	12mo,	2 50
Fanning, J. T. Hydraulic and Water-supply Engineering.	.8vo,	*5 00
Farnsworth, P. V. Shop Mathematics.....	12mo (In Press.)	
Fay, I. W. The Coal-tar Dyes.....	.8vo,	5 00
Fernbach, R. L. Glue and Gelatine.....	.8vo,	*3 00
Findlay, A. The Treasures of Coal Tar.....	12mo,	2 00
Firth, J. B. Practical Physical Chemistry.....	12mo,	*1 25

14 D. VAN NOSTRAND COMPANY'S SHORT-TITLE CATALOG

Fischer, E. The Preparation of Organic Compounds.....	12mo,	2 00
Fisher, H. K. C., and Darby, W. C. Submarine Cable Testing.	8vo,	*4 00
Fleischmann, W. The Book of the Dairy.....	8vo,	4 50
Fleming, J. A. The Alternate-current Transformer. Two Volumes.....	8vo,	
Vol. I. The Induction of Electric Currents.....		*6 50
Vol. II. The Utilization of Induced Currents.....		*6 50
Fleming, J. A. Propagation of Electric Currents.....	8vo,	5 00
— A Handbook for the Electrical Laboratory and Testing Room. Two Volumes.....	8vo, each,	*6 50
Fleury, P. Preparation and Uses of White Zinc Paints.....	8vo,	3 00
Flynn, P. J. Flow of Water.....	12mo,	0 75
— Hydraulic Tables	16mo,	0 75
Foster, H. A. Electrical Engineers' Pocket-book. (<i>Seventh Edition.</i>).....	12mo, leather,	5 00
— Engineering Valuation of Public Utilities and Factories,	8vo,	*3 00
Fowle, F. F. Overhead Transmission Line Crossings.....	12mo,	*1 50
— The Solution of Alternating Current Problems.....	8vo (<i>In Press.</i>)	
Fox, W. G. Transition Curves.....		0 75
Fox, W., and Thomas, C. W. Practical Course in Mechanical Drawing.....	12mo,	1 25
Foye, J. C. Chemical Problems.....	16mo,	0 75
— Handbook of Mineralogy.....	16mo,	0 75
Francis, J. B. Lowell Hydraulic Experiments.....	4to,	15 00
Franzen, H. Exercises in Gas Analysis.....	12mo,	*1 00
Fraser, E. S., and Jones, R. B. Motor Vehicles and Their Engines	8vo, fabrikoid,	2 00
Freudemacher, P. W. Electrical Mining Installations.....	12mo,	*1 00
Friend, J. N. The Chemistry of Linseed Oil.....	12mo,	1 00
Fritsch, J. Manufacture of Chemical Manures.....	8vo,	*5 00
Frye, A. I. Civil Engineers' Pocket-book.....	12mo, leather,	*5 00
Fuller, G. W. Investigations into the Purification of the Ohio River.....	4to,	*10 00
Furnell, J. Paints, Colors, Oils, and Varnishes.....	8vo,	

D. VAN NOSTRAND COMPANY'S SHORT-TITLE CATALOG 15

Gant, L. W. Elements of Electric Traction.....	8vo,	*2 50
Garcia, A. J. R. V. Spanish-English Railway Terms.....	8vo,	3 00
Gardner, H. A. Paint Researches and Their Practical Application	8vo,	*5 00
Garforth, W. E. Rules for Recovering Coal Mines after Explosions and Fires.....	12mo, leather,	1 50
Garrard, C. C. Electric Switch and Controlling Gear....	8vo,	*6 00
Gaudard, J. Foundations.....	16mo,	0 75
Gear, H. B., and Williams, P. F. Electric Central Station Distributing Systems	8vo,	3 50
Geerligs, H. C. P. Cane Sugar and Its Manufacture....	8vo,	*6 00
— Chemical Control in Cane Sugar Factories.....	4to,	5 00
Geikie, J. Structural and Field Geology.....	8vo,	7 50
— Mountains, Their Origin, Growth and Decay.....	8vo,	4 50
— The Antiquity of Man in Europe.....	8vo,	*3 00
Georgi, F., and Schubert, A. Sheet Metal Working....	8vo,	3 50
Gerhard, W. P. Sanitation, Water-supply and Sewage Disposal of Country Houses.....	12mo,	2 50
— Gas Lighting	16mo,	0 75
— House Drainage	16mo,	0 75
— Household Wastes	16mo,	0 75
— Sanitary Drainage of Buildings.....	16mo,	0 75
Gerhardi, C. W. H. Electricity Meters.....	8vo,	*7 20
Geschwind, L. Manufacture of Alum and Sulphates....	8vo,	*5 00
Gibbings, A. H. Oil Fuel Equipment for Locomotives.....	8vo,	
	(Reprinting)	
Gibbs, W. E. Lighting by Acetylene.....	12mo,	*1 50
Gibson, A. H. Hydraulics and Its Application.....	8vo,	*6 00
— Water Hammer in Hydraulic Pipe Lines.....	12mo,	2 50
Gibson, A. H., and Ritchie, E. G. Circular Arc Bow Girder.	4to,	*3 50
Gilbreth, F. B. Motion Study.....	12mo,	*2 00
— Primer of Scientific Management.....	12mo,	*1 00
Gillmore, Gen. Q. A. Roads, Streets, and Pavements....	12mo,	1 25
Godfrey, E. Tables for Structural Engineers....	16mo, leather,	*2 50
Golding, H. A. The Theta-Phi Diagram.....	12mo,	*2 00
Goldschmidt, R. Alternating Current Commutator Motor.	8vo,	*3 00
Goodchild, W. Precious Stones.....	8vo,	2 50

Goodell, J. M. The Location, Construction and Maintenance of Roads	8vo,	2 00
Goodeve, T. M. Textbook on the Steam-engine	12mo,	2 50
Gore, G. Electrolytic Separation of Metals	8vo,	4 50
Gould, E. S. Arithmetic of the Steam-engine	12mo,	1 00
— Calculus	16mo,	0 75
— High Masonry Dams	16mo,	0 75
— Practical Hydrostatics and Hydrostatic Formulas	16mo,	0 75
Goulding, E. Cotton and Other Vegetable Fibres	8vo,	3 00
Gratacap, L. P. A Popular Guide to Minerals	8vo,	*2 00
Gray, H. H. Gas-Works Products	8vo (In Press.)	
Gray, J. Electrical Influence Machines	12mo,	2 00
Gray, J. Marine Boiler Design	12mo, (Reprinting.)	
Greenhill, G. Dynamics of Mechanical Flight	8vo,	*2 50
Greenwood, H. C. The Industrial Gases	8vo,	5 00
Gregorious, R. Mineral Waxes	12mo,	*3 00
Grierson, R. Modern Methods of Ventilation	8vo,	3 00
Griffiths, A. B. A Treatise on Manures	12mo, (Reprinting.)	
Gross, E. Hops	8vo,	*5 00
Grossman, J. Ammonia and its Compounds	12mo,	1 50
Groth, L. A. Welding and Cutting Metals by Gases or Electricity	8vo,	3 00
Grover, F. Modern Gas and Oil Engines	8vo,	*3 00
Gruner, A. Power-loom Weaving	8vo,	*3 50
Grunsky, C. E. Topographic Stadia Surveying	12mo,	2 00
Gunther, C. O. Integration	8vo,	1 50
Gurden, R. L. Traverse Tables	folio, half mor.,	*7 50
Guy, A. E. Experiments on the Flexure of Beams	8vo,	*1 25
Haenig, A. Emery and the Emery Industry	8vo,	*2 50
Hainbach, R. Pottery Decoration	12mo,	*3 50
Hale, A. J. The Manufacture of Chemicals by Electrolysis,	8vo,	2 00
Hale, Harrison. American Chemistry	12mo, (In Press.)	
Hale, W. J. Calculations of General Chemistry	12mo,	1 50
Hall, C. H. Chemistry of Paints and Paint Vehicles	12mo,	*2 00
Hall, R. H. Governors and Governing Mechanism	12mo,	*2 50

Hall, W. S. Elements of the Differential and Integral Calculus	8vo,	2 75
— Descriptive Geometry.....	8vo volume and 4to atlas,	4 00
Haller, G. F., and Cunningham, E. T. The Tesla Coil.....	12mo,	*1 25
Halsey, F. A Slide Valve Gears.....	12mo,	1 50
— The Use of the Slide Rule.....	16mo,	0 75
— Worm and Spiral Gearing.....	16mo,	0 75
Hamlin, M. L. Action of Chemicals on Industrial Materials,	12mo, (<i>In Press.</i>)	
Hancock, H. Textbook of Mechanics and Hydrostatics....	8vo,	1 50
Hardy, E. Elementary Principles of Graphic Statics....	12mo,	*1 50
Haring, H. Engineering Law.		
Vol. I. Law of Contract.....	8vo,	*4 00
Harper, J. H. Hydraulic Tables on the Flow of Water.	16mo,	*2 00
Harris, S. M. Practical Topographical Surveying.....	(<i>In Press.</i>)	
Harrow, B. Eminent Chemists of Our Times: Their Lives		
and Work	(<i>In Press.</i>)	
— From Newton to Einstein.....	12mo,	1 00
Harvey, A. Practical Leather Chemistry.....	8vo,	6 00
Haskins, C. H. The Galvanometer and Its Uses.....	16mo,	1 50
Hatt, J. A. H. The Colorist.....	square 12mo,	*1 50
Hausbrand, E. Drying by Means of Air and Steam.	12mo,	*2 50
— Evaporating, Condensing and Cooling Apparatus.	8vo,	*6 00
Hausmann, E. Telegraph Engineering.....	8vo,	*3 00
Hausner, A. Manufacture of Preserved Foods and Sweetmeats.		
	8vo,	*3 50
Hawkesworth, J. Graphical Handbook for Reinforced Concrete		
Design	4to,	*2 00
Hay, A. Continuous Current Engineering.....	8vo,	3 75
Hayes, H. V. Public Utilities, Their Cost New and Deprecia-		
tion.....	8vo,	*2 00
— Public Utilities, Their Fair Present Value and Return,		
	8vo,	*2 00
Heath, F. H. Chemistry of Photography.....	8vo (<i>In Press.</i>)	
Heather, H. J. S. Electrical Engineering.....	8vo,	*4 50
Heaviside, O. Electromagnetic Theory.		
Vols. I and II.....	8vo, each, (<i>Reprinting.</i>)	
Vol. III.....	8vo, (<i>Reprinting.</i>)	

Heck, R. C. H. Steam Engine and Turbine.....	8vo,	4 50
— Steam-Engine and Other Steam Motors. Two Volumes.		
Vol. I. Thermodynamics and Mechanics.....	8vo,	4 50
Vol. II. Form Construction and Working.....	8vo,	5 50
— Notes on Elementary Kinematics.....	8vo, boards,	*1 00
— Graphics of Machine Forces.....	8vo, boards,	*1 00
Heermann, P. Dyers' Materials.....	12mo,	*3 00
Hellot, Macquer and D'Apligny. Art of Dyeing Wool, Silk and Cotton.....	8vo,	*2 00
Hering, C., and Getmann, F. H. Standard Tables of Electro- chemical Equivalents.....		*2 00
Hering, D. W. Essentials of Physics for College Students.	8vo,	*2 25
Herington, C. F. Powdered Coal as a Fuel.....	8vo,	3 00
Hermann, G. The Graphical Statics of Mechanism.....	12mo,	2 00
Herzfeld, J. Testing of Yarns and Textile Fabrics.....	8vo,	
	<i>(New Edition in Preparation.)</i>	
Hildenbrand, B. W. Cable-Making.....	16mo,	0 75
Hilditch, T. P. Concise History of Chemistry.....	12mo,	*1 50
Hill, C. W. Laboratory Manual and Notes in Beginning Chemistry.....		<i>(In Press.)</i>
Hill, M. J. M. The Theory of Proportion.....	8vo,	*2 50
Hillhouse, P. A. Ship Stability and Trim.....	8vo,	5 00
Hiroi, I. Plate Girder Construction.....	16mo,	0 75
— Statically-Indeterminate Stresses.....	12mo,	2 50
Hirshfeld, C. F. Engineering Thermodynamics.....	16mo,	0 75
Hoar, A. The Submarine Torpedo Boat.....	12mo,	*2 00
Hobart, H. M. Heavy Electrical Engineering.....	8vo,	*4 50
— Design of Static Transformers.....	12mo,	*2 50
— Electricity.....	8vo,	*2 00
— Electric Trains.....	8vo,	<i>(Reprinting.)</i>
— Electric Propulsion of Ships.....	8vo,	*2 50
Hobart, J. F. Hard Soldering, Soft Soldering, and Brazing.	12mo,	1 25
Hobbs, W. R. P. The Arithmetic of Electrical Measurements	12mo,	0 75

Hoff, J. N. Paint and Varnish Facts and Formulas.....	12mo,	2 00
Hole, W. The Distribution of Gas.....	8vo,	*8 50
Hopkins, N. M. Model Engines and Small Boats.....	12mo,	1 25
—The Outlook for Research and Invention.....	12mo,	2 00
Hopkinson, J., Shoolbred, J. N., and Day, R. E. Dynamic Electricity	16mo,	0 75
Horner, J. Practical Ironfounding.....	8vo,	*2 00
—Gear Cutting, in Theory and Practice.....	8vo, (<i>Reprinting.</i>)	
Houghton, C. E. The Elements of Mechanics of Materials,	12mo,	2 50
Houstoun, R. A. Studies in Light Production.....	12mo,	2 00
Hovenden, F. Practical Mathematics for Young Engineers,	12mo,	*1 50
Howe, G. Mathematics for the Practical Man.....	12mo,	1 50
Howorth, J. Repairing and Riveting Glass, China and Earthen- ware	8vo, paper,	*0 50
Hoyt, W. F. Chemistry by Experimentation.....	12mo,	*0 70
Hubbard, E. The Utilization of Wood-waste.....	8vo,	*2 50
Hubner, J. Bleaching and Dyeing of Vegetable and Fibrous Materials	8vo,	7 50
Hudson, O. F. Iron and Steel.....	8vo,	*2 50
Humphreys, A. C. The Business Features of Engineering Practice	8vo,	2 50
Hunter, A. Bridge Work.....	8vo (<i>In Press.</i>)	
Hurst, G. H. Handbook of the Theory of Color.....	8vo,	*3 50
—Dictionary of Chemicals and Raw Products.....	8vo,	*5 00
—Lubricating Oils, Fats and Greases.....	8vo,	*5 00
—Soaps	8vo,	*6 00
Hurst, G. H., and Simmons, W. H. Textile Soaps and Oils,	8vo,	3 50
Hurst, H. E., and Lattey, R. T. Text-book of Physics.....	8vo,	*3 00
— Also published in Three Parts:		
Vol. I. Dynamics and Heat.....		2 50
Vol. II. Sound and Light.....		2 50
Vol. III. Magnetism and Electricity.....		2 50

20 D. VAN NOSTRAND COMPANY'S SHORT-TITLE CATALOG

Hutchinson, R. W., Jr. Long Distance Electric Power Transmission.....	12mo,	*3 00
Hutchinson, R. W., Jr., and Thomas, W. A. Electricity in Mining	(In Press.)	
Hyde, E. W. Skew Arches.....	16mo,	0 75
Hyde, F. S. Solvents, Oils, Gums and Waxes.....	8vo,	*2 00
Induction Coils	16mo,	0 75
Ingham, A. E. Gearing. A practical treatise.....	8vo,	*2 50
Ingle, H. Manual of Agricultural Chemistry.....	8vo,	5 00
Inness, C. H. Problems in Machine Design.....	12mo,	*3 00
— Centrifugal Pumps	12mo,	*3 00
— The Fan	12mo,	*4 00
Jacob, A., and Gould, E. S. On the Designing and Construction of Storage Reservoirs.....	16mo,	0 75
Jacobs, F. B. Cam Design and Manufacture.....	(In Press.)	
James, H. D. Controllers for Electric Motors.....	8vo,	3 00
Jehl, F. Manufacture of Carbons.....	8vo,	5 00
Jennings, A. S. Commercial Paints and Painting... ..	8vo,	2 50
Jeanison, F. H. The Manufacture of Lake Pigments... ..	8vo,	6 00
Jepson, G. Cams and the Principles of their Construction... ..	8vo,	*1 50
— Mechanical Drawing.....	8vo (In Preparation.)	
Jervis-Smith, F. J. Dynamometers.....	8vo,	*4 00
Jockin, W. Arithmetic of the Gold and Silversmith... ..	12mo,	*1 00
Johnson, C. H., and Earle, R. P. Practical Tests for the Electrical Laboratory	(In Press.)	
Johnson, J. H. Arc Lamps and Accessory Apparatus... ..	12mo,	*0 75
Johnson, T. M. Ship Wiring and Fitting.....	12mo,	(Reprinting.)
Johnston, J. F. W., and Cameron, C. Elements of Agricultural Chemistry and Geology.....	12mo,	2 60
Joly, J. Radioactivity and Geology.....	12mo,	(Reprinting.)
Jones, H. C. Electrical Nature of Matter and Radioactivity	12mo,	2 25
— Nature of Solution.....	8vo,	3 75
— New Era in Chemistry.....	12mo,	*2 00
Jones, J. H. Tinplate Industry.....	8vo,	*3 00

D. VAN NOSTRAND COMPANY'S SHORT-TITLE CATALOG 21

Jones, M. W. Testing Raw Materials Used in Paint....	12mo,	*2 50
Jordan, L. C. Practical Railway Spiral.....	12mo, Leather,	*1 50
Jüptner, H. F. V. Siderology: The Science of Iron....	8vo,	*5 00
Kapp, G. Alternate Current Machinery.....	16mo,	0 75
Kapper, F. Overhead Transmission Lines.....	4to,	*4 00
Keim, A. W. Prevention of Dampness in Buildings....	8vo,	*2 50
Keller, S. S., and Knox, W. E. Analytical Geometry and Calculus		2 00
Kemble, W. T., and Underhill, C. R. The Periodic Law and the Hydrogen Spectrum.....	8vo, paper,	*0 50
Kemp, J. F. Handbook of Rocks.....	8vo,	*1 50
Kennedy, A. B. W., and Thurston, R. H. Kinematics of Machinery	16mo,	0 75
Kennedy, A. B. W., Unwin, W. C., and Idell, F. E. Compressed Air	16mo,	0 75
Kennedy, R. Flying Machines; Practice and Design..	12mo,	2 50
— Principles of Aeroplane Construction.....	8vo,	*2 00
Kent, W. Strength of Materials.....	16mo,	0 75
Kershaw, J. B. C. Fuel, Water and Gas Analysis	8vo,	3 50
— Electrometallurgy	8vo,	2 50
— Electro-Thermal Methods of Iron and Steel Production, 8vo,		3 00
— The Use of Low-Grade and Waste Fuels for Power Generation	8vo,	4 00
Kingzett, C. T. Popular Chemical Dictionary.....	8vo,	4 00
Kinzbrunner, C. Continuous Current Armatures	8vo,	1 50
— Testing of Alternating Current Machines.....	8vo,	*2 00
Kinzer, H. and Walter K. Theory and Practice of Damask Weaving	8vo,	4 00
Kirkaldy, A. W., and Evans, A. D. History and Economics of Transport.....	8vo,	*3 00
Kirkbride, J. Engraving for Illustration.....	8vo,	*1 00
Kirschke, A. Gas and Oil Engines.....	12mo,	1 50
Klein, J. F. Design of a High speed Steam-engine	8vo,	*5 00
— Physical Significance of Entropy.	8vo,	*1 50
Klingenberg, G. Large Electric Power Stations.....	4to,	9 00

22 D. VAN NOSTRAND COMPANY'S SHORT-TITLE CATALOG

Knight, R.-Adm. A. M. Modern Seamanship.....	8vo,	*6 50
— Pocket Edition.....	fabrikoid, 12mo,	3 00
Knott, C. G., and Mackay, J. J. Practical Mathematics .	8vo,	2 50
Knox, J. Physico-chemical Calculations.....	12mo,	1 50
— Fixation of Atmospheric Nitrogen.....	12mo,	1 00
Koester, F. Steam-Electric Power Plants.....	4to,	*5 00
— Hydroelectric Developments and Engineering.....	4to,	6 00
Koller, T. The Utilization of Waste Products.....	8vo,	*5 00
— Cosmetics	8vo,	3 50
Koppe, S. W. Glycerine.....	12mo,	*3 50
Kozmin, P. A. Flour Milling.....	8vo,	8 50
Krauch, C. Chemical Reagents.....	8vo,	7 00
Kremann, R. Application of Physico Chemical Theory to Technical Processes and Manufacturing Methods.	8vo,	*3 00
Kretchmar, K. Yarn and Warp Sizing.....	8vo,	*5 00
Laffargue, A. The Attack in Trench Warfare.....	32mo,	0 50
Lallier, E. V. Elementary Manual of the Steam Engine.	12mo,	*2 00
Lambert, T. Lead and its Compounds.....	8vo,	*3 50
— Bone Products and Manures.....	8vo,	*3 50
Lamborn, L. L. Cottonseed Products.....	8vo,	4 00
— Modern Soaps, Candles, and Glycerin.....	8vo,	10 00
Lamprecht, R. Recovery Work After Pit Fires.....	8vo,	*5 00
Lanchester, F. W. Aerial Flight. Two Volumes. 8vo.		
Vol. I. Aerodynamics		*6 00
Vol. II. Aerodnetics		*6 00
— The Flying Machine.....	8vo,	*3 00
— Industrial Engineering: Present and Post-War Outlook,	12mo,	1 00
Lange, K. R. By-Products of Coal-Gas Manufacture..	12mo,	2 50
La Rue, B. F. Swing Bridges.....	16mo,	0 75
Lassar-Cohn, Dr. Modern Scientific Chemistry.....	12mo,	2 25
Latimer, L. H., Field, C. J., and Howell, J. W. Incandescent Electric Lighting	16mo,	0 75

Latta, M. N. Handbook of American Gas-Engineering Practice.	8vo,	*5 00
— American Producer Gas Practice	4to,	*6 00
Laws, B. C. Stability and Equilibrium of Floating Bodies.	8vo,	4 50
Lawson, W. R. British Railways, a Financial and Commercial Survey	8vo,	2 00
Leask, A. R. Refrigerating Machinery	12mo, (<i>Reprinting.</i>)	
Lecky, S. T. S. "Wrinkles" in Practical Navigation	8vo,	*10 00
— Danger Angle	16mo,	2 50
— Pocket Edition	12mo,	5 00
Le Doux, M. Ice-Making Machines	16mo,	0 75
Leeds, C. C. Mechanical Drawing for Trade Schools.	oblong 4to,	2 25
— Mechanical Drawing for High and Vocational Schools,	4to,	*1 50
— Principles of Engineering Drawing	8vo,	2 00
Lefèvre, L. Architectural Pottery	4to,	*7 00
Lehner, S. Ink Manufacture	8vo,	*2 50
Lemstrom, S. Electricity in Agriculture and Horticulture	8vo,	*1 50
Letts, E. A. Fundamental Problems in Chemistry	8vo,	*2 00
Le Van, W. B. Steam-Engine Indicator	16mo,	0 75
Lewes, V. B. Liquid and Gaseous Fuels	8vo,	3 00
— Carbonization of Coal	8vo,	*5 00
Lewis Automatic Machine Rifle; Operation of	16mo,	*0 60
Licks, H. E. Recreations in Mathematics	12mo,	1 50
Lieber, B. F. Lieber's Five Letter Standard Telegraphic Code,		
— English Edition	8vo,	*15 00
— Spanish Edition	8vo,	*15 00
— French Edition	8vo,	*15 00
— Terminal Index	8vo,	*2 50
— Lieber's Appendix	folio,	*15 00
— Handy Tables	4to,	*2 50
— Bankers and Stockbrokers' Code and Merchants and Shippers' Blank Tables	8vo,	*15 00
— 100,000,000 Combination Code	8vo,	*10 00
Livermore, V. P., and Williams, J. How to Become a Competent Motorman	12mo,	*1 00

Livingstone, R. Design and Construction of Commutators,	8vo,	4 50
— Mechanical Design and Construction of Generators.	.8vo,	4 50
Lloyd, S. L. Fertilizer Materials	12mo,	2 00
Lockwood, T. D. Electricity, Magnetism, and Electro-teleg- raphy.....	.8vo,	2 50
— Electrical Measurement and the Galvanometer....	12mo,	0 75
Lodge, O. J. Elementary Mechanics.....	12mo,	1 50
Loewenstein, L. C., and Crissey, C. P. Centrifugal Pumps..		5 00
Lomax, J. W. Cotton Spinning.....	12mo,	1 50
Lord, R. T. Decorative and Fancy Fabrics.....	.8vo,	*3 50
Loring, A. E. A Handbook of the Electromagnetic Telegraph,	16mo,	0 75
Lowy, A. Organic Type Formulas.....		0 10
Lubschez, B. J. Perspective.....	12mo,	2 00
Lucke, C. E. Gas Engine Design..	.8vo,	*3 00
— Power Plants: their Design, Efficiency, and Power Costs. 2 vols.....	(In Preparation.)	
Luckiesh, M. Color and Its Application.....	.8vo,	*3 50
— Light and Shade and Their Applications.....	.8vo,	*3 00
— Visual Illusions.....	(In Preparation.)	
Lunge, G. Coal-tar Ammonia. Three Parts.....	.8vo,	*25 00
— Manufacture of Sulphuric Acid and Alkali. Four Volumes.	8vo,	
Vol. I. Sulphuric Acid. In three parts.....	(Reprinting.)	
Vol. I. Supplement.....	(Reprinting.)	
Vol. II. Salt Cake, Hydrochloric Acid and Leblanc Soda. In two parts.....	(In Press.)	
Vol. III. Ammonia Soda.....	(In Press.)	
Vol. IV. Electrolytic Methods.....	(In Press.)	
— Technical Chemists' Handbook.....	12mo, leather,	*4 00
— Technical Methods of Chemical Analysis. Vol I. In two parts.....	.8vo, (New Edition in Press.)	
Vol. II. In two parts.....	.8vo, (New Edition in Press.)	
Vol. III. In two parts.....	.8vo, (New Edition in Press.)	
The set (3 vols.) complete.....	(In Press.)	
— Technical Gas Analysis.....	.8vo,	*4 50

D. VAN NOSTRAND COMPANY'S SHORT-TITLE CATALOG 25

Luquer, L. M. Minerals in Rock Sections.....	8vo,	*1 50
MacBride, J. D. A Handbook of Practical Shipbuilding,	12mo, fabrikoid	2 00
Macewen, H. A. Food Inspection.....	8vo,	*2 50
Mackenzie, N. F. Notes on Irrigation Works.....	8vo,	*2 50
Mackie, J. How to Make a Woolen Mill Pay.....	8vo,	*2 00
Maguire, Wm. R. Domestic Sanitary Drainage and Plumbing	8vo,	4 00
Malcolm, H. W. Submarine Telegraph Cable.....		9 00
Malinovsky, A. Analysis of Ceramic Materials and Methods of Calculation	(In Press.)	
Mallet, A. Compound Engines.....	16mo,	
Mansfield, A. N. Electro-magnets.....	16mo,	0 75
Marks, E. C. R. Construction of Cranes and Lifting Machinery		
— Manufacture of Iron and Steel Tubes.....	12mo,	*2 75
— Mechanical Engineering Materials.....	12mo,	2 50
Marks, G. C. Hydraulic Power Engineering.....	12mo,	*1 50
Marks, G. C. Hydraulic Power Engineering.....	8vo,	4 50
Marlow, T. G. Drying Machinery and Practice.....	8vo (Reprinting)	
Marsh, C. F. Concise Treatise on Reinforced Concrete....	8vo,	*2 50
— Reinforced Concrete Compression Member Diagram Mounted on Cloth Boards.....		*1 50
Marsh, C. F., and Dunn, W. Manual of Reinforced Concrete and Concrete Block Construction.....	16mo,	2 00
Marshall, W. J., and Sankey, H. R. Gas Engines.....	8vo,	*2 00
Martin, G. Triumphs and Wonders of Modern Chemistry.		
— Modern Chemistry and Its Wonders.....	8vo,	*3 00
Martin, N. Properties and Design of Reinforced Concrete,	8vo,	*3 00
—	8vo,	1 50
Martin, W. D. Hints to Engineers.....	12mo,	2 00
Massie, W. W., and Underhill, C. R. Wireless Telegraphy and Telephony.....	12mo,	*1 00
Mathot, R. E. Internal Combustion Engines.....	8vo,	5 00

26 D. VAN NOSTRAND COMPANY'S SHORT-TITLE CATALOG

Maurice, W. Electric Blasting Apparatus and Explosives ..8vo,	*3 50
— Shot Firer's Guide.....8vo,	*1 50
Maxwell, F. Sulphitation in White Sugar Manufacture.12mo,	4 00
Maxwell, J. C. Matter and Motion.....16mo,	0 75
Maxwell, W. H., and Brown, J. T. Encyclopedia of Municipal and Sanitary Engineering.....4to,	*10 00
Mayer, A. M. Lecture Notes on Physics.....8vo,	2 00
McCracken, E. M., and Sampson, C. H. Course in Pattern Making	(In Press.)
McCullough, E. Practical Surveying.....12mo,	3 00
McCullough, R. S. Mechanical Theory of Heat.....8vo,	3 50
McGibbon, W. C. Indicator Diagrams for Marine Engineers, 8vo,	*3 50
— Marine Engineers' Drawing Book.....oblong 4to,	*2 50
— Marine Engineers' Pocketbook.....12mo, leather,	*4 50
McIntosh, J. G. Technology of Sugar.....8vo,	*6 00
— Industrial Alcohol8vo, *3 50
— Manufacture of Varnishes and Kindred Industries. Three Volumes. 8vo.	
Vol. I. Oil Crushing, Refining and Boiling.....	7 00
Vol. II. Varnish Materials and Oil Varnish Making (Reprinting)	
Vol. III. Spirit Varnishes and Materials.....(Reprinting)	
McKillop, M., and McKillop, D. A. Efficiency Methods. 12mo,	1 50
McKnight, J. D., and Brown, A. W. Marine Multitubular Boilers	*2 50
McMaster, J. B. Bridge and Tunnel Centres.....16mo,	0 75
McMechen, F. L. Tests for Ores, Minerals and Metals.12mo,	1 25
McNair, F. V. Handbook for Naval Officers.....12mo,	4 00
McNair, Jas. B. Citrus By-Products.....(In Press.)	
Meade, A. Modern Gas Works Practice.....8vo,	*8 50
Melick, C. W. Dairy Laboratory Guide.....12mo,	*1 25
"Mentor." Self-Instruction for Students in Gas Supply, 12mo,	2 50
— Advanced Self-Instruction for Students in Gas Supply, 12mo,	2 50
— Self Instruction for Students in Gas Engineering.12mo.	

D. VAN NOSTRAND COMPANY'S SHORT-TITLE CATALOG 27

— Elementary	2 00
— Advanced	2 00
Merivale, J. H. Notes and Formulae for Mining Students, 12mo,	1 00
Merritt, Wm. H. Field Testing for Gold and Silver. 16mo, leather,	2 00
Mertens, Colonel. Tactics and Technique in River Crossings. Translated by Major Walter Krueger.....8vo,	3 00
Mierzinski, S. Waterproofing of Fabrics.....8vo,	*2 50
Miessner, B. F. Radiodynamics.....12mo,	*2 00
Miller, G. A. Determinants.....16mo,	
Miller, W. J. Historical Geology.....12mo,	2 50
Mills, C. N. Elementary Mechanics for Engineers...12mo,	1 25
Milroy, M. E. W. Home Lace-making.....12mo,	*1 00
Mitchell, C. A. Mineral and Aerated Waters.....8vo,	*3 00
— and Prideaux, R. M. Fibres Used in Textile and Allied Industries8vo,	*3 50
Mitchell, C. F. and G. A. Building Construction and Draw- ing. 12mo	
— Elementary Course	2 50
— Advanced Course	4 50
Monckton, C. C. F. Radiotelegraphy.....8vo,	*2 00
Monteverde, R. D. Vest Pocket Glossary of English-Spanish, Spanish-English Technical Terms....64mo, leather,	1 50
Montgomery, J. H. Electric Wiring Specifications...16mo,	*1 00
Moore, E. C. S. New Tables for the Complete Solution of Ganguillet and Kutter's Formula.....8vo,	*6 00
Moore, Harold. Liquid Fuel for Internal Combustion Engines, 8vo,	5 00
Morecroft, J. H., and Hehre, F. W. Short Course in Electrical Testing	8vo, 2 00
Morgan, A. P. Wireless Telegraph Apparatus for Amateurs, 12mo,	*1 50
Morgan, J. D. Principles of Electric Spark Ignition...8vo,	3 50
Morrell, R. S., and Waele, A. E. Rubber, Resins, Paints and Varnishes	8vo (In Press.)
Moses, A. J. The Characters of Crystals.....8vo,	*2 00
— and Parsons, C. L. Elements of Mineralogy.....8vo,	3 50

28 D. VAN NOSTRAND COMPANY'S SHORT-TITLE CATALOG

Moss, S. A. Elements of Gas Engine Design.....	16mo,	0 75
— The Lay-out of Corliss Valve Gears.....	16mo,	0 75
Mulford, A. C. Boundaries and Landmarks.....	12mo,	*1 00
Munby, A. E. Chemistry and Physics of Building Materials.....	8vo,	2 50
Murphy, J. G. Practical Mining.....	16mo,	1 00
Murray, B. M. Chemical Reagents.....	8vo,	3 00
Murray, J. A. Soils and Manures.....	8vo,	*2 00
Nasmith, J. The Student's Cotton Spinning.....	8vo,	4 50
— Recent Cotton Mill Construction.....	12mo,	3 00
Neave, G. B., and Heilbron, I. M. Identification of Organic Compounds	12mo,	1 50
Neilson, R. M. Aeroplane Patents.....	8vo,	*2 00
Nerz, F. Searchlights.....	8vo, (Reprinting.)	
Newbigin, M. I., and Flett, J. S. James Geikie, the Man and the Geologist.....	8vo,	3 50
Newbigin, T. Handbook for Gas Engineers and Managers.....	8vo,	7 50
Newell, F. H., and Drayer, C. E. Engineering as a Career.....	12mo, cloth,	*1 00
Nicol, G. Ship Construction and Calculations.....	8vo,	*10 00
Nipher, F. E. Theory of Magnetic Measurements.....	12mo,	1 00
Nisbet, H. Grammar of Textile Design.....	8vo,	7 50
Nolan, H. The Telescope.....	16mo,	0 75
Norie, J. W. Epitome of Navigation (2 Vols.).....	octavo,	15 00
— A Complete Set of Nautical Tables with Explanations of Their Use.....	octavo,	6 50
North, H. B. Laboratory Experiments in General Chemistry.....	12mo,	*1 00
O'Connor, H. The Gas Engineers' Pocketbook.....	12mo, leather,	5 00
Ohm, G. S., and Lockwood, T. D. Galvanic Circuit.....	16mo,	0 75
Olsen, J. C. Textbook of Quantitative Chemical Analysis.....	8vo,	4 00
Ormsby, M. T. M. Surveying.....	12mo,	2 00
Oudin, M. A. Standard Polyphase Apparatus and Systems.....	8vo,	*3 00
Owen, D. Recent Physical Research.....	8vo,	

Pakes, W. C. C., and Nankivell, A. T. The Science of Hygiene.	8vo,	*1 75
Palaz, A. Industrial Photometry.....	8vo,	*4 00
Palmer, A. R. Electrical Experiments.....	12mo,	0 75
— Magnetic Measurements and Experiments.....	12mo,	0 75
Pamely, C. Colliery Manager's Handbook.....	8vo,	*10 00
Parker, P. A. M. The Control of Water.....	8vo,	*6 00
Parr, G. D. A. Electrical Engineering Measuring Instruments.	8vo,	*3 50
Parry, E. J. Chemistry of Essential Oils and Artificial Per-		
— fumes. Two Volumes.....	8vo.	
Vol. I. Monographs on Essential Oils.....		9 00
Vol. II. Constituents of Essential Oils, Analysis.....		7 00
Parry, E. J. Foods and Drugs. Two Volumes.....	8vo,	
Vol. I. Chemical and Microscopical Analysis of Food		
and Drugs.....		9 50
Vol. II. Sale of Food and Drugs Acts.....		*3 50
— and Coste, J. H. Chemistry of Pigments.....	8vo,	*5 00
Parry, L. Notes on Alloys.....	8vo,	*3 50
— Metalliferous Wastes.....	8vo,	*2 50
— Analysis of Ashes and Alloys.....	8vo,	*2 50
Parry, L. A. Risk and Dangers of Various Occupations.....	8vo,	*3 50
Parshall, H. F., and Hobart, H. M. Electric Railway En-		
— gineering.....	4to,	7 50
Parsons, J. L. Land Drainage.....	8vo,	*1 50
Parsons, S. J. Malleable Cast Iron.....	8vo,	3 50
Partington, J. R. Higher Mathematics for Chemical Students		
— The Alkali Industry.....	12mo,	*2 50
— Textbook of Thermodynamics.....	8vo,	3 00
— Textbook of Thermodynamics.....	8vo,	*4 00
Patchell, W. H. Electric Power in Mines.....	8vo,	*4 00
Paterson, G. W. L. Wiring Calculations.....	12mo,	*2 50
— Electric Mine Signalling Installations.....	12mo,	*1 50
Patterson, D. The Color Printing of Carpet Yarns.....	8vo,	*3 50
— Color Matching on Textiles.....	8vo,	*3 50
— Textile Color Mixing.....	8vo,	*3 50
Paulding, C. P. Condensation of Steam in Covered and Bare		
— Pipes.....	8vo,	*2 00
— Transmission of Heat Through Cold-storage Insulation		
	12mo,	*1 00

30 D. VAN NOSTRAND COMPANY'S SHORT-TITLE CATALOG

Payne, D. W. Founders' Manual.....	8vo,	*4 00-
Peddie, R. A. Engineering and Metallurgical Books....	12mo,	*1 50
Peirce, B. System of Analytic Mechanics.....	4to,	10 00
—Linear Associative Algebra.....	4to,	2 50
Perkin, F. M., and Jagers, E. M. Elementary Chemistry	12mo,	*1 00
Perrin, J. Atoms.....	8vo,	*2 50
Petit, G. White Lead and Zinc White Paints.....	8vo,	*2 00
Petit, R. How to Build an Aeroplane.....	8vo,	*1 50
Pettit, Lieut. J. S. Graphic Processes.....	16mo,	0 75
Philbrick, P. H. Beams and Girders.....	16mo,	
Phin, J. Seven Follies of Sciences.....	12mo,	*1 50
Pickworth, C. N. Logarithms for Beginners....	12mo, boards,	1 00
—The Slide Rule.....	12mo,	1 50
Pilcher, R. B. The Profession of Chemistry.....	12mo,	2 00
Pilcher, R. B., and Butler-Jones, F. What Industry Owes to Chemical Science.....	12mo,	1 50
Plattner's Manual of Blowpipe Analysis. Eighth Edition, re- vised	8vo,	*4 00
Plympton, G. W. The Aneroid Barometer.....	16mo,	0 75
—How to Become an Engineer.....	16mo,	0 75
—Van Nostrand's Table Book.....	16mo,	0 75
Pochet, M. L. Steam Injectors.....	16mo,	0 75
Pocket Logarithms to Four Places.....	16mo,	0 75
	leather,	1 00
Polleyn, F. Dressings and Finishings for Textile Fabrics.	8vo,	*3 50
Pollock, W. Hot Bulb Engines and Suitable Vessels.	8vo,	10 00
Pope, F. G. Organic Chemistry.....	12mo,	3 00
Pope, F. L. Modern Practice of the Electric Telegraph....	8vo,	1 50
Popplewell, W. C. Prevention of Smoke.....	8vo,	*3 50
—Strength of Materials.....	8vo,	*2 50
Porritt, B. D. The Chemistry of Rubber.....	12mo,	*1 00
Porter, J. R. Helicopter Flying Machine.....	12mo,	*1 50
Potts, H. E. Chemistry of the Rubber Industry.....	8vo,	*2 50
Practical Compounding of Oils, Tallow and Grease....	8vo,	*3 50
Pratt, A. E. Economic Metallurgy.....	(In Press.)	
Pratt, Jas. A. Elementary Machine Shop Practice.....	(In Press.)	

Pratt, K. Boiler Draught.....	12mo,	*1 25
Prelini, C. Earth and Rock Excavation.....	8vo,	*3 00
— Graphical Determination of Earth Slopes.....	8vo,	*2 00
— Tunneling.....	8vo,	*3 00
— Dredging. A Practical Treatise.....	8vo,	*3 00
Prescott, A. B., and Johnson, O. C. Qualitative Chemical Analysis	8vo,	4 00
— and Sullivan, E. C. First Book in Qualitative Chemistry	12mo,	*1 50
Prideaux, E. B. R. Problems in Physical Chemistry.....	8vo,	*2 00
— Theory and Use of Indicators.....	8vo,	5 00
Prince, G. T. Flow of Water.....	12mo,	*2 00
Pull, Ernest. Modern Steam Boilers.....	8vo,	5 00
Pullen, W. W. F. Application of Graphic Methods to the Design of Structures.....	12mo,	3 00
— Injectors: Theory, Construction and Working.....	12mo,	*2 00
— Indicator Diagrams.....	8vo,	3 00
— Engine Testing	8vo,	*5 50
Purday, H. F. P. Diesel Engine Design.....	8vo,	7 50
Putsch, A. Gas and Coal-dust Firing.....	8vo,	*2 50
Rafter, G. W. Mechanics of Ventilation.....	16mo,	0 75
— Potable Water	16mo,	0 75
— Treatment of Septic Sewage.....	16mo,	0 75
— and Baker, M. N. Sewage Disposal in the United States	4to,	*6 00
Raikes, H. P. Sewage Disposal Works.....	8vo,	*4 00
Randau, P. Enamels and Enamelling.....	8vo,	*5 00
Rankine, W. J. M. Applied Mechanics.....	8vo,	6 00
— Civil Engineering	8vo,	7 50
— Machinery and Millwork.....	8vo,	6 00
— The Steam-engine and Other Prime Movers.....	8vo,	6 00
— and Bamber, E. F. A Mechanical Textbook.....	8vo,	4 00
Raphael, F. C. Localization of. Faults in Electric Light and Power Mains.....	8vo,	*3 50
Rasch, E. Electric Arc Phenomena.....	8vo,	*2 00
Rathbone, R. L. B. Simple Jewellery.....	8vo,	2 50

32 D. VAN NOSTRAND COMPANY'S SHORT-TITLE CATALOG

Rausenberger, F. The Theory of the Recoil of Guns...	8vo,	*5 00
Rautenstrauch, W. Notes on the Elements of Machine Design,	8vo, boards,	*1 50
Rautenstrauch, W., and Williams, J. T. Machine Drafting and Empirical Design.		
Part I. Machine Drafting.....	8vo,	1 50
Part II. Empirical Design.....	<i>(In Preparation.)</i>	
Raymond, E. B. Alternating Current Engineering.....	12mo,	*2 50
Rayner, H. Silk Throwing and Waste Silk Spinning...	8vo,	
Recipes for the Color, Paint, Varnish, Oil, Soap and Drysaltery Trades	8vo,	*5 00
Recipes for Flint Glass Making.....	12mo,	*5 00
Redfern, J B., and Savin, J. Bells, Telephones.....	16mo,	0 75
Redgrove, H. S. Experimental Mensuration.....	12mo,	*1 50
Reed, S. Turbines Applied to Marine Propulsion.....		*5 00
Reed's Engineers' Handbook.....	8vo,	*9 00
— Key to the Nineteenth Edition of Reed's Engineers' Handbook	8vo,	*4 00
— Useful Hints to Sea-going Engineers.....	12mo,	3 00
Reid, E. E. Introduction to Research in Organic Chemistry.		<i>(In Press.)</i>
Reinhardt, C. W. Lettering for Draftsmen, Engineers, and		
— The Technic of Mechanical Drafting. oblong 4to, boards,		*1 00
Reiser, F. Hardening and Tempering of Steel.....	12mo,	*2 50
Students.....	oblong 4to, boards,	1 25
Reiser, N. Faults in the Manufacture of Woolen Goods. Trans.		
by A. Morris and H. Robson.....	8vo,	*2 50
— Spinning and Weaving Calculations.....	8vo,	*5 00
Renwick, W. G. Marble and Marble Working.....	8vo	<i>(Reprinting)</i>
Reuleaux, F. The Constructor.....	4to,	*4 00
Rey, J. Range of Electric Searchlight Projectors. 8vo, <i>(Reprinting.)</i>		
Reynolds, O., and Idell, F. E. Triple Expansion Engines.		
	16mo,	0 75
Rhead, G. F. Simple Structural Woodwork.....	12mo,	*1 25

Rhead, G. W. British Pottery Marks.....	8vo,	3 50
Rhodes, H. J. Art of Lithography.....	8vo,	5 00
Rice, J. M., and Johnson, W. W. A New Method of Obtaining the Differential of Functions.....	12mo,	0 50
Richards, W. A. Forging of Iron and Steel.....	12mo,	2 25
Richards, W. A., and North, H. B. Manual of Cement Testing, 12mo,		*1 50
Richardson, J. The Modern Steam Engine.....	8vo,	*3 50
Richardson, S. S. Magnetism and Electricity.....	12mo,	*2 00
Rideal, E. K. Industrial Electrometallurgy.....	8vo,	3 00
— The Rare Earths and Metals.....	8vo (In Press.)	
Rideal, S. Glue and Glue Testing.....	8vo,	*5 00
— The Carbohydrates.....	8vo (In Press.)	
Riesenberg, F. The Men on Deck.....	12mo,	3 00
— Standard Seamanship for the Merchant Marine.....	12mo,	
	(In Press.)	
Rimmer, E. J. Boiler Explosions, Collapses and Mishaps.....	8vo,	2 25
Rings, F. Concrete in Theory and Practice.....	12mo,	*4 50
— Reinforced Concrete Bridges.....	4to,	*5 00
Ripper, W. Course of Instruction in Machine Drawing... folio,		*6 00
Roberts, F. C. Figure of the Earth.....	16mo,	0 75
Roberts, J., Jr. Laboratory Work in Electrical Engineering 8vo,		*2 00
Robertson, J. B. The Chemistry of Coal.....	12mo,	1 25
Robertson, L. S. Water-tube Boilers.....	8vo,	2 00
Robinson, J. B. Architectural Composition.....	8vo,	3 50
Robinson, S. W. Practical Treatise on the Teeth of Wheels. 16mo,		0 75
— Railroad Economics	16mo,	0 75
— Wrought Iron Bridge Members.....	16mo,	0 75
Robson, J. H. Machine Drawing and Sketching.....	8vo,	2 00
Roebling, J. A. Long and Short Span Railway Bridges... folio,		25 00
Rogers, A. A Laboratory Guide of Industrial Chemistry.....	8vo,	2 00
— Elements of Industrial Chemistry.....	12mo,	3 00
— Manual of Industrial Chemistry.....	8vo,	7 50
Rogers, F. Magnetism of Iron Vessels.....	16mo,	0 75

Rohland, P. Colloidal and its Crystalloidal State of Matter.	12mo, (<i>Reprinting.</i>)	
Rollinson, C. Alphabets.....	oblong 12mo,	*1 00
Rose, J. The Pattern-makers' Assistant....	8vo,	2 50
— Key to Engines and Engine-running.....	12mo,	2 50
Rose, T. K. The Precious Metals.....	8vo,	2 50
Rosenhain, W. Glass Manufacture.....	8vo,	4 00
— Physical Metallurgy, An Introduction to.....	8vo,	4 00
Roth, W. A. Physical Chemistry.....	8vo,	*2 00
Rowan, F. J. Practical Physics of the Modern Steam-boiler.	8vo,	*3 00
— and Idell, F. E. Boiler Incrustation and Corrosion.	16mo,	0 75
Roxburgh, W. General Foundry Practice.....	8vo,	*2 50
Ruhmer, E. Wireless Telephony.....	8vo,	*4 50
Russell, A. Theory of Electric Cables and Networks.....	8vo,	*3 00
Rust, A. Practical Tables for Navigators and Aviators,	8vo,	3 50
Rutley, F. Elements of Mineralogy.....	12mo,	2 50
Sandeman, E. A. The Manufacture of Earthenware..	12mo,	3 50
Sanford, P. G. Nitro-explosives.....	8vo,	*4 00
Saunders, C. H. Handbook of Practical Mechanics....	16mo,	1 50
	leather,	2 00
Sayers, H. M. Brakes for Tram Cars.....	8vo,	*1 25
Schaefer, C. T. Motor Truck Design.....	8vo,	2 50
Scheele, C. W. Chemical Essays.....	8vo,	*2 50
Scheithauer, W. Shale Oils and Tars.....	8vo,	*4 00
Scherer, R. Casein.....	8vo,	*3 50
Schidrowitz, P. Rubber, Its Production and Industrial Uses,	8vo,	*6 00
Schindler, K. Iron and Steel Construction Works....	12mo,	*2 00
Schmall, C. N. First Course in Analytic Geometry, Plane and		
Solid.....	12mo, half leather,	*1 75
— and Shack, S. M. Elements of Plane Geometry..	12mo,	1 25
Schmeer, L. Flow of Water.....	8vo,	1 50
Schwartz, E. H. L. Causal Geology.....	8vo,	*3 00
Schweizer, V. Distillation of Resins.....	8vo,	*5 00
Scott, A. H. Reinforced Concrete in Practice.....	12mo,	2 00

D. VAN NOSTRAND COMPANY'S SHORT-TITLE CATALOG 35

Scott, W. W. Qualitative Analysis. A Laboratory Manual, New Edition	3 00
— Standard Methods of Chemical Analysis.....	8vo, 7 50
Scribner, J. M. Engineers' and Mechanics' Companion. 16mo, leather,	1 50
Scudder, H. Electrical Conductivity and Ionization Constants of Organic Compounds.....	8vo, *3 00
Seamanship, Lectures on.....	12mo, 2 00
Searle, A. B. Modern Brickmaking.....	8vo, 7 00
— Cement, Concrete and Bricks.....	8vo, 3 00
Searle, G. M. "Summers' Method." Condensed and Improved. 16mo,	0 75
Seaton, A. E. Manual of Marine Engineering.....	8vo, 10 00
Seaton, A. E., and Rounthwaite, H. M. Pocket-book of Marine Engineering	16mo, leather, 6 00
Seeligmann, T., Torrillon, G. L., and Falconnet, H. India Rubber and Gutta Percha.....	8vo, *6 00
Seidell, A. Solubilities of Inorganic and Organic Substances, 8vo,	*7 50
Sellew, W. H. Steel Rails.....	4to, *10 00
— Railway Maintenance Engineering.....	12mo, *3 00
Senter, G. Outlines of Physical Chemistry.....	12mo, 3 00
— Textbook of Inorganic Chemistry.....	12mo, *3 00
Sever, G. F. Electric Engineering Experiments	8vo, boards, *1 00
— and Townsend, F. Laboratory and Factory Tests in Elec- trical Engineering.....	8vo, *2 50
Sewall, C. H. Wireless Telegraphy.....	8vo, *2 00
— Lessons in Telegraphy.....	12mo, *1 00
Sexton, A. H. Fuel and Refractory Materials. 12mo, (<i>Reprinting.</i>)	
— Chemistry of the Materials of Engineering.....	12mo, *3 00
— The Common Metals (Non-Ferrous).....	8vo, 4 00
— Alloys (Non-Ferrous).....	8vo, 3 50
— and Primrose, J. S. G. The Metallurgy of Iron and Steel, 8vo,	*6 50
Seymour, A. Modern Printing Inks.....	8vo, 3 00
Shaw, Henry S. H. Mechanical Integrators.....	16mo, 0 75
Shaw, S. History of the Staffordshire Potteries.....	8vo, 2 50
— Chemistry of Compounds Used in Porcelain Manufacture, 8vo,	*6 00

Shaw, T. R. Driving of Machine Tools.....	12mo,	*2 00
— Precision Grinding Machines.....	12mo,	5 00
Shaw, W. N. Forecasting Weather.....	8vo (<i>Reprinting</i>)	
Sheldon, S., and Hausmann, E. Electric Traction and Transmission Engineering.....	12mo,	3 00
— Dynamo Electric Machinery: Direct and Alternating Cur- rent Machines. Revised and Enlarged Edition.	8vo (<i>In Press.</i>)	
— Physical Laboratory Experiments.....	8vo,	*1 25
Sherriff, F. F. Oil Merchants' Manual and Oil Trade Ready Reckoner.....	8vo,	3 50
Shields, J. E. Note on Engineering Construction.....	12mo,	1 50
Shreve, S. H. Strength of Bridges and Roofs.....	8vo,	3 50
Shunk, W. F. The Field Engineer.....	12mo, fabrikoid,	3 00
Silverman, A., and Harvey, A. W. Laboratory Directions and Study Questions in Inorganic Chemistry,	4to, loose leaf,	2 00
Simmons, W. H. Fats, Waxes and Essential Oils. 8vo (<i>In Press.</i>)		
Simmons, W. H., and Appleton, H. A. Handbook of Soap Manufacture.....	8vo,	*4 00
Simmons, W. H., and Mitchell, C. A. Edible Fats and Oils,	8vo,	*3 50
Simpson, G. The Naval Constructor.....	12mo, fabrikoid,	*5 00
Simpson, W. Foundations.....	8vo (<i>In Press</i>)	
Sindall, R. W. Manufacture of Paper.....	8vo,	3 00
— and Bacon, W. N. The Testing of Wood Pulp....	8vo,	2 50
— Wood and Cellulose.....	8vo (<i>In Press.</i>)	
Sloane, T. O'C. Elementary Electrical Calculations.....	12mo,	2 00
Smallwood, J. C. Mechanical Laboratory Methods,	12mo, fabrikoid,	*3 00
Smith, C. A. M. Handbook of Testing, MATERIALS. 8vo,		*2 50
— and Warren, A. G. New Steam Tables.....	8vo,	*1 25
Smith, C. F. Practical Alternating Currents and Testing. 8vo,		*3 50
— Practical Testing of Dynamos and Motors.....	8vo,	*3 00
Smith, F. E. Handbook of General Instruction for Mechanics.	12mo,	1 50
Smith, G. C. Trinitrotoluenes and Mono- and Dinitroto- luenes, Their Manufacture and Properties.....	12mo,	2 00
Smith, H. G. Minerals and the Microscope.....	12mo,	*2 00
Smith, J. C. Manufacture of Paint.....	8vo,	*5 00

D. VAN NOSTRAND COMPANY'S SHORT-TITLE CATALOG 37

Smith, R. H. Principles of Machine Work.....	12mo,	
—Advanced Machine Work.....	12mo,	*3 00
Smith, W. Chemistry of Hat Manufacturing.....	12mo,	*3 50
Snell, F. D. Calorimetric Analysis.....	12mo,	(In Press.)
Soddy, F. Radioactivity.....	8vo,	(Reprinting.)
Solomon, M. Electric Lamps.....	8vo,	*2 00
Somerscales, A. N. Mechanics for Marine Engineers.....	12mo,	2 50
—Mechanical and Marine Engineering Science.....	8vo,	*5 00
Sothorn, J. W. The Marine Steam Turbine.....	8vo,	*12 50
—Verbal Notes and Sketches for Marine Engineers.....	8vo,	15 00
—Marine Engine Indicator Cards.....	8vo,	4 50
Sothorn, J. W., and Sothorn, R. M. Simple Problems in Marine Engineering Design.....	12mo,	3 00
Souster, E. G. W. Design of Factory and Industrial Build- ings.....	8vo,	4 00
Southcombe, J. E. Chemistry of the Oil Industries.....	8vo,	3 50
Soxhlet, D. H. Dyeing and Staining Marble.....	8vo,	*2 50
Spangenburg, L. Fatigue of Metals.....	16mo,	0 75
Specht, G. J., Hardy, A. S., McMaster, J. B., and Walling. Topo- graphical Surveying.....	16mo,	0 75
Spencer, A. S. Design of Steel-Framed Sheds.....	8vo,	*3 50
Spiegel, L. Chemical Constitution and Physiological Action.	12mo,	*1 25
Sprague, E. H. Elementary Mathematics for Engineers.....	12mo,	2 00
—Elements of Graphic Statics.....	8vo,	2 00
—Hydraulics.....	12mo,	*2 00
—Stability of Arches.....	12mo,	2 00
—Stability of Masonry.....	12mo,	*2 00
—Strength of Structural Elements.....	12mo,	2 00
—Moving Loads by Influence Lines and Other Methods,	12mo,	2 00
Stahl, A. W. Transmission of Power.....	16mo,	
—and Woods, A. T. Elementary Mechanism.....	12mo,	2 25
Standage, H. C. Leatherworkers' Manual.....	8vo,	4 50
—Sealing Waxes, Wafers, and Other Adhesives.....	8vo,	*2 50
—Agglutinants of All Kinds for All Purposes.....	12mo,	*3 50
Stanley, H. Practical Applied Physics.....		(In Press.)
Stansbie, J. H. Iron and Steel.....	8vo,	*2 50

Steadman, F. M. Unit Photography	12mo,	2 50
Stecher, G. E. Cork. Its Origin and Industrial Uses.....	12mo,	1 00
Steinheil, A., and Voit, E. Applied Optics. Vols. I and II, 8vo, each,	8vo, each,	5 00
— Two Volumes	set,	9 00
Steinman, D. B. Suspension Bridges and Cantilevers.....		0 75
— Melan's Steel Arches and Suspension Bridges.....	8vo,	*3 00
Stevens, A. B. Arithmetic of Pharmacy.....	12mo,	1 50
Stevens, E. J. Field Telephones and Telegraphs for Army Use	12mo,	1 20
Stevens, H. P. Paper Mill Chemist.....	16mo,	4 00
Stevens, J. S. Theory of Measurements.....	12mo,	*1 25
Stevenson, J. L. Blast-Furnace Calculations. 12mo, leather.		2 50
Stewart, G. Modern Steam Traps.....	12mo,	*1 75
Stiles, A. Tables for Field Engineers.....	12mo,	1 00
Stodola, A. Steam Turbines.....		*5 00
Stone, E. W. Elements of Radiotelegraphy. 12mo, fabrikoid,		2 50
Stone, H. The Timbers of Commerce.....	8vo,	4 00
Stopes, M. The Study of Plant Life.....	8vo,	2 00
Sudborough, J. J., and James, T. C. Practical Organic Chem- istry	12mo,	3 50
Suffling, E. R. Treatise on the Art of Glass Painting. 8vo,		*3 50
Sullivan, T. V., and Underwood, N. Testing and Valuation Svenson, C. L. Handbook of Piping.....		4 00
of Building and Engineering Materials.....	(In Press.)	
— Essentials of Drafting.....	8vo,	1 75
— Mechanical and Machine Drawing and Design.....	(In Press.)	
Swan, K. Patents, Designs and Trade Marks.....	8vo,	*2 00
Swinburne, J., Wordingham, C. H., and Martin, T. C. Electric Currents	16mo,	0 75
Swoope, C. W. Lessons in Practical Electricity.....	12mo,	*2 00
Tailfer, L. Bleaching Linen and Cotton Yarn and Fabrics. 8vo,		*7 00
Tate, J. S. Surcharged and Different Forms of Retaining- walls	16mo,	0 75
Taylor, F. N. Small Water Supplies.....	12mo,	*2 50
— Masonry in Civil Engineering.....	8vo,	*2 50
Taylor, H. S. Fuel Production and Utilization.....	8vo,	4 00
Taylor, W. Economic Fuel Production.....	(In Press.)	

Taylor, W. T. Electric Power Conductors and Cables. 8vo, (<i>In Press.</i>)	
— Calculation of Electric Conductors..... 4to,	3 00
Templeton, W. Practical Mechanic's Workshop Companion,	
12mo, morocco,	2 00
Tenney, E. H. Test Methods for Steam Power Plants.	
12mo,	*3 00
Terry, H. L. India Rubber and Its Manufacture.. 8vo, (<i>Reprinting.</i>)	
Thayer, H. R. Structural Design..... 8vo,	
Vol. I. Elements of Structural Design.....	2 50
Vol. II. Design of Simple Structures.....	4 50
Vol. III. Design of Advanced Structures..... (<i>In Preparation.</i>)	
— Foundations and Masonry..... (<i>In Preparation.</i>)	
Thiess, J. B., and Joy, G. A. Toll Telephone Practice.. 8vo,	*3 50
Thom, C., and Jones, W. H. Telegraphic Connections,	
oblong 12mo,	1 50
Thomas, C. W. Paper-makers' Handbook..... (<i>In Press.</i>)	
Thomas, J. B. Strength of Ships..... 8vo,	2 50
Thomas, Robt. G. Applied Calculus..... 12mo,	3 00
Thompson, A. B. Oil Fields of Russia..... 4to,	*10 00
— Oil Field Development and Petroleum Mining... 8vo,	15 00
Thompson, S. P. Dynamo Electric Machines..... 16mo,	0 75
Thompson, W. P. Handbook of Patent Law of All Countries,	
16mo,	1 50
Thomson, G. S. Milk and Cream Testing..... 12mo,	*2 25
— Modern Sanitary Engineering, House Drainage, etc. 8vo,	*3 00
Thornley, T. Cotton Combing Machines..... 8vo,	*3 50
— Cotton Waste	8vo, *3 50
— Cotton Spinning	8vo,
First Year	*1 50
Second Year	*3 50
Third Year	*2 50
Thurso, J. W. Modern Turbine Practice..... 8vo,	*4 00
Tidy, C. Meymott. Treatment of Sewage..... 16mo,	0 75
Tillmans, J. Water Purification and Sewage Disposal. 8vo,	2 50
Tinkler, C. K., and Master, H. Applied Chemistry. 8vo, (<i>In Press</i>)	
Tinney, W. H. Gold-mining Machinery..... 8vo,	*3 00
Titherley, A. W. Laboratory Course of Organic Chemistry 8vo,	2 50
Tizard, H. T. Indicators..... (<i>In Press.</i>)	
Toch, M. Chemistry and Technology of Paints..... 8vo,	*4 50
— Materials for Permanent Painting..... 12mo,	2 50

Tod, J., and McGibbon, W. C. Marine Engineers' Board of Trade Examinations	8vo,	*2 00
Todd, J., and Whall, W. B. Practical Seamanship....	8vo,	12 00
Townsend, F. Alternating Current Engineering.....	8vo, boards,	*0 75
Townsend, J. Ionization of Gases by Collision.....	8vo,	*1 25
Transactions of the American Institute of Chemical Engineers. Eleven volumes now ready. Vols. I to XI, 1908-1918, 8vo, each,		*6 00
Traverse Tables	16mo,	0 75
Treiber, E. Foundry Machinery.....	12mo,	*2 00
Trinks, W. Governors and Governing of Prime Movers.....	8vo,	3 50
Trinks, W., and Housum, C. Shaft Governors.....	16mo,	0 75
Trowbridge, W. P. Turbine Wheels.....	16mo,	0 75
Tucker, J. H. A Manual of Sugar Analysis.....	8vo,	3 50
Turnbull, Jr., J., and Robinson, S. W. A Treatise on the Compound Steam-engine	16mo,	0 75
Turner, H. Worsted Spinners' Handbook.....	12mo,	*3 00
Turrill, S. M. Elementary Course in Perspective.....	12mo,	*1 25
Twyford, H. B. Purchasing.....	8vo,	4 00
— Storing, Its Economic Aspects and Proper Methods.....	8vo,	3 50
Underhill, C. R. Solenoids, Electromagnets and Electromag- netic Windings	12mo,	*3 00
Underwood, N., and Sullivan, T. V. Chemistry and Tech- nology of Printing Inks.....	8vo,	4 00
Urquhart, J. W. Electro-plating.....	12mo,	3 00
— Electrotyping	12mo,	2 00
Usborne, P. O. G. Design of Simple Steel Bridges.....	8vo,	*4 00
Vacher, F. Food Inspector's Handbook.....	12mo,	
Van Nostrand's Chemical Annual. Fourth Issue, 1918, fabrikoid, 12mo,		*3 00
— Year Book of Mechanical Engineering Data.....	(In Press.)	
Van Wagenen, T. F. Manual of Hydraulic Mining.....	16mo,	1 00
Vega, Baron, Von. Logarithmic Tables.....	8vo,	2 50
Vincent, C. Ammonia and Its Compounds.....	8vo,	*2 50
Virgin, R. Z. Coal Mine Management.....	(In Press.)	

Volk, C. Haulage and Winding Appliances.....	8vo,	*4 00
Von Georgievics, G. Chemical Technology of Textile Fibres.	8vo,	7 00
—Chemistry of Dyestuffs. 8vo. (<i>New Edition in Preparation.</i>)		
Vose, G. L. Graphic Method for Solving Certain Questions in Arithmetic and Algebra.....	16mo,	0 75
Vosmaer, A. Ozone.....	8vo,	*2 50
Wabner, R. Ventilation in Mines.....	8vo,	*5 00
Wadmore, J. M. Elementary Chemical Theory.....	12mo,	*1 50
Wagner, E. Preserving Fruits, Vegetables, and Meat.....	12mo,	*2 50
Wagner, H. E., and Edwards, H. W. Railway Engineering Estimates	(<i>In Press.</i>)	
Wagner, J. B. Seasoning of Wood.....	8vo,	4 00
Waldram, P. J. Principles of Structural Mechanics.....	12mo,	4 00
Walker, F. Dynamo Building.....	16mo,	0 75
Walker, J. Organic Chemistry for Students of Medicine.....	8vo,	4 00
Walker, S. F. Refrigeration, Heating and Ventilation on Shipboard	12mo,	2 50
— Electricity in Mining.....	8vo,	*4 50
— Electric Wiring and Fitting.....	8vo,	2 50
Wallis-Taylor, A. J. Bearings and Lubrication.....	8vo,	*1 50
— Aerial or Wire Ropeways.....	8vo,	5 00
— Preservation of Wood.....	8vo,	4 00
— Refrigeration, Cold Storage and Ice Making.....	8vo,	5 50
— Sugar Machinery.....	12mo,	3 00
Walsh, J. J. Chemistry and Physics of Mining and Mine Ventilation	12mo,	2 50
Wanklyn, J. A. Water Analysis.....	12mo,	2 00
Wansbrough, W. D. The A B C of the Differential Calculus,	12mo,	*2 50
— Slide Valves	12mo,	*2 00
Waring, Jr., G. E. Sanitary Conditions.....	16mo,	0 75
— Sewerage and Land Drainage.....		*6 00
— Modern Methods of Sewage Disposal.....	12mo,	2 00
— How to Drain a House.....	12mo,	1 25
Warnes, A. R. Coal Tar Distillation.....	8vo,	*5 00
Warren, F. D. Handbook on Reinforced Concrete.....	12mo,	*2 50
Watkins, A. Photography.....	8vo,	3 00

42 D. VAN NOSTRAND COMPANY'S SHORT-TITLE CATALOG

↗	Watson, E. P. Small Engines and Boilers.....	12mo,	1 25
	Watt, A. Electro-plating and Electro-refining of Metals.....	8vo,	5 00
↗	— Electro-plating	12mo,	2 00
	— Electro-metallurgy	12mo,	1 00
	— The Art of Soap-making.....	8vo,	4 00
	— Leather Manufacture	8vo,	6 00
	— Paper Making	8vo,	3 75
	Webb, H. L. Guide to the Testing of Insulated Wires and Cables	12mo,	1 00
	Wegmann, E. Conveyance and Distribution of Water for Water Supply.....	8vo,	5 00
	Weisbach, J. A Manual of Theoretical Mechanics.....	8vo,	*6 00
	— and Herrmann, G. Mechanics of Air Machinery....	8vo,	*3 75
	Wells, Robt. Ornamental Confectionery.....	12mo,	3 00
	Weston, E. B. Loss of Head Due to Friction of Water in Pipes,	12mo,	2 00
	Wheatley, O. Ornamental Cement Work.....	8vo,	*2 25
	Whipple, S. An Elementary and Practical Treatise on Bridge Building	8vo,	3 00
	White, C. H. Methods in Metallurgical Analysis....	12mo,	3 00
	White, G. F. Qualitative Chemical Analysis.....	12mo,	1 40
	White, G. T. Toothed Gearing.....	12mo,	*2 00
	White, H. J. Oil Tank Steamers.....	12mo,	3 00
	Whitelaw, John. Surveying.....	8vo,	4 50
	Whittaker, C. M. Application of the Coal Tar Dyestuffs.....	8vo,	3 00
	Widmer, E. J. Observation Balloons.....	12mo,	3 00
	Wilcox, R. M. Cantilever Bridges.....	16mo,	0 75
	Wilda, H. Steam Turbines.....	12mo,	*2 00
	— Cranes and Hoists	12mo,	*2 00
	Wilkinson, H. D. Submarine Cable Laying and Repairing,	8vo (Reprinting)	
	Williamson, J. Surveying.....	8vo,	*3 00
	Williamson, R. S. Practical Tables in Meteorology and Hypsometry	4to,	2 50
	Wilson, F. J., and Heilbron, I. M. Chemical Theory and Cal- culations	12mo,	1 75
	Wilson, J. F. Essentials of Electrical Engineering.....	8vo,	2 50
	Wimperis, H. E. Internal Combustion Engine.....	8vo,	3 50
	— Application of Power to Road Transport.....	12mo,	*1 50
	— Primer of Internal Combustion Engine.....	12mo,	*1 50

D. VAN NOSTRAND COMPANY'S SHORT-TITLE CATALOG 43

Winchell, N. H., and A. N. Elements of Optical Mineralogy 8vo,	*3 50
Winslow, A. Stadia Surveying.....16mo,	0 75
Wisser, Lieut. J. P. Explosive Materials.....16mo,	
— Modern Gun Cotton.....16mo,	0 75
Wolff, C. E. Modern Locomotive Practice.....8vo,	*4 20
Wood, De V. Luminiferous Aether.....16mo,	0 75
Wood, J. K. Chemistry of Dyeing.....12mo,	*1 00
Worden, E. C. The Nitrocellulose Industry. Two vols. 8vo,	*10 00
— Technology of Cellulose Esters. In 10 vols.....8vo.	
Vol. VIII. Cellulose Acetate.....	*5 00
Wren, H. Organometallic Compounds of Zinc and Magnesium.	
12mo,	*1 00
— Simple Method for Testing Painter's Materials...8vo,	*2 50
Wright, A. C. Simple Method for Testing Painters' Materials	8vo, 2 50
Wright, F. W. Design of a Condensing Plant..12mo, (<i>Reprinting.</i>)	
Wright, J. Testing, Fault Finding, etc., for Wiremen..16mo,	*0 50
Wright, T. W. Elements of Mechanics.....8vo,	*2 50
— and Hayford, J. F. Adjustment of Observations....8vo,	*3 00
Wynne, W. E., and Spraragen, W. Handbook of Engineering Mathematics	12mo, leather, *2 00
Yoder, J. H. and Wharen, G. B. Locomotive Valves and Valve Gears.....8vo,	3 00
Young, J. E. Electrical Testing for Telegraph Engineers...8vo,	*4 00
Young, R. B. The Banket.....8vo,	3 50
Youngson, P. Slide Valve and Valve Gearing.....4to,	3 00
Zahner, R. Transmission of Power.....16mo,	
Zeuner, A. Technical Thermodynamics. Two Volumes..8vo,	*8 00
Zimmer, G. F. Mechanical Handling and Storing of Materials,	
4to,	15 00
— Mechanical Handling of Material and Its National Importance During and After the War.....4to,	4 00
Zipser, J. Textile Raw Materials.....8vo,	*5 00
Zur Nedden, F. Engineering Workshop Machines and Processes	8vo, *2 00

D. VAN NOSTRAND COMPANY

are prepared to supply, either from
their complete stock or at
short notice,

Any Technical or Scientific Book

In addition to publishing a very large and varied number of SCIENTIFIC AND ENGINEERING BOOKS, D. Van Nostrand Company have on hand the largest assortment in the United States of such books issued by American and foreign publishers.

All inquiries are cheerfully and carefully answered and complete catalogs sent free on request.

8 WARREN STREET - - - NEW YORK

5M-Oct. 1920.

APR 29 1921



•••

UNIVERSITY OF MICHIGAN



3 9015 06357 9887

67

